



Communications Products Division

***Direct Access Test Unit Remote Terminal
(DATU-RT)
Model 24820-003***

No part of this publication may be reproduced, stored on a retrieval system, or transmitted, in any form or by any means electronic, mechanical, photocopying, recording, or otherwise, without the prior written permission of Harris Corporation. The use of trademarks or other designations is for reference purposes only.

NOTICE

Harris Corporation makes no warranties about this document. Harris Corporation reserves the right to make hardware and software changes to the product described within this document without prior notice and without obligation to notify any person of such revision or change.

TRADEMARKS

AXE-10 is a trademark of Ericsson North America Incorporated.

DCO is a trademark of Stromberg-Carlson Corporation.

DMS-1, DMS-10, and DMS-100 are trademarks of Nortel Networks Incorporated.

EWSD is a trademark of Siemens Incorporated.

GTD-5 is a trademark of AG Communications Systems.

MFT is a trademark of Western Electric Company.

NEAX-61 is a trademark of NEC America Incorporated.

1A ESS, 2B ESS, 3B ESS, 5 ESS, 1 Crossbar, 5 Crossbar, PGTC, SLC-96, and SLC-Series 5 are trademarks of Lucent Technologies.



next level solutions

Communications Products Division | 809 Calle Plano | Camarillo, CA 93012-8519 USA

www.harris.com 1-800-437-2266

©1996 Harris Corporation
Written/Printed in USA. 0II-724820-003, Issue 8, November 1999

Contents

1.	Overview	1-1
	■ Description	1-2
	■ User Options	1-4
	■ System Features	1-5
2.	Installation	2-1
	■ Considerations for Installation	2-2
	■ Installation Procedures	2-6
3.	Programming System Functions	3-1
	■ Programming Procedures	3-5
	■ Split Pair Gain Systems Overview	3-13
	■ Time Outs and Disconnects	3-27
4.	Selecting Line Preparation Functions	4-1
	■ Description	4-4
	■ Normal (Separate) Line Access—Local Metallic Loops	4-4
	■ Menu Item Selection	4-7
	■ Single-Line Access—Local Metallic Loops	4-13
	■ Normal (Separate) Line Access—Carrier System Lines	4-18
	■ Single-Line Access—Carrier System Lines	4-28
	■ Setting the Hold Time	4-34

5.	Troubleshooting Guide	5-1
	■ Initial LED and Voltage Checks (Step 1)	5-2
	■ Calling the DATU Checks (Step 2)	5-2
	■ Calling the Subscriber Line Checks (Check 3)	5-3
	■ Cut Through Checks (Step 4)	5-4
	■ Disconnect Checks (Step 5)	5-4
	■ Fault Location Flow Chart (Step 6)	5-5

6.	Specifications	6-1
	■ Physical Dimensions	6-2
	■ Electrical	6-2
	■ Access Line Interface (Ground Start)	6-2
	■ No Test Trunk Interface	6-3
	■ Test Function Parameters	6-4

Overview

1

Contents

Description	1-2
■ Direct Access Test Unit - Remote Terminal	1-3
■ Pair Gain Applique IIS	1-3
■ Metallic Access Unit	1-3
User Options	1-4
System Features	1-5

Description

The Direct Access Test Unit - Remote Terminal (DATU-RT) System (or RT System) extends the field technician's testing capabilities of subscriber lines through the non-metallic environment of a pair gain system. Typical Pair Gain Systems include SLC-96, SLC-Series 5, etc. The RT system has three major components (see Figure 1-1): the DATU-RT, the Pair Gain Applique II SPOTS (PGA IIS), and the remotely located Metallic Access Unit (MAU).

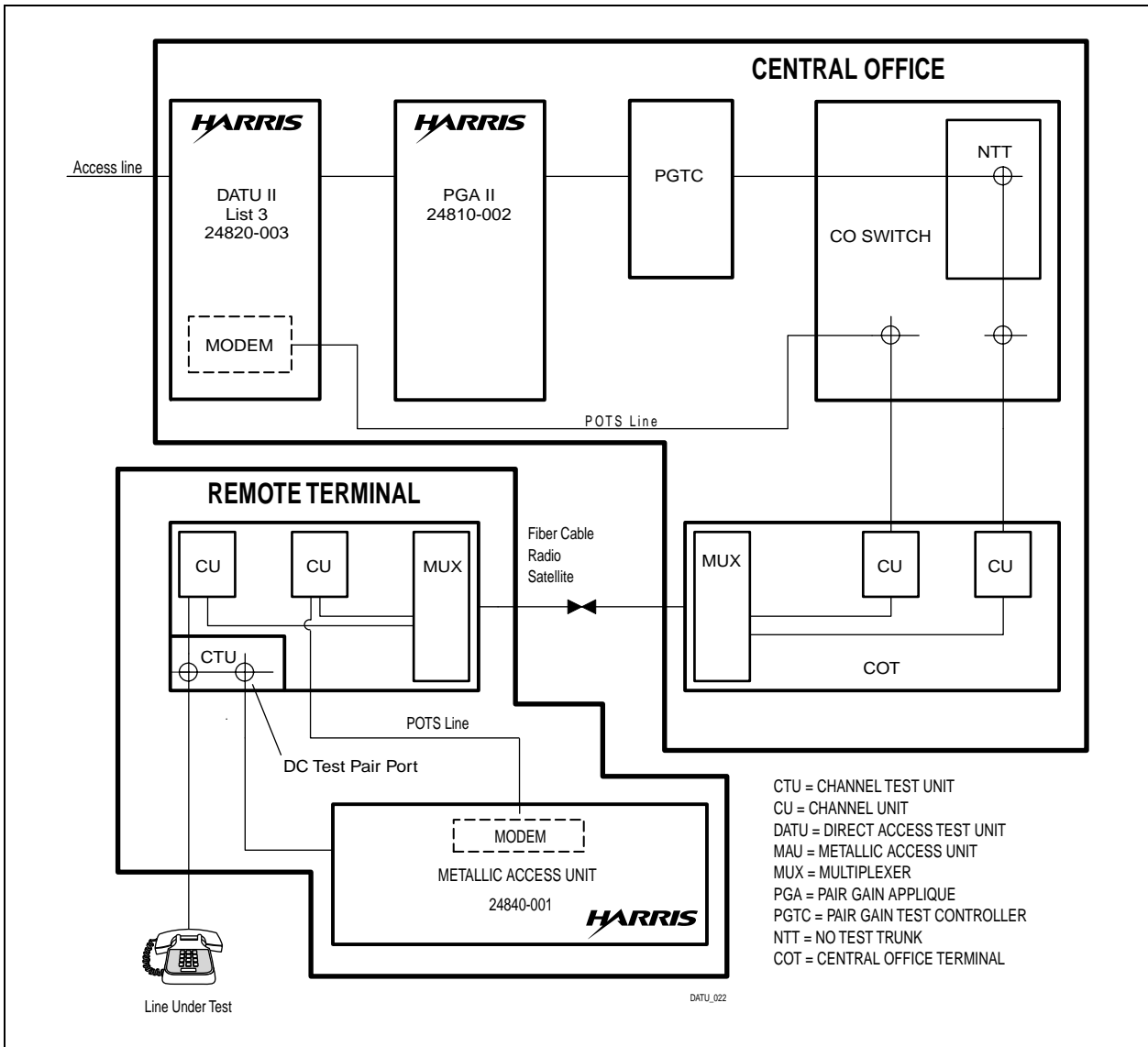

Figure 1-1. DATU-RT System Application Diagram

Direct Access Test Unit - Remote Terminal

Note: If the switch does not have a MFT bay, a Harris two-card card file, part number 25460-002, is available. This file is designed to mount into a 19 or 23-inch rack and takes two standard mounting spaces.

The DATU-RT is a printed circuit card that provides microprocessor control of line preparation functions, voice prompted menus and status reports to the technician. It allows technicians to access and perform specific loop conditioning and tone generating functions on any working subscriber line to prepare the line for use with field test equipment. The card is installed in the Metallic Facility Terminal (MFT) bay and connected to the Central Office (CO) switch. This Service Manual provides the description, installation, programming, and operation of the DATU-RT.

Other models of the DATU may be upgraded into a DATU-RT, but the original DATUs (part numbers 24800-002 through -008) are not upgradeable nor compatible with the RT System.

Pair Gain Applique IIS

The PGA IIS is a printed circuit card that extends the DATU-RT capabilities into the pair gain environment and serves as the interface between the DATU-RT and the switch's Pair Gain Test Controller (PGTC). It determines the status of the PGTC and its metallic DC test pair, provides carrier channel signaling and transmission test results, and controls the DATU-RT's access to the MAU. The card is installed in the MFT frame and connected to the switch. The *Pair Gain Applique II SPOTS Service Manual* provides the description, installation, and operation of the PGA IIS. Earlier models of the PGA (PGA I) card are not compatible with the RT system.

Metallic Access Unit

The MAU is a printed circuit card mounted in a protective metallic enclosure that provides the standard DATU-RT line conditioning functions as directed by the DATU-RT. It eliminates the need for metallic bypass pairs from the switch to the remotely located Pair Gain terminal. The enclosure is installed inside the cabinet housing the pair gain equipment. The *MAU Service Manual* provides the description, installation, and operation of the MAU.

One DATU-RT and one PGA IIS, working together in the same switch, may serve a maximum of 212 separate MAU locations.

The RT System provides the technicians the ability to perform a series of line preparation functions to subscriber lines. These functions are established and maintained by authorized personnel.

User Options

Using the RT System, the technician, working from a location in the field, can set up the following conditions on the line:

Audio Monitor—Audio Monitor allows the technician to monitor traffic on a busy line. During Audio Monitor, traffic on a busy line is scrambled so that it is audible but unintelligible. (Not available on a Pair Gain line.)

Open Line—The subscriber line is opened by removing battery and ground. (Not available on a busy line.)

Short Line—A metallic short is placed across the tip and ring of the subscriber line. (Not available on a busy line.)

Short-to-Ground—This feature establishes a metallic connection between tip, ring, and ground. (Not available on a busy line.)

Tip-to-Ground—This feature establishes a metallic connection between tip and ground with the ring open. (Not available on a busy line.)

Ring-to-Ground—This feature establishes a metallic connection between ring and ground with the tip open. (Not available on a busy line.)

High Level Test Tone—This is a high level, 577 Hz, metallic-tracing tone, and is interrupted four times per second for identification purposes. (Not available on a busy line.)

High Level Tone on Tip—This is a high level test tone that is placed only on the tip side of the line, with the ring side grounded. (Not available on a busy line.)

High Level Tone on Ring—This is a high level test tone that is placed only on the ring side of the line, with the tip side grounded. (Not available on a busy line.)

Low Level Test Tone—This is a low level, 577 Hz, longitudinal tracing tone that is used for busy line identification. It will not disturb traffic on a busy circuit. This tone is interrupted four times per second for identification purposes, and may be applied even if the line under test is busy. A standard technician's hand-held test set can be used to monitor this tone by connecting from tip to ground or ring to ground. (Not available on a Pair Gain line).

Hold—The Hold feature is used to continue a line preparation function after disconnecting from the RT System's access line, for a technician's specified time within the system's parameters. System parameters are set in the System Mode by authorized personnel (see System Features in this section). If a hold time is not entered, the RT System will automatically hold the function for one-half the maximum time limit set in the System Mode.

New Subscriber Line—This feature allows the technician to release one subscriber line and access another without disconnecting and re-accessing the RT System.

Permanent Signal Release—Used in Step-by-Step offices, this feature removes battery and ground on a permanent signal lines. It is used only on busy lines.

Forced Disconnect—Forced Disconnect allows the technician to disconnect from the RT system at any time by dialing "##".

System Features

Authorized personnel perform system programming functions that configure the RT system to operate with the switch and set and maintain the passwords, counters, and timers.

System Password—The System or authorized personnel's password is required to access to the System functions. It is a seven-digit number, preceded by a Dual-Tone Multi-Frequency (DTMF) "*", that is programmed into the RT System and can be changed as necessary.

User Password—The User or technician's password is required to access all RT system line preparation functions. The User password is a four-digit code that can be changed in the System Mode.

Dialing Method—Either multi-frequency (MF) or dial pulse signaling to the No Test Trunk (NTT) with wink, reversal sensing (half-wink), or no wink may selected. Provisions are included to accommodate the special dialing methods of other switches.

Prefix Table—The RT System must be programmed for those subscriber line prefixes that will be accessed. A total of 30 three-digit prefixes can be programmed.

Number of Digits to Access Subscriber Line—This feature sets the number of digits required by the switch at the incoming trunk level to access the subscriber line: 4, 5, 7, or 0 (for 10).

Access, Job, and Function Counters—The RT system provides the following event counters:

- **Access**—Records the number of times the User password has been successfully entered.
- **Job**—Records the number of times the DATU-RT successfully connects a subscriber line number to the NTT.
- **Single Line Access**—Records the number of times the DATU-RT connects the NTT to the line being used to access the DATU-RT.
- **Function**—Records the total number of times each individual line preparation function has been requested.

Note: When alarm condition is due to RT system failure, operation of Clear Alarm feature will not clear external alarm.

Enable/Disable Permanent Signal Release—The permanent signal release function may be either enabled or disabled.

Clear Alarm Condition—There are three conditions that will generate an alarm. These conditions are:

- Failing on three consecutive attempts to drop the NTT.
- Sixteen consecutive unsuccessful attempts to enter a User or System password.
- RT System failure.

Access Time Out Parameter—This feature sets the maximum amount of time per access a technician can use the NTT to test a subscriber line.

Access, Job and Function Timers—The RT System provides the following activity timers that measure total activity time in hours and minutes:

- **Access (Normal)**—This timing period begins when the technician enters a valid password and ends when the RT System becomes idle.
- **Access (Single Line)**—This timing period begins when the hold time set by the technician during single line access preparation starts, and ends when the RT System becomes idle.
- **Job**—This timing period begins when the dialed subscriber line is connected to the NTT and ends when the technician disconnects or enters a pound (#) to access a new subscriber line.
- **Function**—This timing period begins when the technician enters dial code for a line preparation function. The time period ends when another line preparation function is requested or upon disconnecting from the RT System.
- **Pair Gain System Record Table**—The RT System must be programmed for the Pair Gain Systems and Pair Counts that will be used. A total of 212 Pair Gain System Records may be programmed into the RT System.

Installation

2

Contents

Considerations for Installation	2-2
■ All Central Offices	2-2
■ NEAX-61	2-4
■ 2B ESS	2-5
■ DMS-10 and DMS-100	2-5
■ 5 ESS	2-5
Installation Procedures	2-6
■ PGA and MAU Installation Instructions	2-6
■ General Installation Procedures	2-6
■ Set Option Switches	2-8
■ Install in MFT Bay	2-8
■ Indication LEDs	2-8
■ Access Line	2-9
■ Modem Line	2-9
■ No Test Trunk	2-9

Considerations for Installation

The DATU-RT is compatible with most CO switches (see Table 2-1). For specific information concerning switch compatibility, contact the Harris Technical Support Team.

Table 2-1. List of NTT Circuit Numbers

Manufacturer	Switch	Circuit Number	
Lucent Technologies	1A ESS	SD-1A186-01	
	2B ESS	SD-2H109-01	
	3B ESS	SD-3H520-01	
	5 ESS	SN107	
	1 Crossbar	SD-25432-01	
	5 Crossbar	SD-26136-01	
	Step-By-Step		SD-31401-01
			SD-31402-01
		SD-32007-31	
Ericsson	AXE HOST, AXE RSS	ILTSI SLCT ACCSD	
NEC	NEAX-61	DLTT-S4900D	
Nortel Networks	DMS-10 With MLT	2T16/2T14	
	DMS-100 With MLT	2X90AC/AD	
Siemens	EWSD	MTAM	
Stromberg-Carlson	DCO	S814685-526	
		S814686-526	
	RLS 4000	S822040-526	

All Central Offices

1. Make the translations for RT system look exactly like the Mechanized Loop Testing (MLT) trunk, except, of course, for the trunk group number.
2. Optional ground source for line conditioning function:
 - With J2 installed (factory provided) on the DATU-RT, the ground supplied to the MFT bay is the ground source for the RT system line conditioning functions.
 - To provide an external ground source for the RT system line conditioning functions, remove the J2 shorting pin on the DATU-RT and connect the appropriate ground to R1/B (A side) on the MFT bay (DATU-RT pin 5), refer to Figure 2-1.
 - For all switches except the GTD-5, verify that S1 on the DATU-RT is set to the STD position.

Note: Refer to Figure 2-2 for the location of J2.

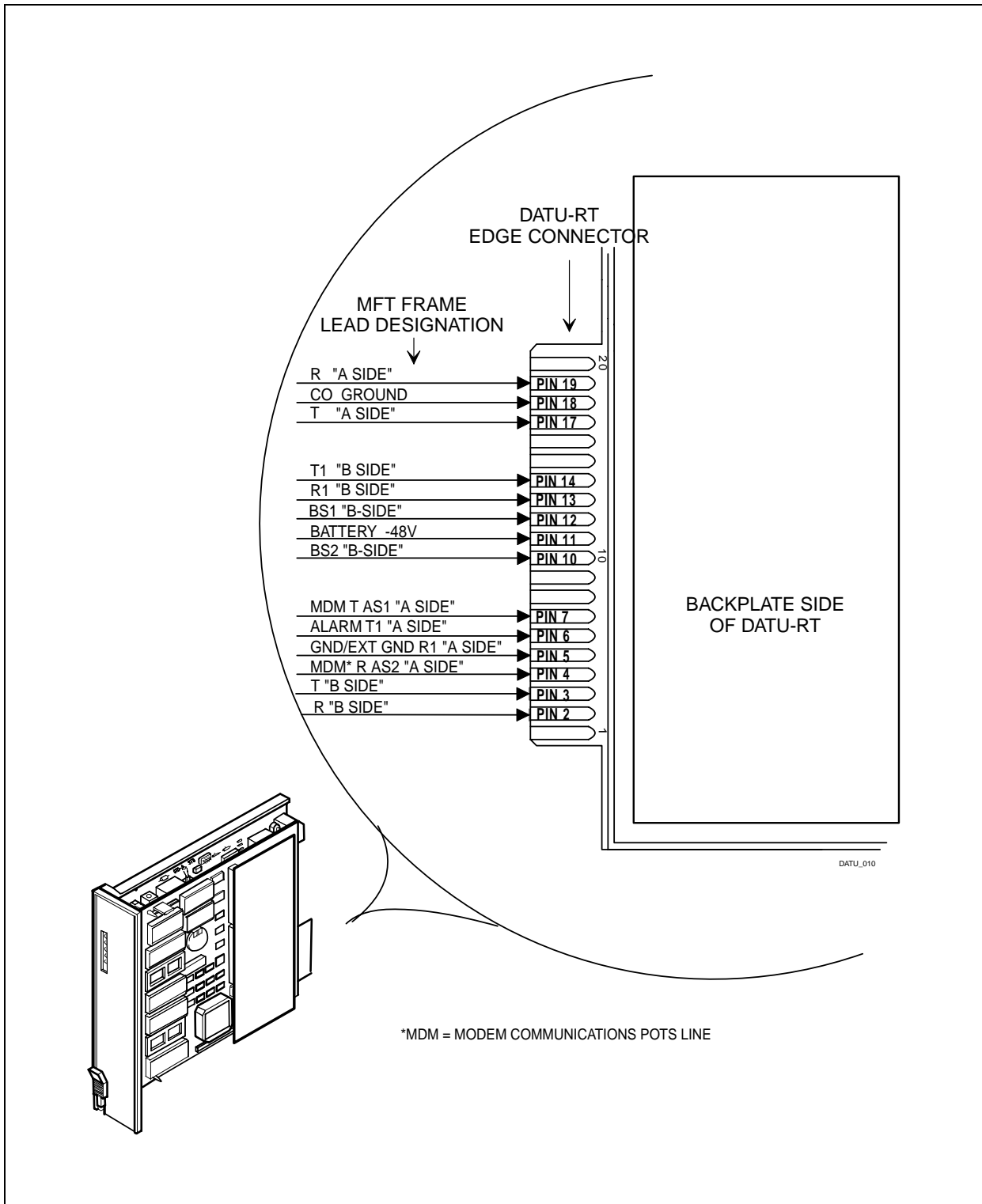

Figure 2-1. DATU-RT Card Pin Locations

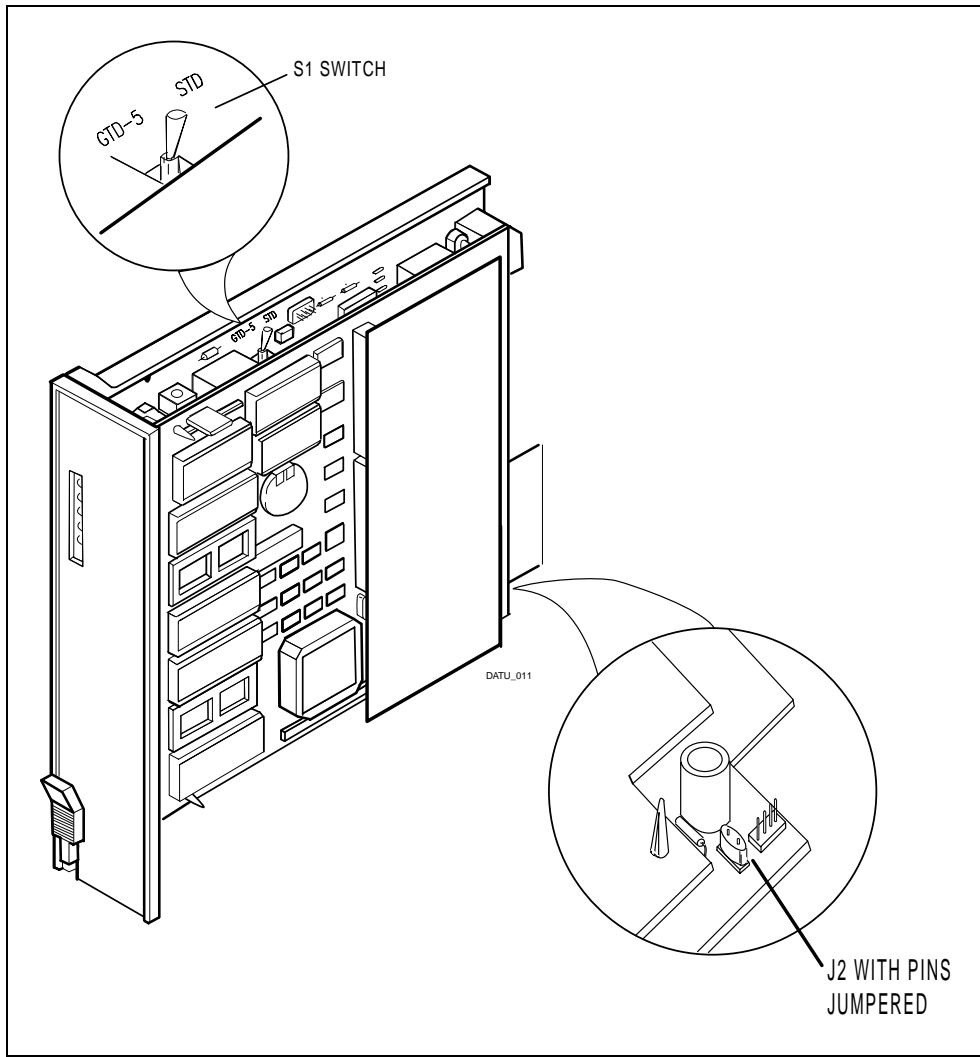

Figure 2-2. DATU-RT J2 and S1 Switch Locations

Note: Trunk translations are normally available from the Switch Configuration Center (SCC).

- DATU-RT System requires the same type of NTT translations as used by MLT. Table 2-1 shows the typical trunk circuit associated with most switches.

NEAX-61

Select 5 ESS busy test.

2B ESS

Many smaller switches do not have the BS1 and BS2 leads extended to the frame. "P" wire may be used to extend these leads to simplify the RT system installation.

DMS-10 and DMS-100

Should the ground start access line fail to release upon disconnect, add incoming service only to the translation table. If line release failures continue, then add Cut Off on Disconnect (COD). This drops the linkage when either party disconnects.

On some DMSs, setting the line translations for ground start will not be accepted by the switch. In this case, remove all translations, then rebuild.

Very old DMS-10s may have line cards that cannot be set for ground start. Replace these older line cards with T44 or later issue line cards for the access line.

On both DMS-10 and DMS-100, make sure the Tip and Ring pair is run between the NTT and the Metallic Test Access (MTA). Also, make sure instructions are set in memory that tell which horizontal to use in the MTA.

5 ESS

To ensure that the remote Pair Gain System is accessible by the PGTC and TBCU, one of the following generic/maintenance upgrades in the 5 E must be installed:

*Note: BG=Base Generic,
MU=Maintenance Upgrade.*

BG:	5E2(2)	MU 02.01 or later.
BG:	5E3(1)	MU BWM 87127 or later.
BG:	5E4	Programmed not to check BPP confirmation per remote.
BG:	5E5	Programmed not to check BPP confirmation per remote.

Installation Procedures

PGA and MAU Installation Instructions

Refer to the *PGA IIS Service Manual* and the *MAU Service Manual* for installation instructions.

General Installation Procedures

The DATU-RT is a plug-in printed circuit card that installs in a single slot of the MFT shelf and is connected to a NTT. See Figure 2-3, Figure 2-4, and Figure 2-5 for typical connections for the appropriate switch.

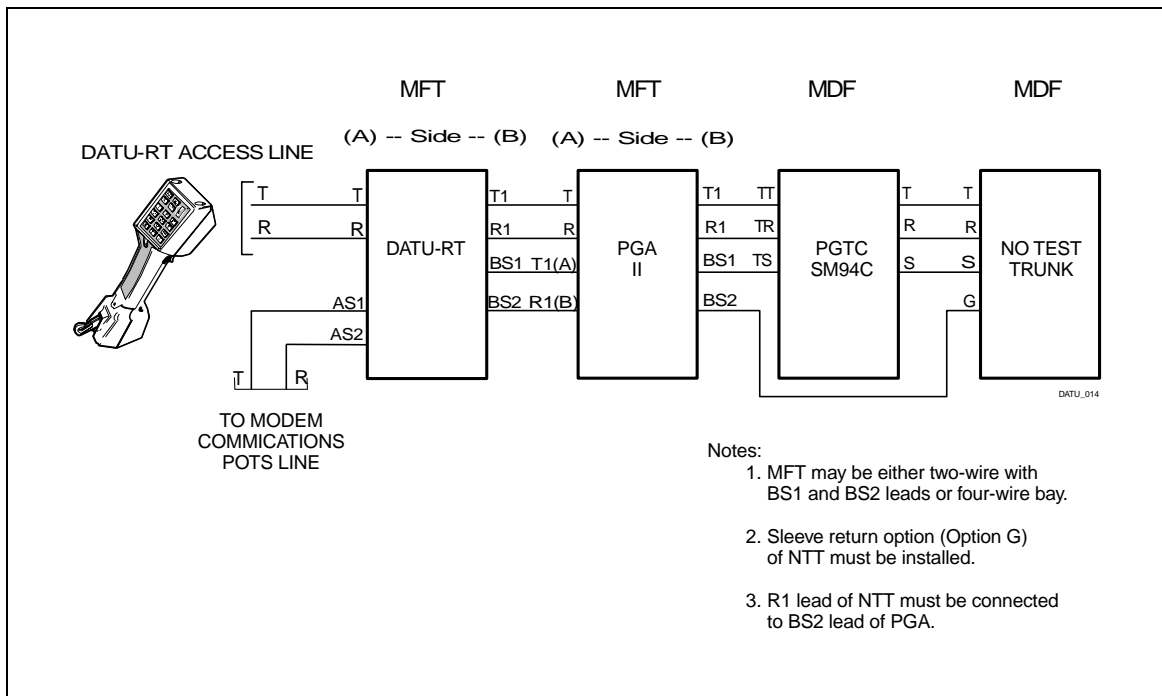

Figure 2-3. Connections for All Systems Except 5 ESS with Integrated SLC Only, DMS-10 and DMS-100

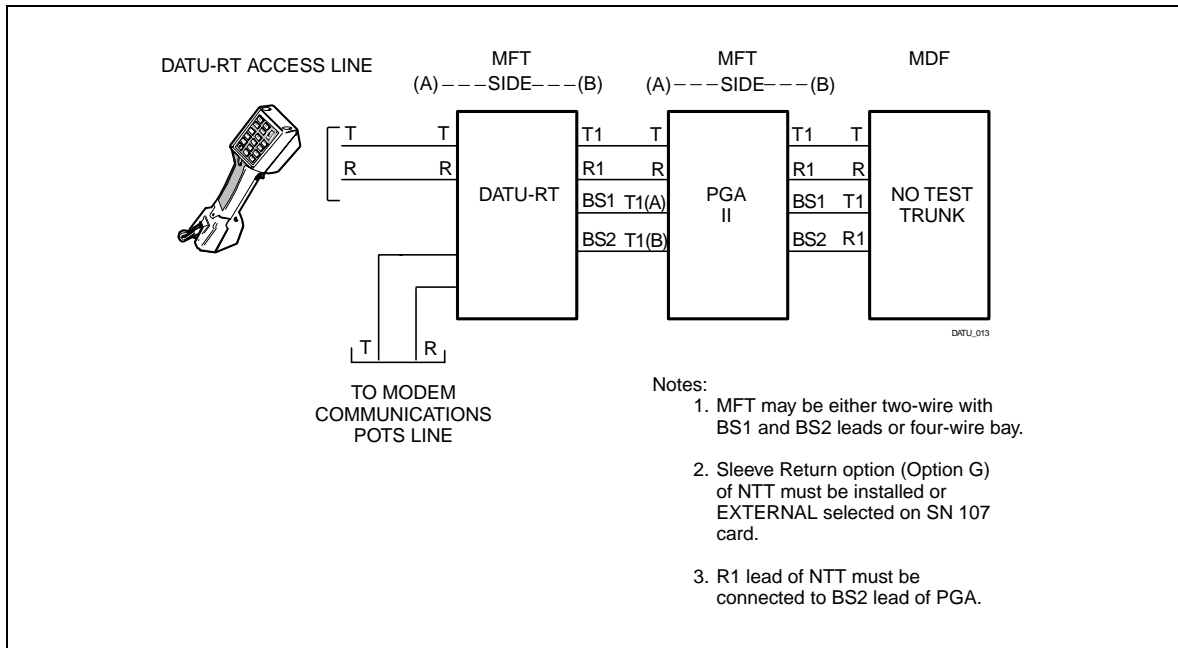

Figure 2-4. System Connections for 5 ESS with Integrated SLCs Only

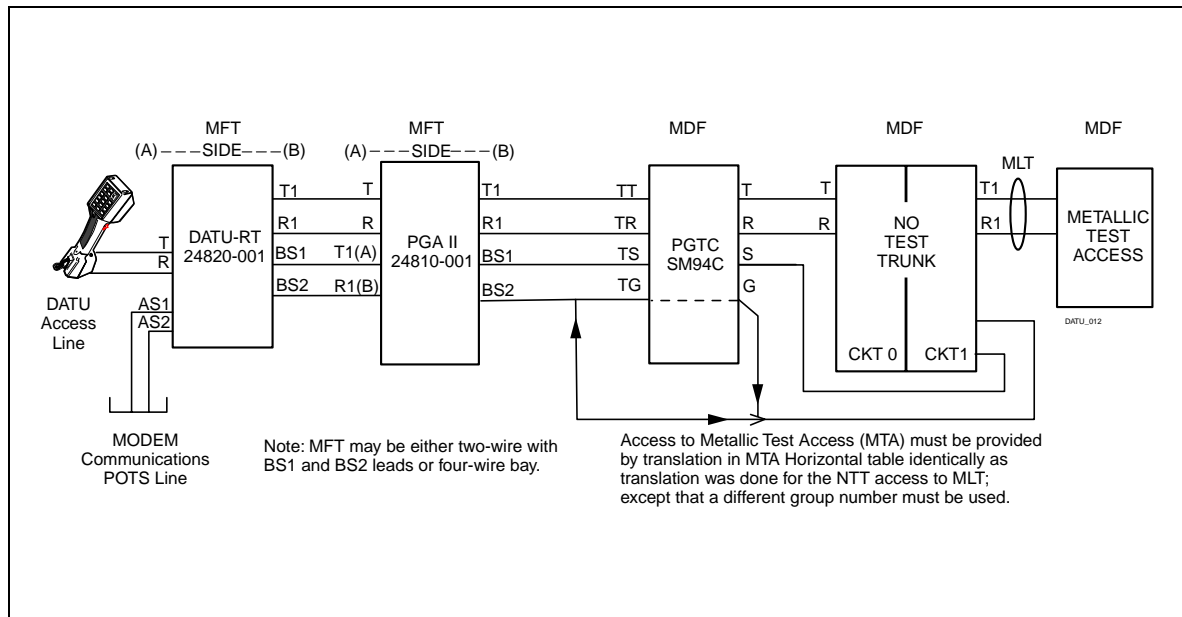

Figure 2-5. DMS-100 MDF Connections

Set Option Switches

Switch S1 (see Figure 2-2) must be set to the STD position. When an external ground is supplied for the DATU-RT line preparation functions, the jumper block on shorting pin J2 (see Figure 2-2) must be removed.

Install in MFT Bay

Note: When using double slot MFT shelves, mount the DATU-RT in the Transmission (TU) slot.

The card edge of the DATU-RT is designed to plug directly into the MFT bays when wired in the standard configuration. Plug the DATU-RT in the assigned MFT slot and the DATU-RT will power up automatically.

Indication LEDs

The five LEDs on the front panel of the DATU-RT (see Table 2-2) provide the visual status of the DATU-RT. The Power LED should illuminate and the Status LED should continuously flash on and off at 60 interruptions per minute.

Table 2-2. LED Functions

LED		Function
Label	Color	
Power	Yellow	On — Power Available Off — No Power
Alarm	Red	Off — No Alarm Condition On — One of Two Conditions Exist: 1. There have been 16 unsuccessful attempt to dial either the User or System Password, or 2. NTT is not releasing (see Note).
Status	Green	Flashing — DATU-RT is functioning normally. On — With Alarm LED On, a microprocessor failure. Off — With Alarm LED On, a microprocessor failure.
Hi Sleeve	Yellow	On — High Sleeve Current to NTT. Off — No or Low Sleeve Current to NTT.
Lo Sleeve	Green	On — Low Sleeve Current to NTT. Off — No or High Sleeve Current to NTT.
<p>Note: There have been at least three unsuccessful attempts by the DATU-RT to release the NTT. When the DATU-RT is accessed, a TRUNK DISCONNECT ERROR message will be provided. DATU-RT will continue to attempt to release the NTT with a low and high sleeve current sequence. When the NTT is released, the DATU-RT alarm will automatically clear.</p>		

Access Line

Access to the DATU-RT is from a dedicated ground-start telephone line and its Line Equipment Number (LEN) is wired to the MFT terminal on the horizontal side of the Intermediate Distribution Frame (IDF). Translated for terminate only, calling party control and short time out (i.e., ground start configuration).

Modem Line

The DATU-RT requires a dedicated origination telephone line to access the modem of the distant MAU. The LEN of this DATU-RT modem line, is wired to the MFT terminal on the horizontal side of the IDF.

No Test Trunk

The DATU-RT requires the same configuration of No Test Trunk (NTT) as used by MLT. Trunk translations for DATU-RT must be the same as the trunks used for MLT except for the assignment of a different trunk group number. The NTT is wired to the MLT terminal on the horizontal side of the IDF.

Programming System Functions

3

Contents

Programming Procedures	3-5
■ Setting System Password	3-6
■ Setting User Password	3-6
■ Selecting Busy Test	3-7
■ Selecting Dialing Method	3-7
■ Selecting Trunk Sleeve Sensing	3-7
■ Selecting Busy Test Timer (Issue 4 and Later)	3-8
■ Reading or Changing Prefixes	3-9
■ Reading or Clearing Timers	3-10
■ Setting Number of Digits to Select Subscriber Lines	3-11
■ Setting Access Time Out Parameters	3-11
■ Reading or Clearing Counters	3-12
■ Enabling or Disabling Permanent Signal Release	3-12
Split Pair Gain Systems Overview	3-13
■ Testing with Split Pair Gain Systems	3-15
■ Programming Procedures and Tips	3-15

Time Outs and Disconnects

3-27

- Dialing a System or User Password 3-28
- User Mode 3-28
- System Mode 3-28

Note: After the programming of the DATU-RT has been completed, follow the fault location flow diagram (Figure 5-1) and the RT System verification diagram (Figure 5-2) to prove out the installation.

Authorized personnel may change any of the factory-provided System functions (see Table 3-1) by accessing the System Menu (see Table 3-2) and using standard DTMF Dial Codes. The menu options may be selected in any order.

During the programming of System functions, no changes to the DATU-RT parameters are made until the DATU-RT asks for the confirmation with the voice prompt **DIAL POUND IF OK**. A pound (#) sign entered at this point causes the programming to take effect and returns to the Main Menu. Any other entry abandons the operation. Whenever the Main Menu is accessed or re-accessed a 440 Hz tone is provided.

To move from the System (authorized personnel) functions to Line Preparation (technician) functions, the existing connection to DATU-RT must be released and re-established.

When disconnecting from the DATU-RT, if the access line does not have calling party control, use the forced disconnect feature by entering ## and go on-hook immediately.

Table 3-1. Factory-Provided System Function Values

Program Function	Values
System Password	2222222
User Password	1111
Prefix Table	Empty
Job, Access, and Function Counters	0000
Dialing Method	MF with Wink
Number of Digits	7
Access Time-Out	10 Minutes and Resettable
Permanent Signal Release	Disabled
Pair Gain System Record Table	Empty
Note: Program function values are stored in permanent memory, except the System password is reset to 2222222 whenever the power is removed from the DATU-RT for more than seven seconds.	

Table 3-2. System Menu Parameters

Main Menu		First Sub Menu		SECOND SUB MENU		Third Sub Menu					
Dial Code	Description	Dial Code	Description	Dial Code	Description	Dial Code	Description				
1	To Change Passwords	1	Set System Password								
		2	Set User Password								
2	Select Busy Test/ Dialing Method/Trunk Sleeve Sensing	1	Select Busy Test	4	Standard Busy Test						
				5	5 ESS Busy Test						
				6	Special Busy Test [†]						
		2	Select Dialing Method	3	Select Trunk Sleeve Sensing			1	MF w/Wink		
								2	MF		
								3	Pulse w/Wink		
								4	Pulse		
								5	MF w/Reversal Sensing		
								6	Pulse w/Reversal Sensing		
		3	Busy Test Timer ²	4	Add Prefix			1	Usage Timers	1	Trunk Share
								2	Special Trunk Sleeve Sensing ¹	2	No Trunk Share
		3	Read or Change Prefixes	3	Delete All Prefixes						
5	Read All Prefixes										
6	Read All Prefixes										
4	Read or Clear Timers	1	Read Timers	1	Usage Timers						
				2	Function Timers						
		2	Clear Timers	1	Usage Timers						
				2	Function Timers						
				3	Clear All Timers						
		5	Set Number of Digits to Select Subscriber's Line	4, 5, 7, or 0 (for 10) for number of digits							
6	To Set Access Time Out Parameters	0 or 1 01 to 99	0 = reset timer, 1 = won't reset timer. 2 digit code for number of minutes.								
7	To Read or Clear Counters	1	Read Counters	1	Usage Counters						
				2	Function Counters						
		2	Clear Counters	1	Usage Counters						
				2	Function Counters						
				3	Clear All Counters						

Notes:

- 1. Select Special Trunk Sleeve Sensing for Stromberg DCO Switches.
- 2. Issue 4 or later feature.

Table 3-2. System Menu Parameters (Continued)

Main Menu		First Sub Menu		Second Sub Menu		Third Sub Menu	
Dial Code	Description	Dial Code	Description	Dial Code	Description	Dial Code	Description
8	To Enable or Disable Permanent Signal Release	For Step-By-Step or Crossbar Switches Only					
9	Read or Change Pair Gain System Parameters	1	See Setting Pair Gain System Record(s)	S	With By-Pass Pair		
		2	See Reading One Pair Gain System Record	0	No By-Pass Pair		
		3	See Reading All Pair Gain System Records				
		4	See Deleting One Pair Gain System Record				
		5	See Deleting All Pair Gain System Records				
		6	See Adding Pair Count Record(s)				
		7	See Deleting One Pair Count Record				
		8	See Setting the RT System Baud Rate ³				
0	To Clear Alarm						
Notes: 3. Enter 1200 for 1200 baud or enter 300 for 300 baud. 4. When programming the DATU-RT, the term WINK refers to (1) the reversal of trunk polarity which occurs when a termination is placed across T/R, followed by (2) the re-reversal of trunk polarity after all the digits have been dialed. Reversal Sensing" refers to just the initial reversal (no re-reversal will be expected if the DATU-RT is set for Reversal Sensing).							

Programming Procedures

To access the DATU-RT System Menu, follow the steps below:

1. Dial the DATU-RT access number. The DATU-RT will trip the ring and return a 440 Hz acknowledgment tone.
2. Enter * and the System password. The factory-provided System password is 222222 (seven 2s). The DATU-RT will prompt **OK** followed by the Main Menu access tone.

Note: After 7 seconds, if no dial codes have been entered, the DATU-RT will start prompting with the System Menu options every 7 seconds for 10 minutes.

Setting System Password

To set the System password:

1. Enter **1** and DATU-RT will respond **DIAL ONE TO SET SYSTEM PASSWORD. DIAL TWO TO SET USER PASSWORD.**
2. Enter **1** again and DATU-RT will respond **DIAL SEVEN DIGITS.**
3. Enter the new System password and DATU-RT will respond **REPEAT.**
4. Enter the System password again. It must be repeated exactly. If the first and second entries match, DATU-RT will respond **DIAL POUND IF OK.** If the entries don't match, DATU-RT will respond **ERROR** and return to Main Menu.
5. Enter **#** and select a new item from the Main Menu.

Note: The confirming "#" must be entered before the entry becomes active. Any other entries will cancel the change.

Setting User Password

To set the User password:

1. Enter **1** and DATU-RT will respond **DIAL ONE TO SET SYSTEM PASSWORD. DIAL TWO TO SET USER PASSWORD.**
2. Enter **2** and DATU-RT will respond **DIAL FOUR DIGITS.**
3. Enter the new User (technician) password and DATU-RT will respond **REPEAT.**
4. Enter the new User password again. It must be repeated exactly. If the first and second entries match, DATU-RT will respond **DIAL POUND IF OK.** If the entries don't match, DATU-RT will respond **ERROR** and return to the main menu.
5. Enter **#** and select a new item from the Main Menu.

Selecting Busy Test

To select busy test:

1. Enter **2**. The DATU-RT will respond **DIAL ONE TO SELECT BUSY TEST, DIAL TWO TO SELECT DIALING METHOD, DIAL THREE TO SELECT TRUNK SLEEVE SENSING**.
2. Enter **1**. The DATU-RT will announce **DIAL FOUR TO SELECT STANDARD BUSY TEST, DIAL FIVE TO SELECT 5ESS BUSY TEST, DIAL SIX TO SELECT SPECIAL BUSY TEST**.
3. Dial the appropriate code. Use the 5ESS Busy Test for NEAX-61 and #5 ESS switches; use the special busy test for DMS switches with integrated DLC; and use standard busy test for all others. The DATU-RT will repeat the selection then prompt **DIAL POUND IF OK**.
4. Enter **#** and select a new item from the Main Menu.

Selecting Dialing Method

To select dialing method:

1. Enter **2**. The DATU-RT will respond **DIAL ONE TO SELECT BUSY TEST, DIAL TWO TO SELECT DIALING METHOD, DIAL THREE TO SELECT TRUNK SLEEVE SENSING, DIAL FOUR TO SELECT BUSY TEST TIMER**.
2. Enter **2** again and DATU-RT will announce the available Dialing Method options.
3. Enter the appropriate code (see Table 3-2 for options). DATU-RT will repeat the selected option and respond **DIAL POUND IF OK**.
4. Enter **#** and select a new item from the Main Menu.

Selecting Trunk Sleeve Sensing

To select trunk sleeve sensing:

1. Enter **2**. The DATU-RT will respond **DIAL ONE TO SELECT BUSY TEST, DIAL TWO TO SELECT DIALING METHOD, DIAL THREE TO SELECT TRUNK SLEEVE SENSING, DIAL FOUR TO SELECT BUSY TEST TIMER**.

-
2. Enter **3**. The DATU-RT will respond **DIAL ONE TO SELECT STANDARD TRUNK SLEEVE SENSING, DIAL TWO TO SELECT SPECIAL TRUNK SLEEVE SENSING**. Dial the appropriate code. Use special sleeve sensing for Stromberg DCO switches.
 3. If the dial code **2** is entered, the DATU-RT will prompt **DIAL ONE IF TRUNK SHARE, DIAL TWO IF NO TRUNK SHARE**. If a Harris Trunk Share Applique is being used with the DATU-RT, dial **1**. Otherwise dial **2**.
 4. The selected sleeve sensing type will be repeated, followed by **DIAL POUND IF OK**.
 5. Enter **#** and select a new item from the Main Menu.

Selecting Busy Test Timer (Issue 4 and Later)

This optional function is used with the Special Busy Test (used with DMS switches which have integrated DLC). The busy test timer controls the length of the delay between no-test trunk cut through to the line and the DATU-RT busy test on the line.

1. Enter **2**. The DATU-RT will respond **DIAL ONE TO SELECT BUSY TEST, DIAL TWO TO SELECT DIALING METHOD, DIAL THREE TO SELECT TRUNK SLEEVE SENSING, DIAL FOUR TO SELECT BUSY TEST TIMER**.
2. Enter **4**. The DATU-RT will read the current timer value in seconds <point> tenths of seconds (for example, **3 point 5** would mean that the timer is set to 3.5 seconds). The default is 0.0 seconds.
3. The DATU-RT will then prompt, **DIAL TWO DIGITS**. Enter the desired length of time in seconds followed by tenths of seconds. For example, enter **9 2** for 9.2 seconds.
4. The DATU-RT will read back the time entered then prompt **DIAL POUND IF OK**.
5. Enter **#** and select a new item from the Main Menu.

Reading or Changing Prefixes

Note: If the switch requires five digit access to the NTT, program the number of digits to access the subscriber's line as described in the "To Set Number of Digits Required To Access Subscriber Lines" paragraph before entering any prefixes.

This function is for entering, reading, and maintaining the office prefixes for the subscriber line numbers that the DATU-RT will be accessing.

1. Enter **3**. DATU-RT will announce the available Prefix options.

- a. Enter **3** to add a prefix.

Enter the three digit prefix and (if applicable) steering digit to be added to the prefix table. DATU-RT will repeat the prefix and steering digit, if provided, and prompt **DIAL POUND IF OK**. Enter a **#** to complete the addition of the prefix.

Enter the next prefix and (if applicable) steering digit and DATU-RT will respond as previously described. When the last prefix has been added and accepted, enter a **#** to select a new item from the Main Menu.

- b. Enter **4** to delete all prefixes.

DATU-RT will repeat the selected option and ask for a confirmation with the prompt **DIAL POUND IF OK**. Enter a **#** to delete all prefixes and select a new item from Main Menu. Enter any other key to cancel the delete all prefixes operation and return to Main Menu.

- c. Enter **5** to delete a single prefix.

Enter the three prefix digits to be deleted. DATU-RT will repeat the prefix and prompt **DIAL POUND IF OK**. Enter a **#** to complete the deletion of the prefix and to select a new item from the Main Menu.

- d. Enter **6** to read all prefixes.

DATU-RT will read all the prefixes and applicable steering digits from the Prefix Table and return to the Main Menu.

Reading or Clearing Timers

Note: When reading the timers, the DATU-RT will announce the function and then the time in hours and minutes. Example: ACCESS TIMER, ZERO FOUR FIVE SIX HOURS, FOUR THREE MINUTES. Maximum timer readout is 9,999 hours and 59 minutes. After each function timer is read, a # must be entered to go to the next timer in sequence. The # may be entered at any time but any other key will stop the readings and return to the Main Menu.

1. Enter **4** and DATU-RT will announce the available options.
 - a. Enter **1** to read Timers.
 - Enter **1** to read Usage* Timers.
 - Enter **2** to Read All Function Timers.
 DATU-RT will read the timers chosen.

*Note: Usage Timers are Access, Job, and Single Line Access.
 - b. Enter **2** to clear Timers.
 - Enter **1** to clear Usage Timers.
 - Enter **2** to clear Function Timers.
 - Enter **3** to clear **ALL** Timers.
 DATU-RT will repeat the timer to clear, then prompt **DIAL POUND IF OK.**
 - c. Enter **#** and select a new item from the Main Menu.

Table 3-3 is provided for record keeping convenience.

Table 3-3. Usage and Job Function Counter Timer Log

Line Preparation Function	Counts	Timer Reading	
		Hours	Minutes
Access			
Job			
Single Line Access			
Audio Monitor			
Tip and Ring Short-to-Ground			
Tip-to-Ground			
Ring-to-Ground			
Tip and Ring High-Level Tone			
Low-Level Tone			
Tip High-Level Tone			
Ring High-Level Tone			
Short Line			
Open Line			

Setting Number of Digits to Select Subscriber Lines

Note: Selecting zero from this submenu will cause the DATU to use 10 digit dialing through the NTT.

To set the number of digits to select subscriber lines:

1. Enter **5** and DATU-RT will respond **DIAL FOUR, FIVE, SEVEN, or Zero**.
2. Enter either **4, 5, 7, or zero** (for 10) depending on the number of digits required to access a subscriber line through the NTT. DATU-RT will repeat the digit chosen, then prompt **DIAL POUND IF OK**.
3. Enter **#** and select a new item from the Main Menu.

Setting Access Time Out Parameters

This feature is used to set the maximum period of time a technician may condition a subscriber's line. The factory default timer is 10 minutes with resetting of the timer permitted. The timer is started over or reset each time a key is pressed if the timer reset is allowed. **If a 10 minute, resettable timer is acceptable, skip the rest of this section.**

Note: The first digit is used to allow or prohibit the resetting of the access timer. Pressing a "0" will allow the timer to be reset. This means that every time the technician presses a key to call a function, the access timer will be reset to the number of minutes allowed. Pressing a 1 will prohibit the resetting of the timer in user mode. The last two digits are the maximum number of minutes, from 01 to 99 minutes, that the access timer will run. See Example 1 and 2.

1. Enter **6**. DATU-RT will respond **DIAL THREE DIGITS**.
2. Enter three digits (see Table 3-4 for available choices). DATU-RT will repeat the entry and prompt **DIAL POUND IF OK**.

Table 3-4. Timeout Parameters

Digit 1	Digit 2 Tens of Minutes	Digit 3 Whole Minutes
0 = Timer will reset	0-9	0-9
1 = Timer will not reset		

3. Enter **#** and select a new item from the Main Menu.

Example 1: Enter the three digits **110**.

This permits the technician to access the subscriber's line for a maximum of ten minutes to perform all tests on the line before the access timer will timeout, disconnecting the DATU-RT. The technician cannot extend this time period. The technician, when in the Hold After Disconnect function, may direct the DATU-RT to continue to hold the line for a maximum of ten minutes after going on-hook.

Example 2: Enter the three digits **004**.

This permits the technician to access the subscriber's line for a maximum of four minutes to perform individual tests on the line before the access timer will timeout, disconnecting the DATU-RT. Every time the technician selects the same or another test function, the access timer resets itself and another four minute disconnect sequence begins. The technician, when in the Hold After Disconnect function, may direct the DATU-RT to continue to hold the line for a maximum of four minutes after going on-hook.

Reading or Clearing Counters

To read or clear counters:

1. Enter **7** and DATU-RT will announce the available options.
 - a. Enter **1** to read Counters.
 - Enter **1** to read Usage Counters.
 - Enter **2** to read Function Counters.DATU-RT will read the counters chosen.

Note: When reading the counters, the DATU-RT will announce the function and then the number of accesses. Example: ACCESS COUNTER, ZERO FOUR FIVE SIX. Maximum counter readout is 9,999. After each counter is read, a # must be entered to go to the next counter in sequence. The # may be entered, at any time, but any other key will stop the readings and return to the Main Menu.

- b. Enter **2** to clear counters
 - Enter **1** to clear Usage Counters.
 - Enter **2** to clear all Function Counters.
 - Enter **3** to clear **ALL** Counters.

DATU-RT will repeat the counters to be cleared, then prompt **DIAL POUND IF OK**.

2. Enter **#** and select a new item from the Main Menu.

Enabling or Disabling Permanent Signal Release

To enable or disable permanent signal release:

Note: Permanent Signal Release requires access to a standard Permanent Signal Release Trunk.

1. Enter **8** to enable or disable permanent signal release. After the "8" is dialed the DATU-RT will prompt with the state that the permanent signal release will be changed to if **#** is entered. DATU-RT will then prompt **DIAL POUND IF OK**.
2. Enter **#** and select a new item from the Main Menu.

Split Pair Gain Systems Overview

If you are already familiar with Split Pair Gain Systems, skip to the section marked "Testing with Split Pair Gain Systems."

A Split Pair Gain System is one in which the same Pair Gain System has cable pairs at more than one metallic test path physical location (shown in Figure 3-1 as PG1056 in the Elm St. and 52nd St. locations). The DATU-RT accommodates this split by allowing multiple Cable Pair Counts (and Harris Remote Terminal Devices, [e.g., MAUs]) to be associated with each Pair Gain System ID. An example of a Split Pair Gain System is shown in Figure 3-1, Figure 3-2, and in Table 3-5.

An MLT test of a customer's line in this test path (see Figure 3-1) is accomplished via an Remote Measurement Unit (RMU) at the DLC Remote Terminal eliminating the Metallic Bypass Pair running between the DLC Remote Terminal and the Central Office (CO). In this instance an MAU is required for metallic conditioning of the customer's line.

Example (Part 1)

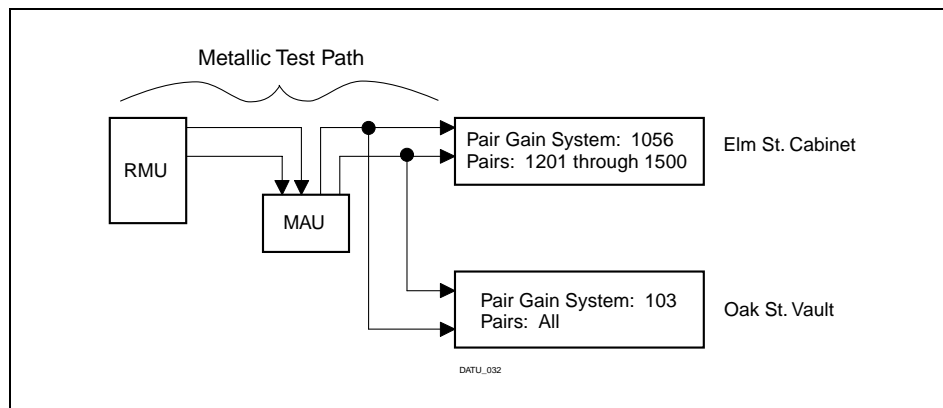

Figure 3-1. Testing with a Remote Measurement Unit

Example (Part 2)

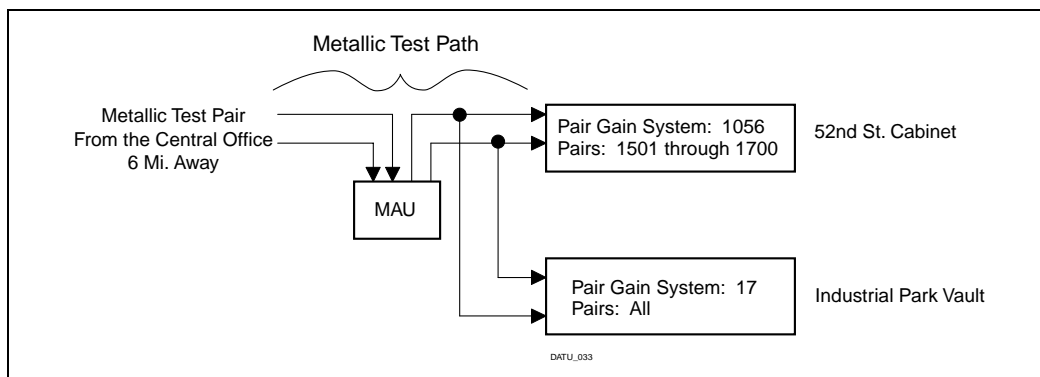

Figure 3-2. Testing with a Metallic Bypass Pair

Table 3-5. RT Table (Example from Figure 3-1 and Figure 3-2)

Comments	DLC Type	Site Ident.	Location	PG Cable	Counts	RT Access Telephone #	BP Pair (Y/N)	Test Number	Comments
----------	----------	-------------	----------	----------	--------	-----------------------	---------------	-------------	----------

<Enter the District or other identifier here>

<Office where DATU-RT RT is located>		<DATU-RT Access number>							
	SLC96	RMU #1	Elm St. Cabinet	1056	1201-1500	555-1111	N	<A DLC number in this cable and pair group>	
	DMS1U	RMU #1	Oak St. Vault	103	1-9999 (Just enter a star for all counts)	555-1111	N		
	SLC96	<Geo Code>	52nd St. Cabinet	1056	1501-1700	555-2222			
	DMS1U	<Geo Code>	Industrial Park Vault	17	1-9999 (Just enter a star for all counts)	555-2222			

An MLT test of a customer's line in this instance is accomplished via the Metallic Bypass Pair from the DLC Remote Terminal to the LTS at the CO (see Figure 3-2). A MAU may be placed in the test path eliminating the effect of the bypass pair which occurs when conditioning is performed at the CO end of the bypass pair.

In Figure 3-2 Pair Gain System ID 1056 is a Split Pair Gain System with:

Pair Count Start = 1201, Pair Count End = 1500	MAU 1	Location: Elm St.
Pair Count Start = 1501, Pair Count End = 1700	MAU 2	Location: 52nd St.

Pair Gain Systems 103 and 17 are not split.

Testing with Split Pair Gain Systems

DATU-RT accesses multiple MAUs within a single Pair Gain System (e.g., PG1056 in the examples on the previous page). The craftspeople need only supply the DATU-RT with the Pair Gain System (Cable) Identifier and the cable pair is being worked on. DATU-RT uses the split Pair Gain System information stored in the Pair Gain System Record Table to establish a test path, then conditions the line.

Programming Procedures and Tips

1. **Before programming the Pair Gain System records**, it is advisable to have all the information on the remote site's Pair Gain configuration handy. An example of how this information could be organized is provided below, using the information in Figure 3-1 and Figure 3-2. An example of a table for recording Pair Gain System information prior to programming the DATU is provided. Sorting by Pair Gain System ID simplifies data entry.
2. During programming, DATU-RT waits approximately 7 seconds for a keypad entry. After seven seconds have elapsed without a keypad entry, DATU-RT repeats the prompt. If a mistake is made, and it is caught before the confirmation or ending key is entered, stop and wait for seven seconds. The DATU-RT will disregard the entries prior to the stop and reprompt for the complete entry.
3. If an improper entry is entered during the programming of the unit, the DATU-RT responds with an error message, then returns to the main menu.
4. Avoid making entries during speech.
5. Once a complete Pair Count Record is entered, the DATU-RT repeats the entire record for confirmation. Enter a pound (#) to save the data in DATU-RT's memory; any other entry cancels the request.
6. The alpha mode is toggled on and off by dialing **. Once in alpha mode, each letter is entered by dialing two keys. The first key depression simply identifies the key on which the desired character is stamped or printed. The second key is the letter's position (1, 2, or 3) on the key. For example, the letter **E** would be represented by the keys **3 2** (the 3 key has the letters **DEF** on it and **E** is the second of the three letters). Refer to Table 3-6 for the letters that don't appear on a telephone keypad (such as Q or Z).

Table 3-6. Alpha Mode

1st Key	2nd Key				
	1	2	3	4	5
1	(SPACE)	(PERIOD)	(COMMA)	(DASH)	(SLASH)
2	A	B	C		
3	D	E	F		
4	G	H	I		
5	J	K	L		
6	M	N	O		
7	P	R	S	Q	
8	T	U	V		
9	W	X	Y	Z	

Example: To enter a Pair Gain System ID of ELM04

1. The DATU-RT requests the Pair Gain System ID.
2. Enter ** to toggle into the letter mode.
3. Enter **32**—the three is for the button labeled 3 DEF and the two is for the second letter (E) of the group DEF.
4. Enter **53**—fifth button and third letter of group JKL.
5. Enter **61**—sixth button and first letter of group MNO.
6. Enter ** to toggle back into the numeric mode.
7. Enter **04**.
8. Enter * to end Pair Gain System ID.

Setting Pair Gain System Records

After accessing the DATU with the System password perform the following steps to set Pair Gain System Records (see Figure 3-3).

1. Enter **9** to Read or Change Pair Gain System parameters. At this time the DATU-RT announces the available options.
2. Enter **1** to set Pair Gain System Record.

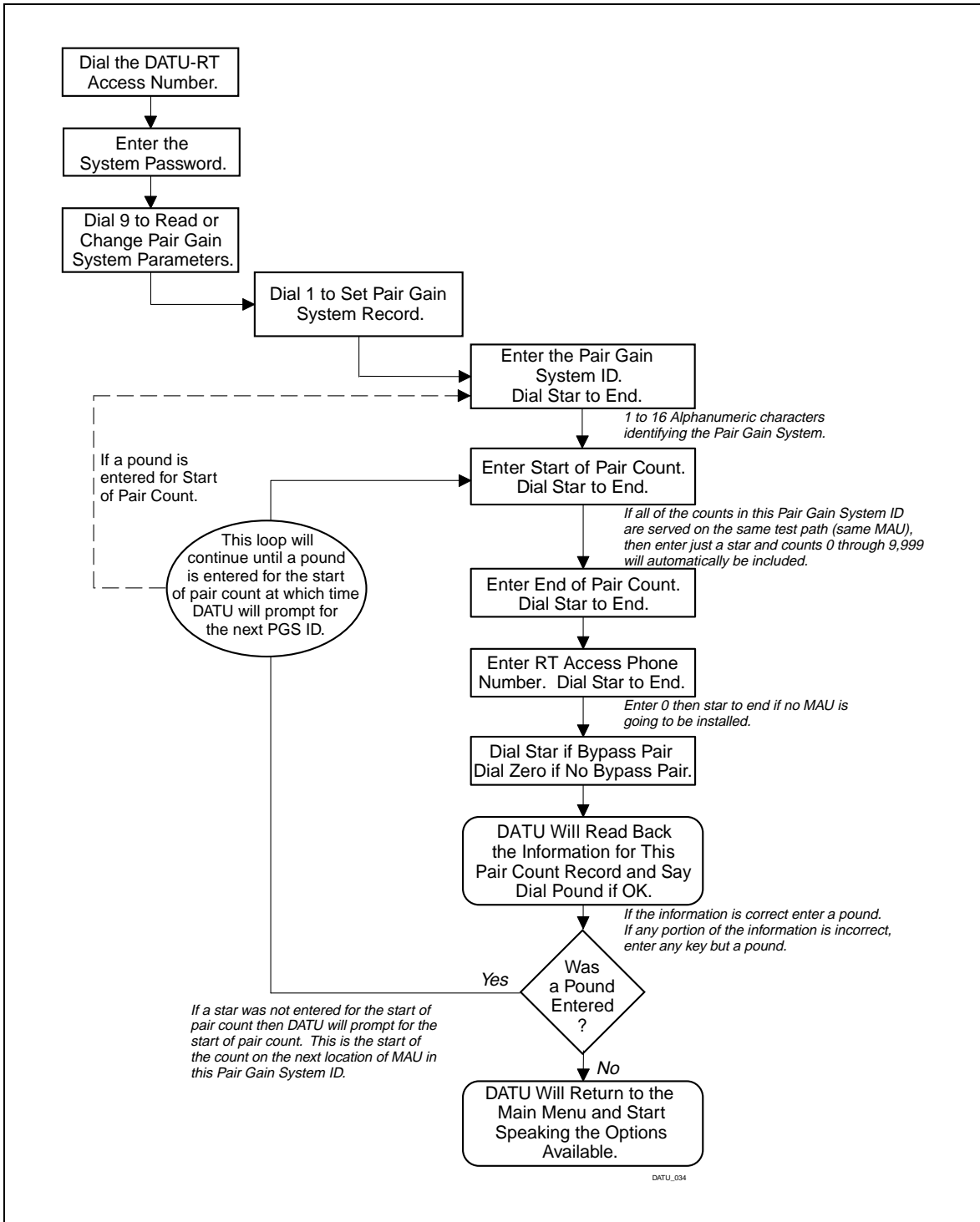

Figure 3-3. Setting Pair Gain System Record

Important: *If all of the pairs in this Pair Gain System ID are to be accessed by this one MAU then enter a star (*) at this time. By entering a star (*) pair counts 0 through 9999 are automatically associated with the PGS ID, DATU-RT does not prompt for end of pair count.*

3. **Pair Gain System ID**—DATU-RT prompts for the Pair Gain System ID (PGS ID). This entry can be up to 16 alphanumeric characters in length. For example, the Pair Gain System 1056 on Elm Street, could be entered as simply **1056** or with alphanumerics as **ELM**. The Pair Gain System Identifier should be entered in such a way as to allow the outside craftsperson to readily obtain this information from the trouble ticket. Do not use pound (#) or star (*) as a part of the PGS ID as these keys are reserved for other functions. Dial star (*) to end this portion of the entry.
4. **Start of Pair Count**—DATU-RT prompts for the start of pair count. This one to four digit value represents the lowest pair count associated with this Pair Gain System ID for a given metallic test path. Dial a star (*) to end this portion of the entry.
5. **End of Pair Count**—DATU-RT prompts for the end of pair count. This value is the highest pair count in this Pair Gain System ID programmed for this metallic test path (see example below). Enter a star (*) to end this portion of the entry.

Example: Pair Gain System 1056 has counts 1201 to 1500 on a single test path. 1201 should be entered as the Start Of Pair Count and 1500 should be entered as the End of Pair Count for this Pair Count Record.

6. **RT Access Phone Number**—DATU-RT prompts **ENTER RT ACCESS PHONE NUMBER, DIAL STAR (*) TO END**. This is the telephone number of the POTS channel unit assigned to the MAU at this location. The phone number may be 1 to 11 digits long but will more than likely be a standard 7 digits. If no MAU is installed enter **0** for the RT access phone number. Dial star (*) to end this portion of the entry.
7. **Bypass Pair**—DATU-RT prompts for the availability of the bypass pair. If a bypass pair is present enter a star (*). If there is no bypass pair to the remote site enter a zero (**0**).

Option Note: A MAU may be placed in a remote site that is served by a DC test pair to allow for metallic conditioning of the customer's drop without having to consider the test pairs length to the serving CO. By programming the presence of the test pair into the DATU-RT, the craftsperson has the option of using either the test pair or the MAU. The DATU-RT conditions the line with the MAU unless told to do otherwise, and prompts the craftsperson to enter star (*) to use the bypass pair if the DATU-RT cannot establish contact with the MAU.

8. **Confirmation**—DATU-RT reads back the entries for this PGS ID, then prompt **DIAL POUND (#) IF OK**. Press # to save the Pair Gain System entry, any other key cancels the request and returns the user to the main menu. After saving the Pair Count record (and prompting **OK**) the DATU-RT begins accepting data for the next pair count record for this Pair Gain System ID by asking for the next Start of Pair Count.
9. **Next Pair Gain System ID**—After entering the final Pair Count Record for this Pair Gain System ID, enter pound # when DATU-RT prompts start of pair count to start entering a new Pair Gain System ID and count record.

Reading One Pair Gain System Record

After accessing the DATU with the System password, perform the following steps to Read One Pair Gain System Record (see Figure 3-4).

1. Enter **9** to read or change Pair Gain System parameters. At this time the DATU-RT will announce the available options.
2. Enter **2** to read one Pair Gain System Record.

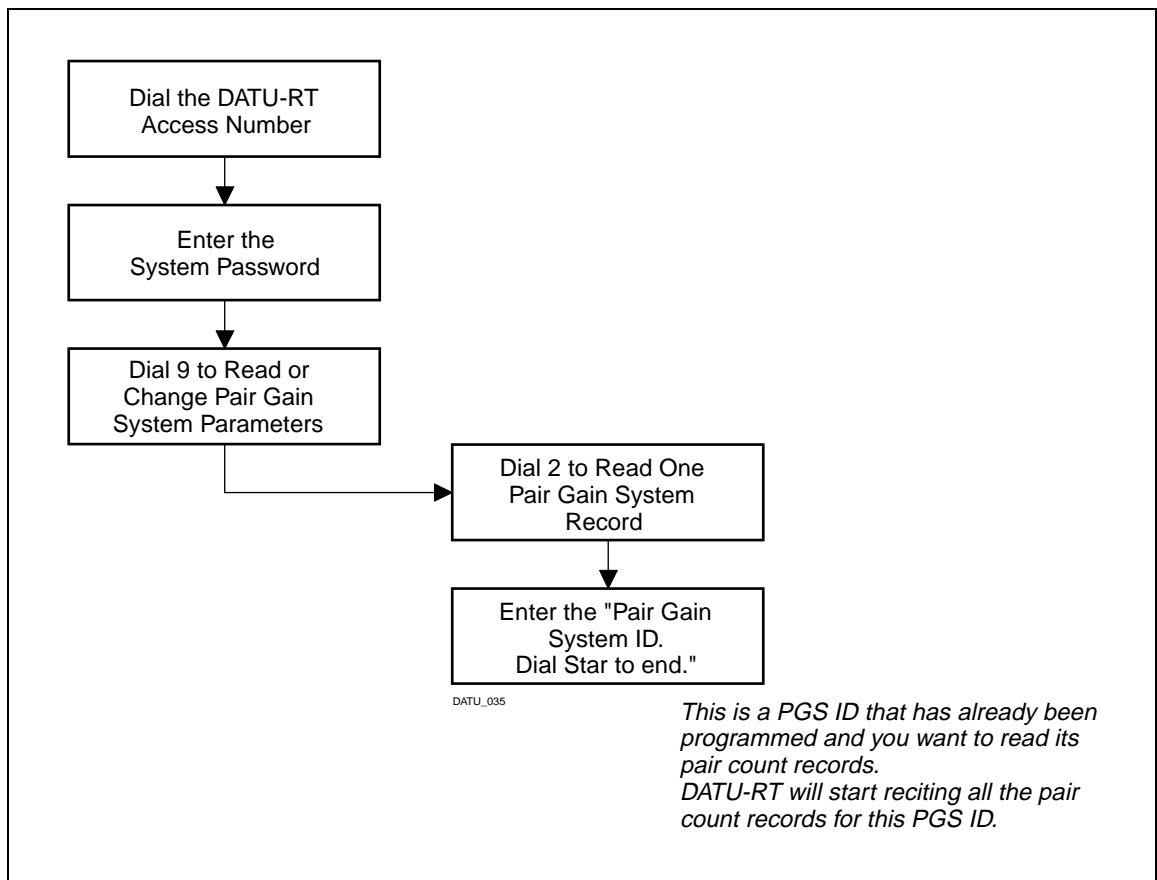

Figure 3-4. Reading One Pair Gain System Record

3. **Pair Gain System ID**—DATU-RT will prompt for the Pair Gain System ID (PGS ID). This entry is the identifier of a Pair Gain System ID that has previously been programmed into the DATU-RT and you wish to read the pair count records (e.g., Pair Gain system 1056 on Elm Street as seen in Figure 3-1 and Figure 3-2). If unsure of the exact PGS ID to be entered, escape by entering pound (#) and read all Pair Gain System Records (see Figure 3-5). Enter star (*) to end this portion of the entry.
4. **Pair Count Records**—DATU-RT will recite the entire Pair Gain System Record for this PGS ID.

Reading All Pair Gain System Records

After accessing the DATU with the System password, perform the following steps to read all Pair Gain System Records (see Figure 3-5).

1. Enter **9** to read or change Pair Gain System parameters. At this time the DATU-RT will announce the available options.
2. Enter **3** to read all Pair Gain System Records.
3. **Reading Records**—DATU-RT will recite the entries of all Pair System Records previously programmed.

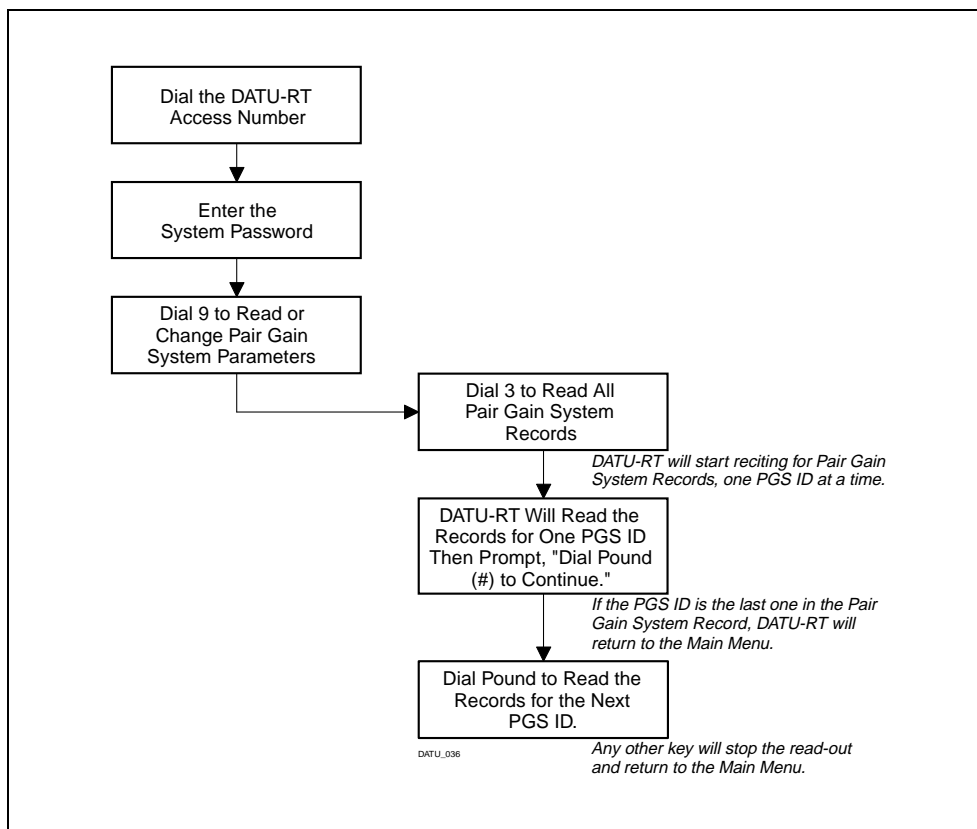

Figure 3-5. Reading All Pair Gain System Records

Deleting One Pair Gain System Record

After accessing the DATU with the System password, perform the following steps to delete one Pair Gain System Record (see Figure 3-6).

1. Enter **9** to read or change Pair Gain System parameters. At this time the DATU-RT will announce the available options.
2. Enter **4** to delete one Pair Gain System Record.
3. **Pair Gain System ID**—DATU-RT will prompt for the Pair System ID to be deleted.
4. **Confirmation**—DATU-RT will recite the Pair Gain System Record as it was programmed, then prompt you to dial pound (**#**) to delete one Pair Gain System Record. Enter star (*****) to end this portion of the entry.

Note: By entering a pound (#) at this point, the Pair Gain System Record just recited will be deleted. Any other key will cancel the deletion and return the programmer to the Main Menu.

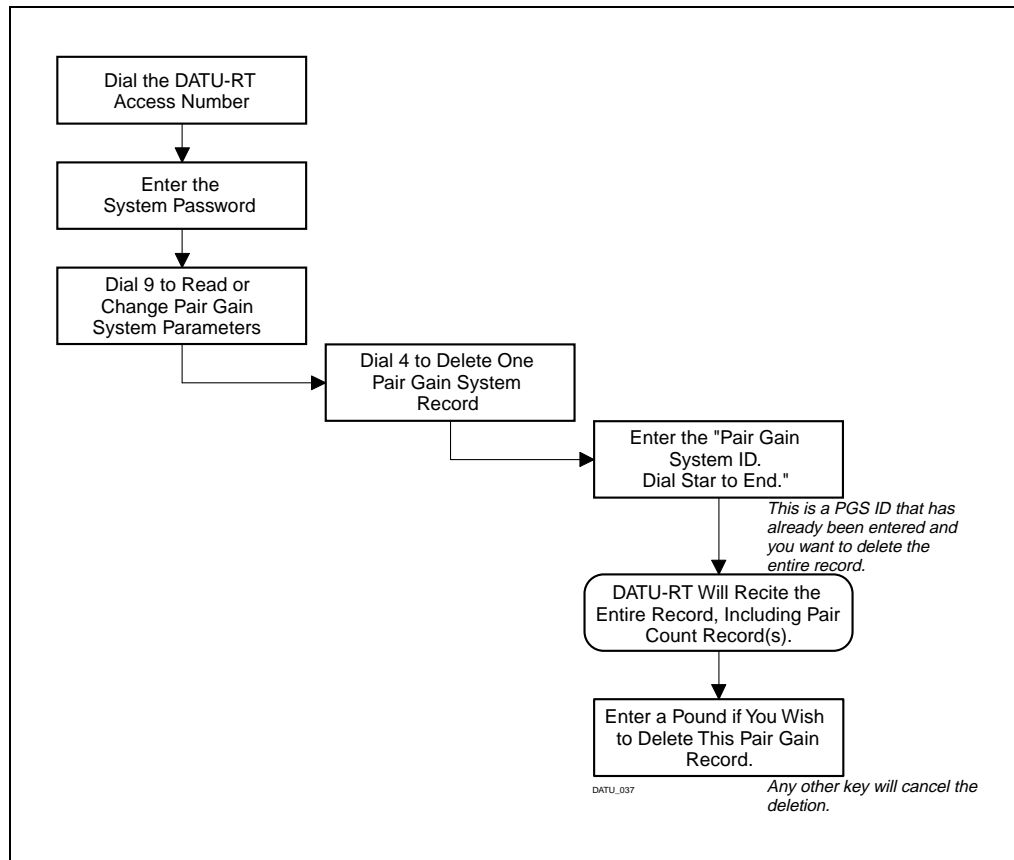

Figure 3-6. Deleting a Pair Gain System Record

Deleting All Pair Gain System Record(s)

After accessing the DATU with the System password, perform the following steps to delete all Pair Gain System Record(s) (see Figure 3-7).

1. Enter **9** to read or change Pair Gain System parameters. At this time the DATU-RT will announce the available options.

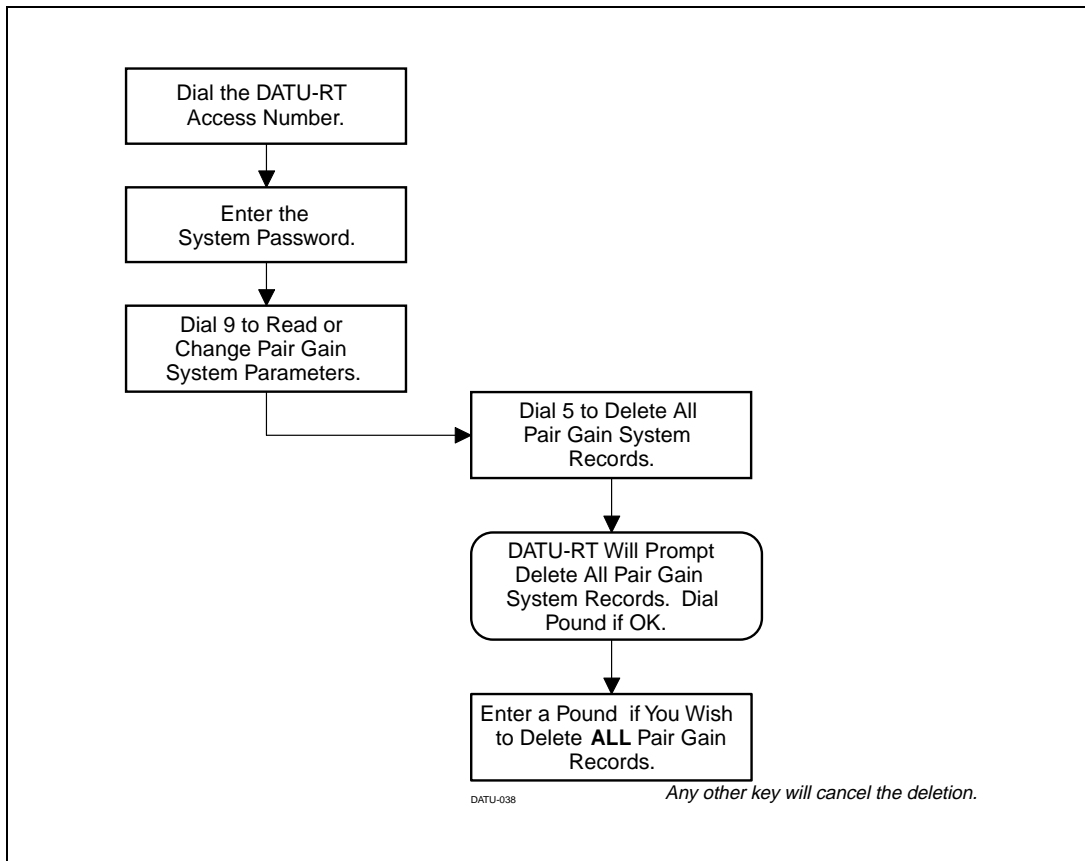

Figure 3-7. Deleting All Pair Gain System Records



CAUTION:

Completing this procedure will delete ALL Pair Gain System Records previously programmed into the DATU-RT.

2. Enter **5** to delete all Pair Gain System Records.
3. **Confirmation**—DATU-RT will read back the selection and prompt for a pound (#) if **OK**.

Adding Pair Count Record(s) (To Previously Entered Pair Gain Systems)

After accessing the DATU with the System password, perform the following steps to add new Pair Count Record(s) to an existing Pair Gain System ID (see Figure 3-8).

1. Enter **9** to read or change Pair Gain System parameters. The DATU-RT announces the available options.
2. Enter **6** to add a Pair Count Record.

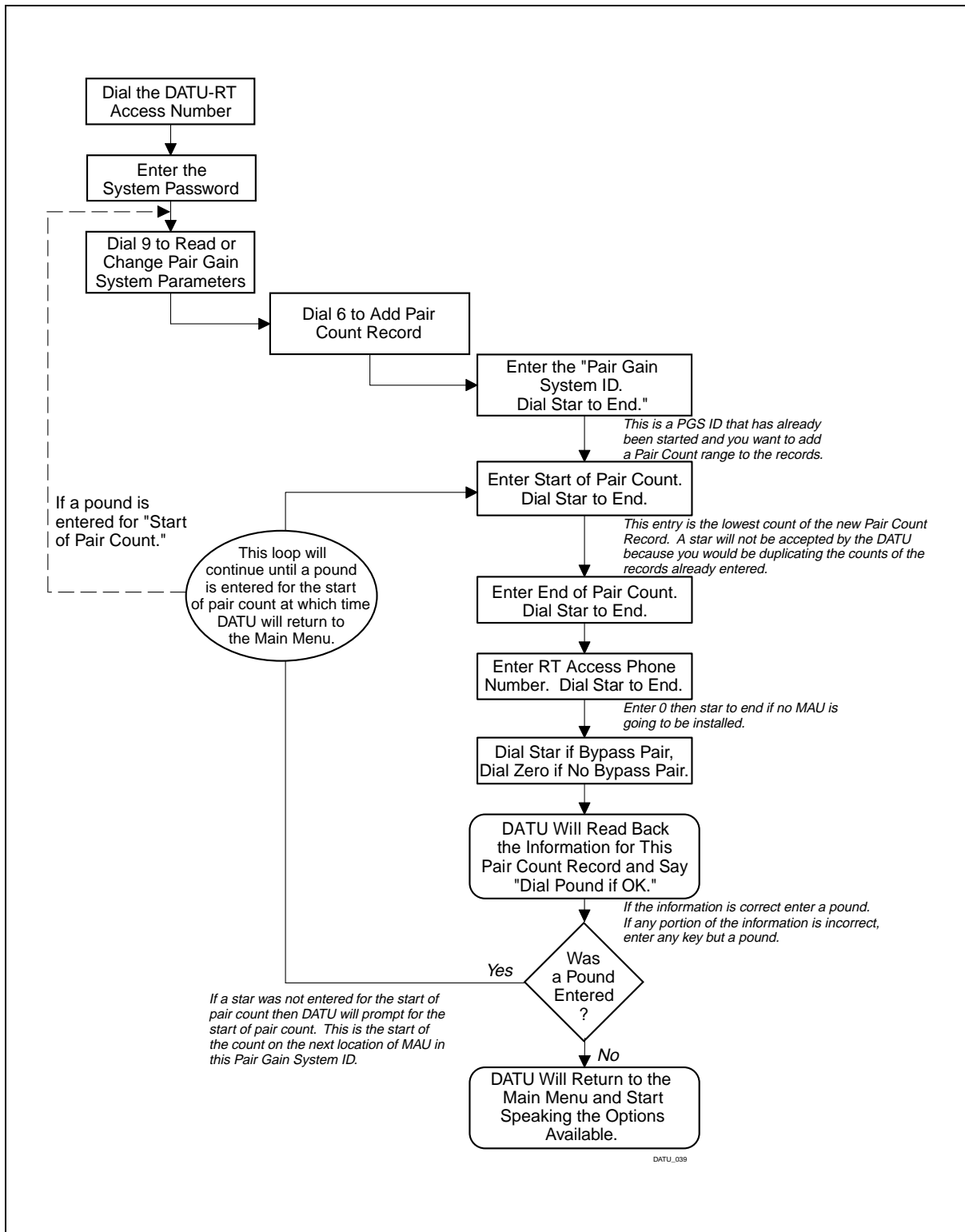

Figure 3-8. Adding Pair Counts to a Pair Gain System Record

Important: DATU will not accept a star * in this entry because * represents 0-9999 (which, by definition, overlaps counts of any existing pair count records).

3. **Pair Gain System ID**—DATU-RT prompts for the Pair Gain System ID (PGS ID). This entry is the identifier of a Pair Gain System ID that has previously been programmed into the DATU-RT (e.g., Pair Gain System 1056 on Elm Street as seen in Figure 3-1). If unsure of exact PGS ID to be entered, escape by entering pound (#) and then read all Pair Gain System Records (see Table 3-5). Dial star (*) to end this portion of the entry.

4. **Start of Pair Count**—DATU-RT prompts for the start of pair count. This is the lowest cable pair count (1 to 4 digits) of the new Pair Count Record to be programmed into the DATU-RT. Dial star (*) to end this portion of the entry.

5. **End of Pair Count**—DATU-RT prompts for the end of pair count. This is the highest cable pair count (1 to 4 digits) in this Pair Count Record for this metallic test path. (See example below.) Dial star (*) to end this portion of the entry.

Example: Pair Gain System 1056 has new counts 1501 through 1700 in the 52nd Street Cabinet (1501 should be entered as the Start Of Pair Count and 1700 should be entered as the End of Pair Count for this new Pair Count Record [see Figure 3-2]).

6. **Bypass Pair**—DATU-RT prompts for the availability of the bypass pair. If there is a bypass pair to the remote site it should be programmed into the DATU-RT by entering a star (*). If there is no bypass pair to the remote site enter a 0.

Option Note: A MAU may be placed in a remote site that is served by a DC test pair to allow for metallic conditioning of the customer's drop without having to consider the test pair's length to the serving CO. By programming the presence of the test pair into the DATU-RT the craftsperson has the option of which to use. The DATU-RT will condition with the MAU unless told to do otherwise, and will prompt the craft to enter star (*) to use the bypass pair if the DATU-RT cannot establish contact with the MAU.

7. **RT Access Phone Number**—DATU-RT prompts **ENTER RT ACCESS PHONE NUMBER, DIAL STAR (*) TO END**. This is the telephone number of the POTS channel unit assigned to the MAU at this location. The phone number may be 1 to 11 digits long but will more than likely be a standard 7 digits. If no MAU is installed enter 0 for the RT access phone number. Dial Star (*) to end this portion of the entry.

8. **Confirmation**—DATU-RT reads back the entries made for this PGS ID, then prompts **DIAL POUND (#) If OK**. If anything is incorrect, or for any other reason the PGS ID is not desired, simply hit any key except pound (#) to cancel and return to the Main System Menu. If, however, all the information is correct, confirm it with a pound (#). After saving the Pair Count Record (and prompting OK) the DATU-RT begins accepting data for the next pair count record for this Pair Gain System ID by asking for the next start of pair count.

9. **Last Entry**—After the last Pair Count Record has been entered for this Pair Gain System ID enter pound (#) when DATU-RT prompts start of pair count. DATU-RT will return to the Main System Menu and list the options available.

Deleting One Pair Count Record

After accessing the DATU with the System password, perform the following steps to delete one Pair Count Record from an existing Pair Gain System Record (see Figure 3-9).

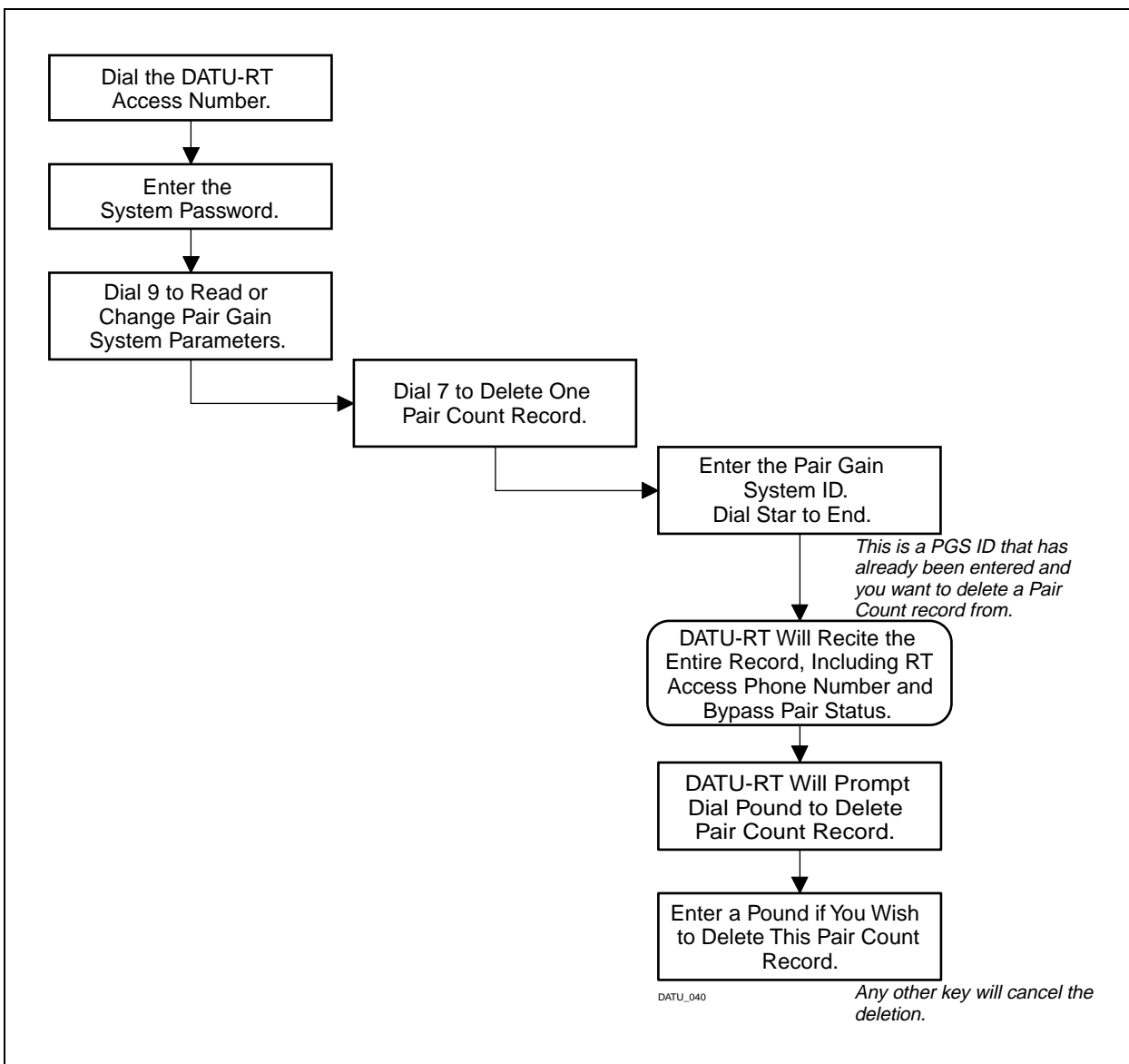

Figure 3-9. Deleting One Pair Count Record

-
1. Enter **9** to read or change Pair Gain System Parameters. The DATU-RT announces the available options.
 2. Enter **7** to delete one Pair Count Record.
 3. **Pair Gain System ID**—DATU-RT prompts for the Pair Gain System ID (PGS ID). This entry is the identifier of a Pair Gain System ID previously programmed into the DATU-RT that you wish to delete a Pair Count Record from. Dial star (*) to end this portion of the entry.
 4. **Pair Count**—DATU-RT will prompt you to enter pair number. Dial star (*) to end. This is any pair number falling in the pair count record to be deleted.
 5. **Confirmation**—DATU-RT recites the Pair Count Record that contains the pair number entered in the previous step, including RT access phone number and the presence or absence of the bypass pair. At the end of the Pair Count Record DATU-RT will prompt **DIAL POUND (#) TO DELETE PAIR COUNT RECORD**. Dial pound (#) to delete record, any other key to cancel deletion.

Setting the RT System Baud Rate

After accessing the DATU with the System password, perform the following steps to set RT System Baud Rate (see Figure 3-10).

1. Enter **9** to read or change Pair Gain System parameters. The DATU-RT announces the available options.
2. Enter **8** to set RT System Baud Rate.
3. **Baud Rate**—This is the speed of communications the DATU-RT modem uses to communicate with all the MAU modems of this CO.
4. **Entry**—DATU-RT prompts **PLEASE ENTER BAUD RATE**. Enter **3 0 0** or **1 2 0 0** for 300 Baud and 1200 Baud respectively.
5. **Confirmation**—DATU-RT reads back the Baud rate and asks for a pound (#) if this is OK. The prompts are **Baud Rate 0 3 0 0. DIAL POUND (#) IF OK** or **Baud Rate 1 2 0 0. DIAL POUND (#) IF OK**. Dial pound (#) to confirm or any other key to abort the entry.

Note: In situations where the factory default of 1200 Baud is not reliable (e.g., Step-By-Step COs), it is advisable to set the DATU-RT for 300 Baud.

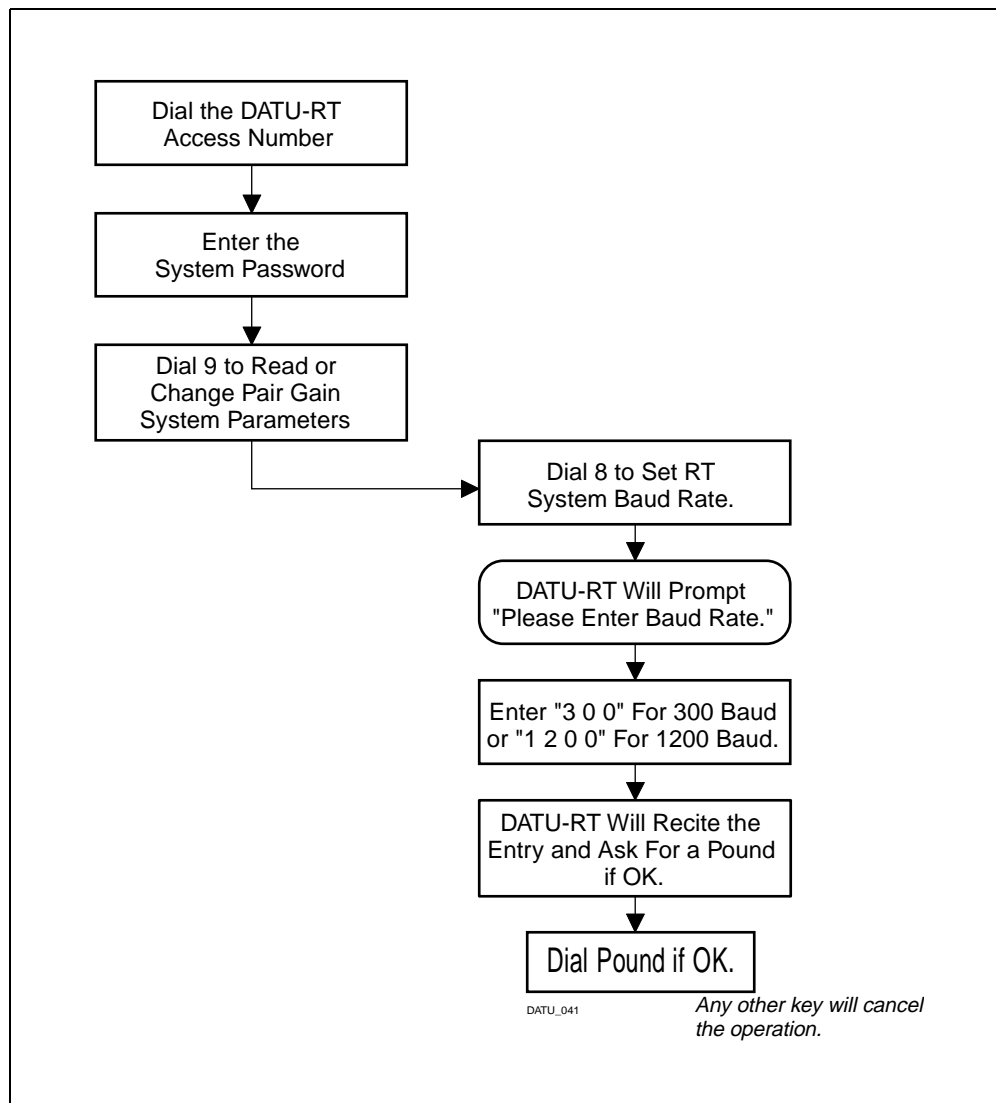

Figure 3-10. Setting RT System Baud Rate

Time Outs and Disconnects

The automatic time outs and disconnects provided by DATU-RT are described below.

Dialing a System or User Password

The first digit must be dialed within 7 seconds after ring trip or the DATU-RT will disconnect.

The elapsed time between digits dialed must be less than 7 seconds or the DATU-RT will disconnect.

The DATU-RT will disconnect after 7 seconds with no keys dialed or after the 16th incorrect digit, if incorrect dial codes are attempted.

User Mode

If the first digit of the subscriber line number is not dialed within 7 seconds or if more than 7 seconds elapse between digits, the DATU-RT will provide voice announcements prompting for the subscriber number.

After accessing a subscriber line, DATU-RT will announce **AUDIO MONITOR** and apply that function for 15 seconds. After this time period DATU-RT will announce the line condition functions that are available to the technician.

Unless the Hold Test feature has been activated, the subscriber line under test will be released when the technician goes on-hook.

A double pound (**##**) dialed at any time will cause the DATU-RT to disconnect. The pound (**#**) key must be pressed twice within one second to distinguish this function from the new subscriber line function, which is a single **#**.

System Mode

A 440 Hz tone is provided in the Main System Menu while the DATU-RT is waiting for programming commands. After 7 seconds of tone, the DATU-RT recites all the Main Menu options.

After 10 minutes without keypad entry from the caller (in System Mode), the DATU-RT will disconnect.

Selecting Line Preparation Functions

4

Contents

Description	4-4
Normal (Separate) Line Access—Local Metallic Loops	4-4
■ DATU-RT Access	4-5
■ Subscriber Line Access	4-5
■ Subscriber Line Status	4-6
Menu Item Selection	4-7
■ Announce Main Menu (Keypad Digit 1)	4-8
■ Audio Monitor (Keypad Digit 2)	4-8
■ Short-to-Ground (Keypad Digit 3)	4-9
■ High-Level Tone (Keypad Digit 4)	4-10
■ Low-Level Tone (Keypad Digit 5)	4-11
■ Open Subscriber Line (Keypad Digit 6)	4-11
■ Short Subscriber Line (Keypad Digit 7)	4-11
■ Permanent Signal Release (Keypad Digit 9)	4-12
■ New Subscriber Line (Keypad Digit #)	4-12
■ Hold Test (Keypad Digit *[n])	4-13

Single-Line Access—Local Metallic Loops **4-13**

- DATU-RT Access 4-14
- Subscriber Line Access 4-14
- Menu Item Selection 4-15
- Announce Main Menu (Keypad Digit 1) 4-16
- Short-to-Ground (Keypad Digit 3) 4-16
- High-Level Tone (Keypad Digit 4) 4-17
- Open Subscriber Line (Keypad Digit 6) 4-17
- Short Subscriber Line (Keypad Digit 7) 4-18

Normal (Separate) Line Access—Carrier System Lines **4-18**

- DATU-RT Access 4-18
- Subscriber Line Access 4-19
- Subscriber Line Status 4-19
- Remote Terminal (RT) Access 4-20
- Alphanumeric Pair Gain System ID Entry 4-21
- Menu Item Selection 4-22
- Announce Main Menu (Keypad Digit 1) 4-23
- Audio Monitor (Keypad Digit 2) 4-24
- Short-to-Ground (Keypad Digit 3) 4-24
- High-Level Tone (Keypad Digit 4) 4-25
- Low-Level Tone (Keypad Digit 5) 4-26
- Open Subscriber Line (Keypad Digit 6) 4-26
- Short Subscriber Line (Keypad Digit 7) 4-26
- Permanent Signal Release (Keypad Digit 9) 4-27
- New Subscriber Line (Keypad Digit #) 4-27
- Hold Test (Keypad Digit *[n]) 4-28

Single-Line Access—Carrier System Lines **4-28**

- DATU-RT Access 4-29
- Subscriber Line Access 4-29
- Remote Terminal (RT) Access 4-30

■ Alphanumeric Pair Gain System ID Entry	4-30
■ Menu Item Selection	4-31
■ Announce Main Menu (Keypad Digit 1)	4-32
■ Short-to-Ground (Keypad Digit 3)	4-32
■ High-Level Tone (Keypad Digit 4)	4-33
■ Open Subscriber Line (Keypad Digit 6)	4-33
■ Short Subscriber Line (Keypad Digit 7)	4-34
Setting the Hold Time	4-34

Description

The DATU-RT provides technicians in both CO and field environments with the ability to electrically condition any subscriber line served from the CO. The DATU-RT is able to access and condition lines contained within the metallic loop plant as well as those served by loop carrier systems. Lines served by Loop Carrier Systems may be conditioned at the Remote Terminal (RT) or at the CO via the DC Bypass pair. Those contained within the metallic loop plant are conditioned at the CO.

The DATU-RT is accessed and controlled through a dedicated POTS line interface using a standard butt set or other telephone instrument with DTMF signaling capability. The DATU-RT responds to standard DTMF tones provided by the technician using the telephone keypad and provides voice messages which guide the technician through the DATU-RT functions.

This Section describes DATU-RT line conditioning features and their applications in troubleshooting suspected line faults.

Subsections within this section contain discussions of user procedures for conditioning subscriber lines contained within the loop plant as well as those served by carrier systems.

These procedures are organized as follows:

- Normal (Separate) Line Access of Local CO Served Lines - Local Metallic Loops.
- Single-Line Access of Local CO Served Lines - Local Metallic Loops.
- Normal (Separate) Line Access of Carrier System Lines.
- Single-Line Access of Carrier System Lines.

The appropriate normal (separate line) procedure is recommended whenever possible as it affords increased flexibility in conditioning and testing the line. If a separate line is not available, refer to the appropriate Single-Line Access procedure.

Normal (Separate) Line Access—Local Metallic Loops

The DATU-RT may be accessed using the line that is to be conditioned or a separate line. This section describes the preferred method of separate-line access of a metallic loop served from the CO.

DATU-RT Access

To access the DATU-RT:

1. Dial the telephone number assigned to the DATU-RT.
2. Wait for uninterrupted 440 Hz DATU-RT dial tone indicating DATU-RT has answered and is ready for password entry.
3. Enter your password using the telephone keypad. Note that DATU-RT dial tone is removed upon entry of the first password digit.

The first digit of your password must be entered within 7 seconds after DATU-RT dial tone is heard. If more than 7 seconds elapses before entry of the first digit or between subsequent digits, the DATU-RT disconnects and releases the line.

4. DATU-RT dial tone is restored upon successful entry of a valid password.

DATU-RT disconnects and releases the line 7 seconds after the last key depression if an invalid or incomplete password is entered.

The voice message **ERROR, BAD NO-TEST TRUNK** indicates the DATU-RT has detected an abnormal condition on the NTT. Line conditioning functions will not be available until the NTT problem is corrected.

Subscriber Line Access

To access the subscriber's line:

Note: DATU-RT dial tone is removed upon entry of first digit.

1. Dial the subscriber's telephone number.
2. If the first digit of the subscriber's telephone number is not entered within 7 seconds of DATU-RT dial tone, the voice prompt **DIAL SUBSCRIBER LINE NUMBER** is issued. If no digits have been entered after 60 seconds of DATU-RT dial tone, DATU-RT disconnects and releases the line.

Unless the DATU-RT is set to 10-digit dialing mode, entry of a telephone number not served by the CO, causes the DATU-RT to issue the following voice message **INVALID PREFIX. DIAL SUBSCRIBER LINE NUMBER**.

Note: ddd-dddd represents the telephone number of the line under test.

3. If the selected subscriber line is idle, the DATU-RT accesses the line and you will hear the voice message **CONNECTED TO ddd-dddd. OK. AUDIO MONITOR**. You may select a line preparation function anytime after the voice message begins (the line is automatically monitored for 10 seconds).

Note: When set to 10-digit dialing mode, the prompt will be (ddd) ddd-dddd.

4. If the voice message: **CONNECTED TO ddd-dddd. BUSY LINE. AUDIO MONITOR.** is heard, the line is busy. A busy line will be monitored for 10 seconds. Traffic on a busy line will be audible but unintelligible. At the end of the automatic 10 second monitor period DATU-RT will send two 614 Hz tones in rapid succession to indicate the end of the monitor period. On a busy line, the DATU-RT will announce the line preparation functions available immediately following the audio monitor period. You may select an available option or dial # to return to step (2) and select a different subscriber line.
5. A line preparation function may be selected at any time during the 10 second audio monitor period, or after the voice message begins.

Subscriber Line Status

To obtain the status of a subscriber's line:

1. The DATU-RT announces the state of the subscriber line/NTT with one of the following voice messages:

OK - if the line is idle.

BUSY LINE - if the line is busy.

2. Verify the line state reported by the DATU-RT by monitoring the line for audio activity. The DATU-RT automatically provides a 15-second Audio Monitor interval after the line state has been determined. To protect the privacy of the subscriber, conversations are audible but unintelligible.

Features that would be disruptive to a call in progress are not available if the DATU-RT detects a busy line condition. These functions include High-Level Tone, Open Subscriber Line, and Short Subscriber Line. If conversation or data transfer activity is heard on a line that the DATU-RT has reported as idle, do not activate these functions.

3. At the end of the monitoring period, the DATU-RT generates two short bursts of 614 Hz tone to indicate that the Audio Monitor period has ended.

Another function may be selected during the monitor interval. Doing so immediately enables the selected function and cancels the monitor feature.

If no function is selected within the 60 second interval following expiration of the monitor period, the DATU-RT announces it's Main Menu.

Menu Item Selection

DATU-RT functions are presented in a menu format through voice messages. Main Menu functions are announced as follows:

- **DIAL 2 FOR AUDIO MONITOR.**
- **DIAL 33 FOR TIP/RING SHORT TO GROUND.**
- **DIAL 37 FOR RING GROUND.**
- **DIAL 38 FOR TIP GROUND.**
- **DIAL 44 FOR TIP/RING HIGH LEVEL TONE.**
- **Dial 47 for RING HIGH LEVEL TONE.**
- **DIAL 48 FOR TIP HIGH LEVEL TONE.**
- **DIAL 5 FOR LOW-LEVEL TONE.**
- **DIAL 6 TO OPEN SUBSCRIBER LINE.**
- **DIAL 7 TO SHORT SUBSCRIBER LINE.**
- **DIAL STAR (*) TO KEEP TEST AFTER DISCONNECT.**
- **DIAL POUND (#) FOR NEW SUBSCRIBER LINE.**

If two or more options are associated with the selected function, a corresponding submenu is announced after the menu item is selected. Table 4-1 presents a listing of both main and submenu functions with their assigned keypad digits. Note the correlation between the names assigned to certain Main Menu functions and the standard alphabetical arrangement of the telephone keypad.

Line preparation functions are selectable as soon as the DATU-RT has determined the state of the subscriber line. If the line is idle, all functions are available. If the line is busy, the set of available functions includes only those that are not disruptive to calls-in-progress (see Subscriber Line Status). Functions may be activated in any sequence, however, only one function may be active at a time. Selection of any menu item cancels the previously-active function. If an incorrect or invalid entry is made, the current function (if any) remains in effect.

An Access Timeout feature limits the time during which line preparation functions are sustained or allowed to remain active.

The access time out interval is preset at the factory to allow the selected function to remain active for up to 10 minutes. The factory setting also allows extension of this interval by simply selecting the same function again or, if desired, selecting a new function. The parameters associated with the Access Time Out feature are programmable and accessible only by the DATU-RT Administrator.

Table 4-1. DATU-RT Separate-Line Access Main Menu

Main Item/Function	Main Menu Key	SubMenu Key
Announce Main Menu	1	
Audio Monitor	2 (ABC)	
Short to Ground (Earth)	3 (DEF)	3
Tip and Ring to Ground		
Ring Ground		7 (PRS)
Tip Ground		8 (TUV)
High-Level Tone	4 (GHI)	4
Tip and Ring Tone		
Ring Tone with Tip Grounded		7 (PRS)
Tip Tone with Ring Grounded		8 (TUV)
Low-Level Tone	5 (JKL)	
Open Subscriber Line	6 (MNO)	
Short Subscriber Line	7 (PRS)	
Permanent Signal Release	9	
New Subscriber Line	#	
Hold Test	*[n] ¹	
Forced Disconnect	##	
Notes:		
1. n represents time in minutes. Refer to description of Hold function.		
2. Highlighted letters represent Key codes to functions.		

Announce Main Menu (Keypad Digit 1)

Selection of this function causes the DATU-RT to announce it's Main Menu. If selected while in a submenu, DATU-RT announces **ERROR** followed by the Main Menu.

1. Momentarily press **1** on the telephone keypad.
2. The DATU-RT announces it's Main Menu.

Audio Monitor (Keypad Digit 2)

The Audio Monitor function provides a means by which the idle or busy line status reported by the DATU-RT may be verified. To protect the privacy of the subscriber, conversation is audible but unintelligible.

1. Momentarily press **2** on the telephone keypad.
2. The DATU-RT announces **AUDIO MONITOR**.

-
3. Monitor the line as required.

Audio Monitor is automatically disabled at regular intervals to insure that the DATU-RT is able to detect DTMF tones if an exceptionally strong audio signal is present. This occurs at regular six-second intervals and is of approximately two seconds duration.

Short-to-Ground (Keypad Digit 3)

This function is not available if the DATU-RT has determined that the line is busy. The DATU-RT announces the following error message if an attempt is made to invoke this function on a busy line: **ERROR - BUSY LINE**.

The Short-to-Ground function is used to connect the Tip, Ring or both leads to Ground potential. If only a single lead (Tip or Ring) is selected, the opposite lead is unterminated.

1. Momentarily press **3** on the telephone keypad.
2. The DATU-RT issues the following submenu prompt:
 - a. **DIAL 3 FOR TIP-RING SHORT-TO-GROUND.**
 - b. **DIAL 7 FOR RING GROUND.**
 - c. **DIAL 8 FOR TIP GROUND.**
3. Momentarily press the key corresponding to the desired subfunction.
4. The DATU-RT identifies the selected subfunction with one of the following voice messages:

TIP-RING SHORT TO GROUND - if submenu item **3** selected.

RING GROUND - if submenu item **7** selected.

TIP GROUND - if submenu item **8** selected.

The selected function remains in effect until another function is selected, the access timeout interval is exceeded or the subscriber line is released.

The DATU-RT does not remain in the Short-to-Ground submenu after the subfunction is selected. To select another Short-to-Ground subfunction, both Main and submenu selections must be made.

High-Level Tone (Keypad Digit 4)

This function is not available if the DATU-RT has determined that the line is busy. The DATU-RT announces the following error message if an attempt is made to invoke this function on a busy line: **ERROR - BUSY LINE**.

This function places a 577 Hz high-level (+22 dBm) interrupted tone bursts on the Tip lead, Ring lead or both. If a single lead is selected, the opposite lead is grounded. This function is typically used for the purpose of conductor or pair identification.

1. Momentarily press **4** on the telephone keypad.
2. The DATU-RT issues the following submenu prompt:
 - a. **DIAL 4 FOR TIP-RING HIGH-LEVEL TONE.**
 - b. **DIAL 7 FOR RING HIGH-LEVEL TONE.**
 - c. **DIAL 8 FOR TIP HIGH-LEVEL TONE.**
3. Momentarily press the key corresponding to the desired subfunction.
4. The DATU-RT identifies the selected subfunction with one of the following voice messages:

TIP-RING HIGH-LEVEL TONE - if submenu item **4** selected.

RING HIGH-LEVEL TONE - if submenu item **7** selected.

TIP HIGH-LEVEL - if submenu item **8** selected.

The selected function remains in effect until another function is selected, the access timeout interval is exceeded or the subscriber line is released.

The DATU-RT does not remain in the High-Level Tone submenu after the subfunction is selected. To select another High-Level Tone subfunction, both Main and submenu selections must be made.

Low-Level Tone (Keypad Digit 5)

This function places a 577 Hz low-level (-12 dBm) interrupted tone bursts on both the Tip and Ring leads. Because the tone signal is longitudinal, use of this function does not disrupt traffic on a busy line. Tone bursts can be heard only on a telephone instrument connected between Tip or Ring and Ground. This function is typically used for the purpose of conductor or pair identification on a busy subscriber line.

1. Momentarily press **5** on the telephone keypad.
2. The DATU-RT responds with the voice message **LOW-LEVEL TONE**.

The selected function remains in effect until another function is selected, the access timeout interval is exceeded or the subscriber line is released.

Open Subscriber Line (Keypad Digit 6)

This function is not available if the DATU-RT has determined that the line is busy. The DATU-RT announces **BUSY LINE**, if an attempt is made to invoke this function on a busy line.

The Open Subscriber Line function removes Battery and Ground potentials from the subscriber's Tip and Ring leads.

1. Momentarily press **6** on the telephone keypad.
2. The DATU-RT responds with the voice message **OPEN LINE**.

The selected function remains in effect until another function is selected, the access timeout interval is exceeded or the subscriber line is released.

Short Subscriber Line (Keypad Digit 7)

This function is not available if the DATU-RT has determined that the line is busy. The DATU-RT announces the following error message if an attempt is made to invoke this function on a busy line: **ERROR - BUSY LINE**.

The Short Subscriber Line function provides an electrical short across the subscriber's Tip and Ring leads.

1. Momentarily press **7** on the telephone keypad.
2. The DATU-RT responds with the voice message **SHORT LINE**.

The selected function remains in effect until another function is selected, the access timeout interval is exceeded or the subscriber line is released.

Permanent Signal Release (Keypad Digit 9)

This function is not available unless specifically enabled by the DATU-RT administrator. Unless enabled, any attempt to use this function results in the error message **ERROR - PERMANENT SIGNAL RELEASE DISABLED**.

Permanent Signal Release will function only on a line that the DATU-RT has identified as busy. An attempt to use this function on an idle line results in the error message **ERROR - IDLE LINE**.

The Permanent Signal Release function causes the removal of Battery and Ground potentials from a permanent signal line served by a step-by-step switch. This function is typically used to clear a busy condition resulting from a line fault so that normal line tests may be performed.

1. Momentarily press **9** on the telephone keypad.
2. The DATU-RT responds with the voice message **PERMANENT SIGNAL RELEASE**.
3. After executing the required sequence of operations, the DATU-RT tests the subscriber line to determine whether the busy condition has been cleared. The result of this test is then announced as follows:

OK - if the line is idle.

BUSY LINE - if the line is busy.

New Subscriber Line (Keypad Digit #)

This function releases the currently-held subscriber line so that another subscriber line may be accessed.

1. Momentarily press the **#** key on the telephone keypad.
2. The DATU-RT responds with DATU-RT dial tone.
3. Enter the new subscriber line number as done previously in the Subscriber Line Access section.

The voice message **TRUNK DISCONNECT ERROR** indicates the DATU-RT has detected an abnormal condition on the NTT. Line conditioning functions will not be available until the NTT problem is corrected.

Hold Test (Keypad Digit *[n])

The Hold Test feature provides a means by which a line condition asserted by the DATU-RT is maintained for a specified time interval after disconnecting from the DATU-RT. The duration of the hold test interval is entered through the telephone keypad and is specified in minutes. Any interval may be entered, however, the DATU-RT will not maintain a line condition longer than the access timeout interval. The programmed function is automatically cancelled by the DATU-RT when the specified time interval or, if of a shorter duration, the access timeout interval has elapsed.

1. Momentarily press the star (*) key on the telephone keypad.
2. The DATU-RT responds with the following voice prompt:

DIAL NUMBER OF MINUTES - if access timeout interval is 10 minutes or less.

DIAL 2 DIGITS FOR NUMBER OF MINUTES - if access timeout interval is more than 10 minutes.

3. Enter the desired hold time via the telephone keypad.

If the access timeout interval is set for 10 minutes or less, this must be a single-digit entry. Entry of a **0** is interpreted as an entry of 10 minutes.

If the access timeout interval is set for greater than 10 minutes, the Hold Time interval must be entered as a two-key sequence. This means that a leading **0** must be entered for a hold time interval of 9 minutes or less.

If no hold time entry is made, a default interval equal to one-half the access timeout interval is used.

4. The DATU-RT responds with the voice prompt **PLEASE HANG UP**.
5. The selected line conditioning function remains active for the specified Hold Time interval or, if of a shorter duration, the access timeout interval.

Single-Line Access—Local Metallic Loops

This subsection describes the methods and procedures associated with single-line access of a metallic loop served from the CO. The procedures contained in this section should be used when it is necessary to access the DATU-RT on the same line that is to be conditioned.

DATU-RT Access

To access the DATU-RT:

1. Dial the telephone number assigned to the DATU-RT.
2. Wait for an uninterrupted 440 Hz DATU-RT dial tone indicating DATU-RT has answered and is ready for password entry.
3. Enter your password using the telephone keypad. The DATU-RT dial tone is removed upon entry of the first password digit.

The first digit of your password must be entered within 7 seconds after DATU-RT dial tone is heard. If more than 7 seconds elapses before entry of the first digit or between subsequent digits, the DATU-RT disconnects and releases the line.

4. DATU-RT dial tone is restored upon successful entry of a valid password.

DATU-RT disconnects and releases the line 7 seconds after the last key depression if an invalid or incomplete password is entered.

The voice message **ERROR, BAD NO-TEST TRUNK**, indicates the DATU-RT has detected an abnormal condition on the NTT. Line conditioning functions will not be available until the NTT problem is corrected.

Subscriber Line Access

To access the subscriber's line:

1. Dial * followed by the subscriber's telephone number.
2. If the first digit is not entered within 7 seconds of DATU-RT dial tone, the voice prompt **DIAL SUBSCRIBER LINE NUMBER** is issued. If no digits have been entered after 60 seconds of DATU-RT dial tone, the DATU-RT disconnects and releases the line.

Unless the DATU-RT is set to 10-digit dialing mode, entry of a telephone number not served by the CO causes the DATU-RT to issue the voice message: **INVALID PREFIX. DIAL SUBSCRIBER LINE NUMBER**.

The absence of error messages indicates that the DATU-RT has accepted the subscriber's telephone number.

Note: The DATU-RT dial tone is removed upon entry of the first digit.

Menu Item Selection

DATU-RT functions are presented in a menu format through voice messages. Main Menu functions are announced as follows:

- **DIAL 33 FOR TIP-RING SHORT-TO-GROUND.**
- **DIAL 37 FOR RING GROUND.**
- **DIAL 38 FOR TIP GROUND.**
- **DIAL 44 FOR TIP-RING HIGH LEVEL TONE.**
- **DIAL 47 FOR RING HIGH LEVEL TONE.**
- **DIAL 48 FOR TIP HIGH LEVEL TONE.**
- **DIAL 6 TO OPEN SUBSCRIBER LINE.**
- **DIAL 7 TO SHORT SUBSCRIBER LINE.**
- **DIAL POUND (#) FOR NEW SUBSCRIBER LINE.**

If two or more options are associated with the selected function, a corresponding submenu is announced after the Main Menu item is selected. Table 4-2 presents a listing of both Main and submenu functions with their assigned keypad digits. Note the correlation between the names assigned to certain Main Menu functions and the standard alphabetical arrangement of the telephone keypad.

EXAMPLE: Short Ring-to-Ground (Earth)—3 has the letters E for Earth, 7 has the letter R for Ring. Hence, 3 and 7 = Grounded Ring.

Table 4-2. DATU-RT Single-Line Access Menu Items

Main Item/Function		Main Menu Key	Submenu Key
Announcing Main Menu		1	
Short to Ground (Earth)		3 (DEF)	3
	Tip and Ring-to-Ground		
	Ring-to-Ground		7 (PRS)
	Tip-to-Ground		8 (TUV)
High-Level Tone		4 (GHI)	4
	Tip and Ring Tone		
	Ring Tone with Tip Grounded		7 (PRS)
	Tip Tone with Ring Grounded		8 (TUV)
Open Subscriber Line		6 (MNO)	
Short Subscriber Line		7 (PRS)	

The following explains the selection and use of the functions available in the Single-Line Access mode.

Announce Main Menu (Keypad Digit 1)

Selection of this function causes the DATU-RT to announce its Main Menu. If selected while in a submenu, DATU-RT announces **ERROR** followed by the Main Menu.

1. Momentarily press **1** on the telephone keypad.
2. The DATU-RT announces its Main Menu.

Short-to-Ground (Keypad Digit 3)

The Short-to-Ground function is used to connect the Tip, Ring or both leads to Ground potential. If only a single lead (Tip or Ring) is selected, the opposite lead is unterminated.

1. Momentarily press **3** on the telephone keypad.
2. The DATU-RT issues the following submenu prompt:
 - a. **DIAL 3 FOR TIP-RING SHORT-TO-GROUND.**
 - b. **DIAL 7 FOR RING GROUND.**
 - c. **DIAL 8 FOR TIP GROUND.**
3. Momentarily press the key corresponding to the desired subfunction.
4. The DATU-RT identifies the selected sub-function with one of the following voice messages:

TIP-RING SHORT TO GROUND - if submenu item **3** selected.

RING GROUND - if submenu item **7** selected.

TIP GROUND - if submenu item **8** selected.

5. When prompted, enter the desired hold time interval and hang up (for detailed instructions, refer to Setting the Hold Time).

High-Level Tone (Keypad Digit 4)

This function places a 577 Hz high-level (+22 dBm) interrupted tone bursts on the Tip lead, Ring lead or both. If a single lead is selected, the opposite lead is grounded. This function is typically used for the purpose of conductor or pair identification.

1. Momentarily press **4** on the telephone keypad.
2. The DATU-RT issues the following submenu prompt:
 - a. **DIAL 4 FOR TIP-RING HIGH-LEVEL TONE.**
 - b. **DIAL 7 FOR RING HIGH-LEVEL TONE.**
 - c. **DIAL 8 FOR TIP HIGH-LEVEL TONE.**
3. Momentarily press the key corresponding to the desired subfunction.
4. The DATU-RT identifies the selected subfunction with one of the following voice messages:
 - TIP-RING HIGH-LEVEL TONE** - if submenu item **4** selected.
 - RING HIGH-LEVEL TONE** - if submenu item **7** selected.
 - TIP HIGH-LEVEL TONE** - if submenu item **8** selected.
5. When prompted, enter the desired hold time interval and hang up (for detailed instructions, refer to Setting the Hold Time).

Open Subscriber Line (Keypad Digit 6)

The Open Subscriber Line function removes Battery and Ground potentials from the subscriber's Tip and Ring leads.

1. Momentarily press **6** on the telephone keypad.
2. DATU-RT responds with the voice message **OPEN LINE.**
3. When prompted, enter the desired hold time interval and hang up (for detailed instructions, refer to Setting the Hold Time).

Short Subscriber Line (Keypad Digit 7)

The Short Subscriber Line function provides an electrical short across the subscriber's Tip and Ring leads.

1. Momentarily press **7** on the telephone keypad.
2. DATU-RT responds with the voice message **SHORT LINE**.
3. When prompted, enter the desired hold time interval and hang up (for detailed instructions, refer to Setting the Hold Time).

Normal (Separate) Line Access—Carrier System Lines

This subsection describes methods and procedures for separate-line access of a subscriber loop served from a Carrier System Remote Terminal. The procedures contained in this section are applicable only when conditioning a carrier system line using a separate line to access the DATU-RT.

DATU-RT Access

To access the DATU-RT:

1. Dial the telephone number assigned to the DATU-RT.
2. Wait for an uninterrupted 440 Hz DATU-RT dial tone indicating DATU-RT has answered and is ready for password entry.
3. Enter your password using the telephone keypad.

Note: The DATU-RT dial tone is removed upon entry of the first password digit.

The first digit of your password must be entered within 7 seconds after DATU-RT dial tone is heard. If more than 7 seconds elapses before entry of the first digit or between subsequent digits, the DATU-RT disconnects and releases the line.

4. DATU-RT dial tone is restored upon successful entry of a valid password.

DATU-RT disconnects and releases the line 7 seconds after the last key depression if an invalid or incomplete password is entered.

The voice message **ERROR, BAD NO-TEST TRUNK** indicates the DATU-RT has detected an abnormal condition on the NTT. Line conditioning functions will not be available until the NTT problem is corrected.

Subscriber Line Access

Note: The DATU-RT dial tone is removed upon entry of the first digit.

To access the subscriber's line:

1. Dial the subscriber's telephone number.
2. If the first digit of the subscriber's telephone number is not entered within 7 seconds of DATU-RT dial tone, the voice prompt **DIAL SUBSCRIBER LINE NUMBER** is issued. If no digits have been entered after 60 seconds of DATU-RT dial tone, the DATU-RT disconnects and releases the line.

Unless the DATU-RT is set to 10-digit dialing mode, entry of a telephone number not served by the CO causes the DATU-RT to issue the voice message **INVALID PREFIX. DIAL SUBSCRIBER LINE NUMBER**.

3. The DATU-RT announces **ACCESSING** and repeats the subscriber telephone number entered in Step 1.

Subscriber Line Status

To obtain the status of a subscriber's line:

1. The DATU-RT announces the state of the subscriber line/NTT with one of the following voice messages:

PAIR GAIN LINE PROCESSING	- if the line is idle and is a Pair Gain line.
BUSY LINE	- if the line is busy.

If the selected line is busy, the DATU-RT cannot determine whether the line is served by a carrier system. It is, therefore, not possible for the DATU-RT to activate the PGTC and metallicity connect the DC bypass pair at the RT to the subscriber line. Without this metallic connection, the DATU-RT cannot condition the line. In this case, only the audio monitor and low-level tone functions are available to the user. Because it's signal is longitudinal, the low-level tone function is generally not effective when used on a busy Carrier System line.

2. If the line is idle, the DATU-RT attempts to activate the PGTC. The PGTC, in turn, tests the carrier channel and communicates the results to the DATU-RT. These operations require additional time and may result in a delay of up to 30 seconds. After successfully completing these steps, the RT System identifies the carrier channel as follows:

Single-Party Line	- if a single-party channel unit is detected.
Multi-Party Line	- if a multi-party channel unit is detected.
Coin Line	- if a coin channel unit is detected.

If the DATU-RT is unable to activate the PGTC or the PGTC encounters a problem in testing the carrier channel, the DATU-RT issues one of the following voice messages:

BYPASS PAIR BUSY or PGTC FAILURE	- the DC bypass pair is in use, all PGTC test circuits are busy or the PGTC cannot complete carrier system connections.
PAIR GAIN SYSTEM ALARM	- the Carrier System serving the selected line is in a major alarm condition.
CHANNEL NOT AVAILABLE	- channel test results were not provided by the PGTC.
BAD CHANNEL	- channel tests failed - possible bad channel unit.

After a failure in carrier channel tests or in activating the PGTC, the DATU-RT remains in Menu Item Selection mode so that CO personnel may more easily determine the problem. If one of the above error messages is heard, however, the DATU-RT is probably not connected to the line to be tested. Therefore, line conditioning commands will be accepted and confirmed by the DATU-RT but the condition may not necessarily exist on the line anytime after one of the above error messages is heard.

Remote Terminal (RT) Access

To access a remote terminal:

1. After the DATU-RT has successfully accessed the subscriber line and acquired channel test results, the DATU-RT issues the voice prompt **PLEASE ENTER PAIR GAIN SYSTEM ID. DIAL STAR TO END.**
2. Enter Pair Gain System ID using telephone keypad. To condition line from CO using the bypass pair, enter **0***.
3. Use the Alphanumeric Pair Gain System ID Entry section if Pair Gain System ID includes alphabetic or punctuation characters. Otherwise, proceed to Step 4.

If selected, the bypass pair must be in place between the host element of the DATU-RT at the CO and the RT.

4. After the Pair Gain System ID has been successfully entered, the DATU-RT issues the prompt **PLEASE ENTER PAIR NUMBER. DIAL STAR TO END**. Enter the pair number for the subscriber's line using the telephone keypad.
5. The DATU-RT provides verification of the Pair Gain System ID and pair number entry with a voice message. If valid data was entered, the DATU-RT announces **ACCESSING** followed by the RT information previously entered. If the information is not valid or, if the bypass pair was selected, **USING BYPASS PAIR** is heard.
6. Using a dedicated POTS line and modem interface, the CO element of the DATU-RT attempts to establish communication with its slave counterpart at the RT. If this operation is successful, the following is announced: **RT TEST SYSTEM CONNECTED TO ddd-dddd. OK. AUDIO MONITOR**.
7. If unsuccessful in establishing communications with the RT, the RT System announces **FAILURE TO CONNECT**. If a bypass pair is in place between the selected RT and the CO, the DATU-RT additionally prompts **DIAL ONE TO USE BYPASS PAIR, DIAL POUND FOR NEW SUBSCRIBER LINE**.
8. If no bypass pair is available, DATU-RT dial tone is provided so that a new subscriber line number may be entered.

Note: ddd-dddd represents the phone number of the subscriber's line under test.

Note: When set to 10-digit dialing mode, the prompt will be (ddd) ddd-dddd.

Alphanumeric Pair Gain System ID Entry

This section describes the method by which alphabetical letters may be entered using a standard 12-key DTMF keypad.

1. Enter any leading numbers that are part of the Pair Gain System ID in the normal manner.
2. Enter **. This key sequence places the RT system in a special mode in which alpha and certain other non-numeric characters may be entered as a series of two-digit key codes.
3. The first key depression simply identifies the key on which the desired character is stamped or printed. Press the key on which the character appears. For example, if character is **A**, **B** or **C**, press the **2** key.
4. The second key depression identifies a single character from the group (typically three letters) selected with the first keystroke. The character is identified by its position on the key. To select the first, press **1**. If the desired letter is the second of the three, press **2**. Press **3** if the desired letter is the third of the group.

5. Repeat Steps 3 and 4 for each alpha character in the Pair Gain System ID. When the last character has been entered, enter ** just as previously done in Step 2. This restores the numeric entry mode.

Special two-key sequences are assigned to the letters **Q** , **Z** and certain punctuation characters. Table 4-3 identifies these special key combinations.

Table 4-3. Two-Key Sequences-Non-Numeric Keypad

1st Key	2nd Key				
	1	2	3	4	5
1	(space)	.	,	-	/
	(period)	(comma)	(hyphen)	(slash)	
2	A	B	C		
3	D	E	F		
4	G	H	I		
5	J	K	L		
6	M	N	O		
7	P	R	S	Q	
8	T	U	V		
9	W	X	Y	Z	

6. Enter any trailing numbers that are part of the Pair Gain System ID.
7. Any combination of letters and numbers may be entered in this manner. Repeat the appropriate steps as necessary.
8. Enter a single star (*) to complete the Pair Gain System ID entry.

Menu Item Selection

DATU-RT functions are presented in a menu format through voice messages. Main Menu functions are announced as follows:

Note: Audio Monitor is functional on a Carrier System only if the line is busy.

- **DIAL 2 FOR AUDIO MONITOR.**
- **DIAL 33 FOR TIP-RING SHORT-TO-GROUND.**
- **DIAL 37 FOR RING GROUND.**
- **DIAL 38 FOR TIP GROUND.**
- **DIAL 44 FOR TIP-RING HIGH LEVEL TONE.**
- **DIAL 47 FOR RING HIGH LEVEL TONE.**

-
- **DIAL 48 FOR TIP HIGH LEVEL TONE.**
 - **DIAL 5 FOR LOW LEVEL TONE.**
 - **DIAL 6 TO OPEN SUBSCRIBER LINE.**
 - **DIAL 7 TO SHORT SUBSCRIBER LINE.**
 - **DIAL STAR (*) TO KEEP TEST AFTER DISCONNECT.**
 - **DIAL POUND (#) FOR NEW SUBSCRIBER LINE.**

If two or more options are associated with the selected function, a corresponding submenu is announced after the Main Menu item is selected. Table 4-1 presents a listing of both Main and submenu functions with their assigned keypad digits. Note the correlation between the names assigned to certain Main Menu functions and the standard alphabetical arrangement of the telephone keypad.

Line preparation functions are selectable as soon as the DATU-RT has determined the state of the subscriber line. If the line is idle, all functions are available. If the line is busy, the set of available functions is limited to audio monitor and low level tone (see Subscriber Line Status). Functions may be activated in any sequence, however, only one function may be active at a time. Selection of any menu item cancels the previously-active function. If an incorrect or invalid entry is made, the current function (if any) remains in effect.

An Access Timeout feature limits the time during which line preparation functions are sustained or allowed to remain active. The access timeout interval is preset at the factory to allow the selected function to remain active for up to 10 minutes. The factory setting also allows extension of this interval by simply selecting the same function again or, if desired, selecting a new function. The parameters associated with the Access Timeout feature are programmable and accessible only by the DATU-RT Administrator.

Announce Main Menu (Keypad Digit 1)

Selection of this function causes the DATU-RT to announce it's Main Menu. If selected while in a submenu, DATU-RT announces **ERROR** followed by the Main Menu.

1. Momentarily press **1** on the telephone keypad.
2. The DATU-RT announces it's Main Menu.

Audio Monitor (Keypad Digit 2)

The Audio Monitor function provides a means by which a busy line status reported by the DATU-RT may be verified. To protect the privacy of the subscriber, conversation is audible but unintelligible.

1. Momentarily press **2** on the telephone keypad.
2. The DATU-RT announces **AUDIO MONITOR**.
3. Monitor the line as required.

Although it may be selected, Audio Monitor is not functional on an idle carrier system line unless the bypass pair is used.

Audio Monitor is automatically disabled at regular intervals to insure that the DATU-RT is able to detect DTMF tones if an exceptionally strong audio signal is present. This occurs at regular six-second intervals and is of approximately two seconds duration.

Short-to-Ground (Keypad Digit 3)

This function is not available if the DATU-RT has determined that the line is busy. The DATU-RT announces the following error message if an attempt is made to invoke this function on a busy line **ERROR - BUSY LINE**.

The Short to Ground function is used to connect the Tip, Ring or both leads to Ground potential. If only a single lead (Tip or Ring) is selected, the opposite lead is unterminated.

1. Momentarily press **3** on the telephone keypad.
2. The DATU-RT issues the following submenu prompt:
 - a. **DIAL 3 FOR TIP-RING SHORT-TO-GROUND.**
 - b. **DIAL 7 FOR RING GROUND.**
 - c. **DIAL 8 FOR TIP GROUND.**
3. Momentarily press the key corresponding to the desired subfunction.
4. The DATU-RT identifies the selected subfunction with one of the following voice messages:

TIP-RING SHORT-To-GROUND - if submenu item **3** selected.

RING GROUND - if submenu item **7** selected.

TIP GROUND

- if submenu item **8** selected.

The selected function remains in effect until another function is selected, the access timeout interval is exceeded or the subscriber line is released.

The DATU-RT does not remain in the Short-to-Ground submenu after the subfunction is selected. To select another Short-to-Ground subfunction, both Main and submenu selections must be made.

High-Level Tone (Keypad Digit 4)

This function is not available if the DATU-RT has determined that the line is busy. The DATU-RT announces the following error message if an attempt is made to invoke this function on a busy line **ERROR - BUSY LINE**.

This function places a 577 Hz high-level (+22 dBm) interrupted tone bursts on the Tip lead, Ring lead or both. If a single lead is selected, the opposite lead is grounded. This function is typically used for the purpose of conductor or pair identification.

1. Momentarily press **4** on the telephone keypad.
2. The DATU-RT issues the following submenu prompt:
 - a. **DIAL 4 FOR TIP-RING HIGH-LEVEL TONE.**
 - b. **DIAL 7 FOR RING HIGH-LEVEL TONE.**
 - c. **DIAL 8 FOR TIP HIGH-LEVEL TONE.**
3. Momentarily press the key corresponding to the desired subfunction.
4. The DATU-RT identifies the selected subfunction with one of the following voice messages:

TIP-RING HIGH-LEVEL TONE - if submenu item **4** selected.

RING HIGH-LEVEL TONE - if submenu item **7** selected.

TIP HIGH-LEVEL - if submenu item **8** selected.

The selected function remains in effect until another function is selected, the access timeout interval is exceeded or the subscriber line is released.

The DATU-RT does not remain in the High-Level Tone submenu after the subfunction is selected. To select another High-Level Tone subfunction, both Main and submenu selections must be made.

Low-Level Tone (Keypad Digit 5)

This function places a 577 Hz low-level (-12 dBm) interrupted tone bursts on both the Tip and Ring leads. Because the tone signal is longitudinal, use of this function does not disrupt traffic on a busy line. Tone bursts can be heard only on a telephone instrument connected between Tip or Ring and Ground. This function is typically used for the purpose of conductor or pair identification on a busy subscriber line.

1. Momentarily press **5** on the telephone keypad.
2. The DATU-RT responds with the voice prompt **LOW-LEVEL TONE**.

The selected function remains in effect until another function is selected, the access timeout interval is exceeded or the subscriber line is released.

Open Subscriber Line (Keypad Digit 6)

This function is not available if the DATU-RT has determined that the line is busy. The DATU-RT announces **BUSY LINE**, if an attempt is made to invoke this function on a busy line.

The Open Subscriber Line function removes Battery and Ground potentials from the subscriber's Tip and Ring leads.

1. Momentarily press **6** on the telephone keypad.
2. The DATU-RT responds with the voice message **OPEN LINE**.

The selected function remains in effect until another function is selected, the access timeout interval is exceeded or the subscriber line is released.

Short Subscriber Line (Keypad Digit 7)

This function is not available if the DATU-RT has determined that the line is busy. The DATU-RT announces the following error message if an attempt is made to invoke this function on a busy line: **ERROR - BUSY LINE**.

The Short Subscriber Line function provides an electrical short across the subscriber's Tip and Ring leads.

1. Momentarily press **7** on the telephone keypad.
2. The DATU-RT responds with the voice message **SHORT LINE**.

The selected function remains in effect until another function is selected, the access timeout interval is exceeded or the subscriber line is released.

Permanent Signal Release (Keypad Digit 9)

This function is not available unless specifically enabled by the DATU-RT administrator. Unless enabled, any attempt to use this function results in the error message **ERROR - PERMANENT SIGNAL RELEASE DISABLED**.

Permanent Signal Release will function only on a line that the DATU-RT has identified as busy. An attempt to use this function on an idle line results in the error message **ERROR - IDLE LINE**.

The Permanent Signal Release function causes the removal of Battery and Ground potentials from a permanent signal line served by a step-by-step switch. This function is typically used to clear a busy condition resulting from a line fault so that normal line tests may be performed.

1. Momentarily press **9** on the telephone keypad.
2. The DATU-RT responds with the voice message **PERMANENT SIGNAL RELEASE**.
3. After executing the required sequence of operations, the DATU-RT tests the subscriber line to determine whether the busy condition has been cleared. The result of this test is then announced as follows:

OK	- if the line is idle.
BUSY LINE	- if the line is busy.

New Subscriber Line (Keypad Digit #)

This function releases the currently-held subscriber line so that another subscriber line may be accessed.

1. Momentarily press the **#** key on the telephone keypad.
2. The DATU-RT responds with DATU-RT dial tone.
3. Enter the new subscriber line number as done previously in the Subscriber Line Access section.

The voice message **TRUNK DISCONNECT ERROR** indicates the DATU-RT has detected an abnormal condition on the NTT. Line conditioning functions will not be available until the NTT problem is corrected.

Hold Test (Keypad Digit *[n])

The Hold Test feature provides a means by which a line condition asserted by the DATU-RT is maintained for a specified time interval after disconnecting from the DATU-RT. The duration of the hold test interval is entered through the telephone keypad and is specified in minutes. Any interval may be entered, however, the DATU-RT will not maintain a line condition longer than the access timeout interval. The programmed function is automatically cancelled by the DATU-RT when the specified time interval or, if of a shorter duration, the access timeout interval has elapsed.

1. Momentarily press the star (*) key on the telephone keypad.
2. The DATU-RT responds with the following voice prompt:

DIAL NUMBER OF MINUTES - if access timeout interval is 10 minutes or less.

DIAL 2 DIGITS FOR NUMBER OF MINUTES - if access timeout interval is more than 10 minutes.

3. Enter the desired hold time via the telephone keypad.

If the access timeout interval is set for 10 minutes or less, this must be a single-digit entry. Entry of a **0** is interpreted as an entry of 10 minutes.

If the access timeout interval is set for greater than 10 minutes, the hold time interval must be entered as a two-key sequence. This means that a leading **0** must be entered for a hold time interval of 9 minutes or less.

If no hold time entry is made, a default interval equal to one-half the access timeout interval is used.

4. The DATU-RT responds with the voice prompt **PLEASE HANG UP**.
5. The selected line conditioning function remains active for the specified hold time interval or, if of a shorter duration, the access timeout interval.

Single-Line Access—Carrier System Lines

This subsection describes the methods and procedures associated with single-line access of a subscriber loop served from a Carrier System RT. The procedures contained in this section should be used when it is necessary to access the DATU-RT on the same line that is to be conditioned.

DATU-RT Access

To access the DATU-RT:

1. Dial the telephone number assigned to the DATU-RT.
2. Wait for an uninterrupted 440 Hz DATU-RT dial tone indicating DATU-RT has answered and is ready for password entry.
3. Enter your password using the telephone keypad. Note that DATU-RT dial tone is removed upon entry of the first password digit.

The first digit of your password must be entered within 7 seconds after DATU-RT dial tone is heard. If more than 7 seconds elapses before entry of the first digit or between subsequent digits, the DATU-RT disconnects and releases the line.

4. DATU-RT dial tone is restored upon successful entry of a valid password.
5. DATU-RT disconnects and releases the line 7 seconds after the last key depression if an invalid or incomplete password is entered.
6. The voice message **ERROR, BAD NO-TEST TRUNK** indicates the DATU-RT has detected an abnormal condition on the NTT. Line conditioning functions will not be available until the NTT problem is corrected.

Subscriber Line Access

To access a subscriber's line:

Note: DATU-RT dial tone is removed upon entry of first digit.

1. Dial ** followed by the subscriber's telephone number.
2. If the first digit of the subscriber's telephone number is not entered within 7 seconds of DATU-RT dial tone, the voice prompt **DIAL SUBSCRIBER LINE NUMBER** is issued. If no digits have been entered after 60 seconds of DATU-RT dial tone, DATU-RT disconnects and releases the line.

Unless the DATU-RT is set to 10-digit dialing mode, entry of a telephone number not served by the CO, causes the DATU-RT to issue the following voice message **INVALID PREFIX. DIAL SUBSCRIBER LINE NUMBER**.

The absence of error messages indicates that the RT System has accepted the subscriber's telephone number.

Remote Terminal (RT) Access

To access a remote terminal:

1. Following entry of a valid subscriber line number, the DATU-RT issues the voice prompt **PLEASE ENTER PAIR GAIN SYSTEM ID. DIAL STAR TO END.**
2. Enter Pair Gain System ID using telephone keypad. To condition line from CO using the bypass pair, enter **0***.
3. Use the Alphanumeric Pair Gain System ID Entry section if the RT number includes alphabetic or punctuation characters. Otherwise, proceed to Step 1 in the Alphanumeric Pair Gain System ID Entry section.

If selected, the bypass pair must be in place between the host element of the DATU-RT at the CO and the RT.

Alphanumeric Pair Gain System ID Entry

This section describes the method by which alphabetical letters may be entered using a standard 12-key DTMF keypad.

1. Enter any leading numbers that are part of the Pair Gain System ID in the normal manner.
2. Enter ******. This special key sequence places the DATU-RT in a special mode in which alpha and certain other non-numeric characters may be entered as a series of two-digit key codes.
3. The first key depression simply identifies the key on which the desired character is stamped or printed. Press the key on which the character appears. For example, if character is **A**, **B** or **C**, press the **2** key.
4. The second key depression identifies a single character from the group (typically three letters) selected with the first keystroke. The character is identified by it's position on the key. To select the first, press **1**. If the desired letter is the second of the three, press **2**. Press **3** if the desired letter is the third of the group.
5. Repeat Steps 3 and 4 for each alpha character in the Pair Gain System ID. When the last character has been entered, enter ****** just as previously done in Step 2. This restores the numeric entry mode.

Special two-key sequences are assigned to the letters **Q**, **Z** and certain punctuation characters. Table 4-3 identifies these special key combinations.

-
6. Enter any trailing numbers that are part of the Pair Gain System ID.
 7. Any combination of letters and numbers may be entered in this manner. Repeat the appropriate steps as necessary.
 8. Enter a single star (*) to complete the Pair Gain System ID entry.
 9. After the Pair Gain System ID has been successfully entered, the DATU-RT issues the prompt **PLEASE ENTER PAIR NUMBER. DIAL STAR TO END.**
 10. Enter the pair number for the subscriber's line using the telephone keypad.
 11. The DATU-RT provides verification of the Pair Gain System ID entry with a voice message. If a valid ID was entered, the DATU-RT announces **ACCESS** followed by the ID previously entered. If the Pair Gain System ID is not valid or if the bypass pair was selected, the DATU-RT announces **USE BYPASS PAIR.**

Menu Item Selection

DATU-RT functions are presented in a menu format through voice messages. Main Menu functions are announced as follows:

- **DIAL 33 FOR TIP-RING SHORT-TO-GROUND.**
- **DIAL 37 FOR RING GROUND.**
- **DIAL 38 FOR TIP GROUND.**
- **DIAL 44 FOR TIP-RING HIGH LEVEL TONE.**
- **DIAL 47 FOR RING HIGH LEVEL TONE.**
- **DIAL 48 FOR TIP HIGH LEVEL TONE.**
- **DIAL 6 TO OPEN SUBSCRIBER LINE.**
- **DIAL 7 TO SHORT SUBSCRIBER LINE.**
- **DIAL POUND FOR NEW SUBSCRIBER LINE.**

If two or more options are associated with the selected function, a corresponding submenu is announced after the Main Menu item is selected. Table 4-2 presents a listing of both Main and submenu functions with their assigned keypad digits. Note the correlation between the names assigned to certain Main Menu functions and the standard alphabetical arrangement of the telephone keypad.

The following explains the selection and use of the functions available in the Single-Line Access mode.

Announce Main Menu (Keypad Digit 1)

Selection of this function causes the DATU-RT to announce its Main Menu. If selected while in a submenu, DATU-RT announces **ERROR** followed by the Main Menu.

1. Momentarily press **1** on the telephone keypad.
2. The DATU-RT announces its Main Menu.

Short-to-Ground (Keypad Digit 3)

The Short-to-Ground function is used to connect the Tip, Ring or both leads to Ground potential. If only a single lead (Tip or Ring) is selected, the opposite lead is unterminated.

1. Momentarily press **3** on the telephone keypad.
2. The DATU-RT issues the following submenu prompt:
 - a. **DIAL 3 FOR TIP-RING SHORT TO GROUND.**
 - b. **DIAL 7 FOR RING GROUND.**
 - c. **DIAL 8 FOR TIP GROUND.**
3. Momentarily press the key corresponding to the desired subfunction.
4. The DATU-RT identifies the selected subfunction with one of the following voice messages:

TIP-RING SHORT-TO-GROUND - if submenu item **3** selected.

RING GROUND - if submenu item **7** selected.

TIP GROUND - if submenu item **8** selected.

5. When prompted, enter the desired hold time interval and hang up (for detailed instructions, refer to Setting the Hold Time).

High-Level Tone (Keypad Digit 4)

This function places a 577 Hz high-level (+22 dBm) interrupted tone bursts on the Tip lead, Ring lead or both. If a single lead is selected, the opposite lead is grounded. This function is typically used for the purpose of conductor or pair identification.

1. Momentarily press **4** on the telephone keypad.
2. The DATU-RT issues the following submenu prompt:
 - a. **DIAL 4 FOR TIP-RING HIGH-LEVEL TONE.**
 - b. **DIAL 7 FOR RING HIGH-LEVEL TONE.**
 - c. **DIAL 8 FOR TIP HIGH-LEVEL TONE.**
3. Momentarily press the key corresponding to the desired subfunction.
4. The DATU-RT identifies the selected subfunction with one of the following voice messages:
 - TIP-RING HIGH-LEVEL TONE** - if submenu item **4** selected.
 - RING HIGH-LEVEL TONE** - if submenu item **7** selected.
 - TIP HIGH-LEVEL** - if submenu item **8** selected.
5. When prompted, enter the desired hold time interval and hang up (for detailed instructions, refer to Setting the Hold Time).

Open Subscriber Line (Keypad Digit 6)

The Open Subscriber Line function removes Battery and Ground potentials from the subscriber's Tip and Ring leads.

1. Momentarily press **6** on the telephone keypad.
2. The DATU-RT responds with the voice message **OPEN LINE.**
3. When prompted, enter the desired hold time interval and hang up (for detailed instructions, refer to Setting the Hold Time).

Short Subscriber Line (Keypad Digit 7)

The Short Subscriber Line function provides an electrical short across the subscriber's Tip and Ring leads.

1. Momentarily press **7** on the telephone keypad.
2. The DATU-RT responds with the voice message **SHORT LINE**.
3. When prompted, enter the desired hold time interval and hang up (for detailed instructions, refer to Setting the Hold Time).

Setting the Hold Time

The hold time setting defines how long the selected line condition is maintained after disconnecting from the DATU-RT. The duration of the hold time interval is entered through the telephone keypad and is specified in minutes. Any interval may be entered, however, the DATU-RT will not maintain a line condition longer than the access timeout interval. The selected line condition is automatically removed by the DATU-RT when the specified time interval or, if of a shorter duration, the access timeout interval has elapsed.

1. The DATU-RT prompts for the Hold Time setting as follows:

DIAL NUMBER OF MINUTES	- if access timeout interval is 10 minutes or less.
DIAL 2 DIGITS FOR NUMBER OF MINUTES	- if access timeout interval is more than 10 minutes.

2. Enter the desired hold time via the telephone keypad.

If the access timeout interval is set for 10 minutes or less, this must be a single-digit entry. Entry of a **0** is interpreted as an entry of 10 minutes.

If the access timeout interval is set for greater than 10 minutes, the Hold Time interval must be entered as a two-key sequence. This means that a leading **0** must be entered for a hold time interval of 9 minutes or less.

If no hold time entry is made, a default interval equal to one-half the access timeout interval is used.

-
3. The DATU-RT responds with the voice prompt **PLEASE HANG UP**.
 4. Disconnect from the DATU-RT by hanging up. Approximately 30 seconds after disconnect, the DATU-RT asserts the selected line conditioning function. The selected line function remains active for the specified hold time interval or, if of a shorter duration, the access timeout interval.

Troubleshooting Guide

5

Contents

Initial LED and Voltage Checks (Step 1)	5-2
Calling the DATU Checks (Step 2)	5-2
Calling the Subscriber Line Checks (Check 3)	5-3
Cut Through Checks (Step 4)	5-4
Disconnect Checks (Step 5)	5-4
Fault Location Flow Chart (Step 6)	5-5

This Troubleshooting Guide applies to the DATU-RT only. It also assumes that all programmable features (e.g., dialing method, prefix list, User and System passwords, etc.) are already properly programmed for the switch application.

Initial LED and Voltage Checks (Step 1)

1. Plug the DATU-RT into the MFT frame and observe the LEDs on the front panel of the DATU-RT.
2. After the initialization time of 10 seconds, the state of the LEDs should be as shown below, if not then go to Calling the DATU Checks (Step 2):

HI SLEEVE	Off
LO SLEEVE	Off
POWER	On
ALARM	Off
STATUS	Flashing

3. If all LEDs are off, check the power connections: Battery (-46 to -52 VDC) on pin 11 and CO ground on pin 18.
4. If the ALARM LED is on and the High Sleeve and Low Sleeve LEDs are cycling on and off (HI SLEEVE on and LO SLEEVE off for 10 seconds then HI SLEEVE off and LO SLEEVE on for $\frac{3}{4}$ second), check the NTT sleeve relay connection. The sleeve lead (pin 12) to the NTT should not be at a ground potential.
5. The DATU-RT, after three unsuccessful attempts to release the NTT, has activated its alarm circuitry - the ALARM LED is on and the alarm lead (pin 6) is at CO ground potential. When the DATU-RT is accessed, a **TRUNK DISCONNECT ERROR** message will be heard. DATU-RT will continue to test for the release of the NTT with the high and low sleeve current sequence. When the NTT is released, the DATU-RT alarm will automatically clear.
6. If the status LED is not flashing, replace the DATU-RT.

Calling the DATU Checks (Step 2)

1. Call the telephone number assigned to the DATU-RT.
2. If there is ringing, but the DATU-RT fails to trip the Ring and provide a 440 Hz tone:
 - a. Check the Tip and Ring (lip on pin 17 and Ring on pin 19) on the access line.

-
- b. The DATU-RT will not recognize an incoming call while it is making its three attempts to disconnect from the NTT. Wait 45 seconds and redial the access number.
 3. DATU-RT trips the Ring and provides a 440 Hz tone. Dial the User password.
 4. If a steady 440 Hz tone is heard, go to Calling the Subscriber Line Checks (Step 3).
 5. If after dialing in the User password, an interrupted 440 Hz tone is heard:
 - a. Check that the sleeve/ground pair is not reversed (sleeve [BS1] on pin 12 and ground [BS2] on 10).
 - b. Check for ground on ground lead (BS2) pin 10.



CAUTION:

Wait at least seven seconds before unplugging the DATU-RT if it has just been plugged in.

6. Check for a locked-up NTT. To release the NTT, unplug the DATU-RT, wait seven seconds, and plug the DATU-RT back in.

On ESS switches, if the NTT has been held up for a long time, it may be necessary to remove the busy status from the memory of the switch.
7. DATU-RT trips the Ring, provides a 440 Hz tone, and User password is dialed.
8. If a steady 440 Hz tone is heard, go to Calling the Subscriber Line Checks (Step 3).
9. If a busy tone is heard check the **H** relay adjustment of the NTT, if the switch is a 1 ESS, or the SL relay for step-by-step offices. Consult the appropriate NTT relay adjustment procedures.

Calling the Subscriber Line Checks (Check 3)

To check the subscriber line:

1. Dial the subscriber line.
2. If **OK** or **BUSY LINE** is heard, go to Cut Through Checks (Step 4).

-
3. If **ERROR - BAD NO TEST TRUNK** is heard:
 - a. Check the Tip and Ring wiring (Tip on pin 14 and Ring on pin 13) to the NTT.
 - b. Check that the correct dialing method for the NTT has been programmed into the DATU-RT.
 - c. Check that the Tip and Ring to the NTT are not shorted together or to any other leads.

Cut Through Checks (Step 4)

1. If the DATU-RT is returning the message **BUSY LINE on a line that is not busy, observe the High Sleeve LED** on the DATU-LC. If it is on, and the DATU-RT is in an office that does not provide a reversal, check that correct number of digits to access the NTT has been programmed into the DATU-RT. Too few digits may have been originally programmed.
2. If the Low Sleeve LED is on and the DATU-LC is returning the message **BUSY LINE** on a line that is known to be idle:
 - a. Check that the correct number of digits to access the NTT has been programmed into the DATU-RT. Too many digits may have been originally programmed.
 - b. Check that the subscriber's number is served by that switch.
3. If the LOW Sleeve is on and the DATU-LC has returned the message **OK** on a line that is busy:
 - a. The subscriber's number may be in a Hunt Group and is not testable by the DATU-RT.
 - b. The subscriber's number may have been entered wrong. Re-enter the number.

Disconnect Checks (Step 5)

Trouble with disconnecting:

1. Receive a CO busy tone when reaccessing the DATU-RT.
2. Check that the access line is a ground start line.

Fault Location Flow Chart (Step 6)

1. Translate the NTT access to DATU-RT exactly the same as the MLT access has been translated. Use a separate Trunk Group Number for the DATU-RT access.
2. Configure the DATU-RT access line for incoming ground start only.
3. Complete all frame wiring in accordance with Section 2, Installation.
4. Verify that the DATU-RT is a DATU-RT Model 24820-003.
5. Install the DATU-RT in the assigned MFT slot and observe the LEDs on the front panel of the DATU-RT.
6. Go to Flow Charts (see Figure 5-1 and Figure 5-2).

Note: For technical assistance, contact Harris Technical Support.

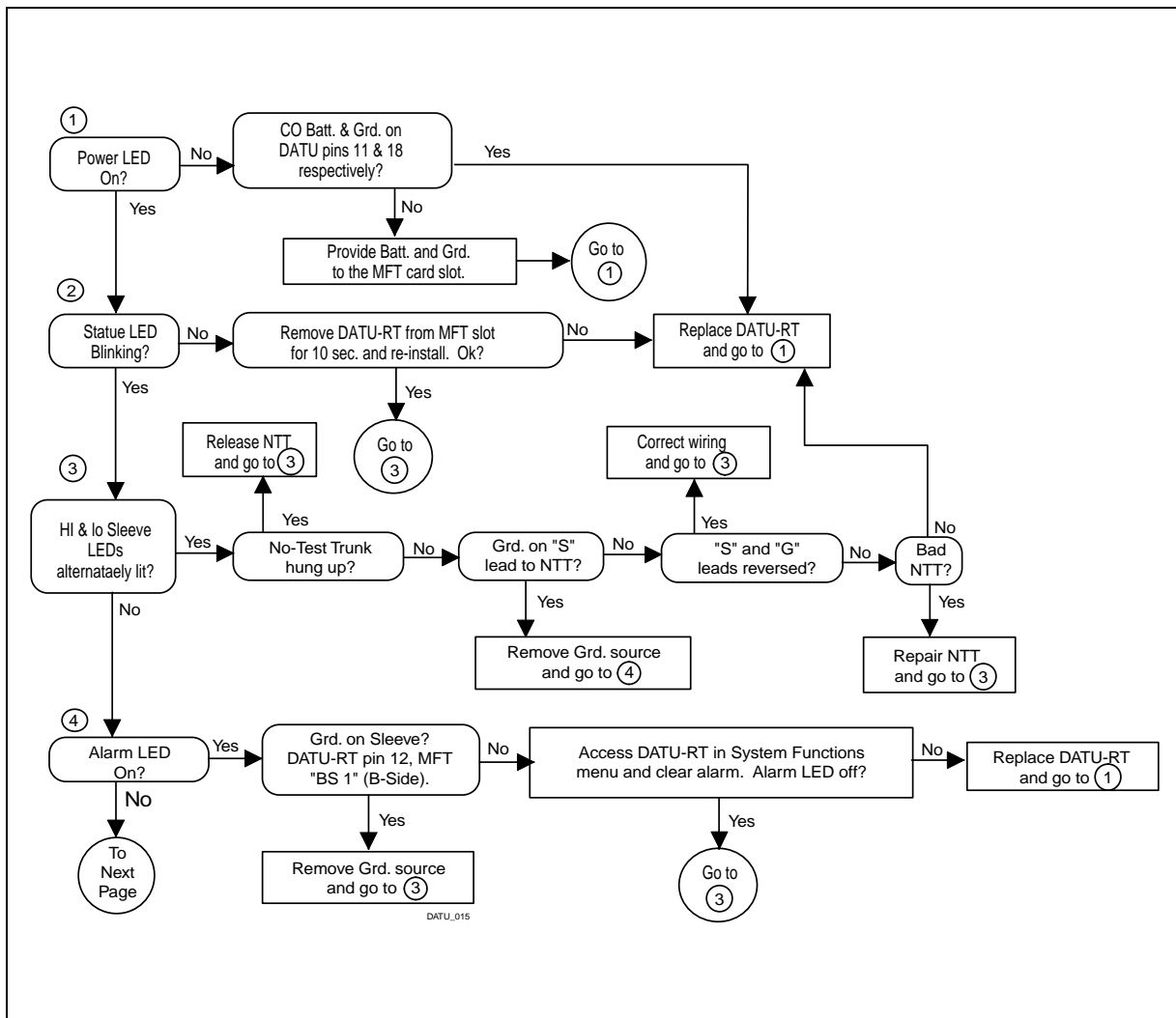

Figure 5-1. Fault Location Flow Chart (Sheet 1 of 6)

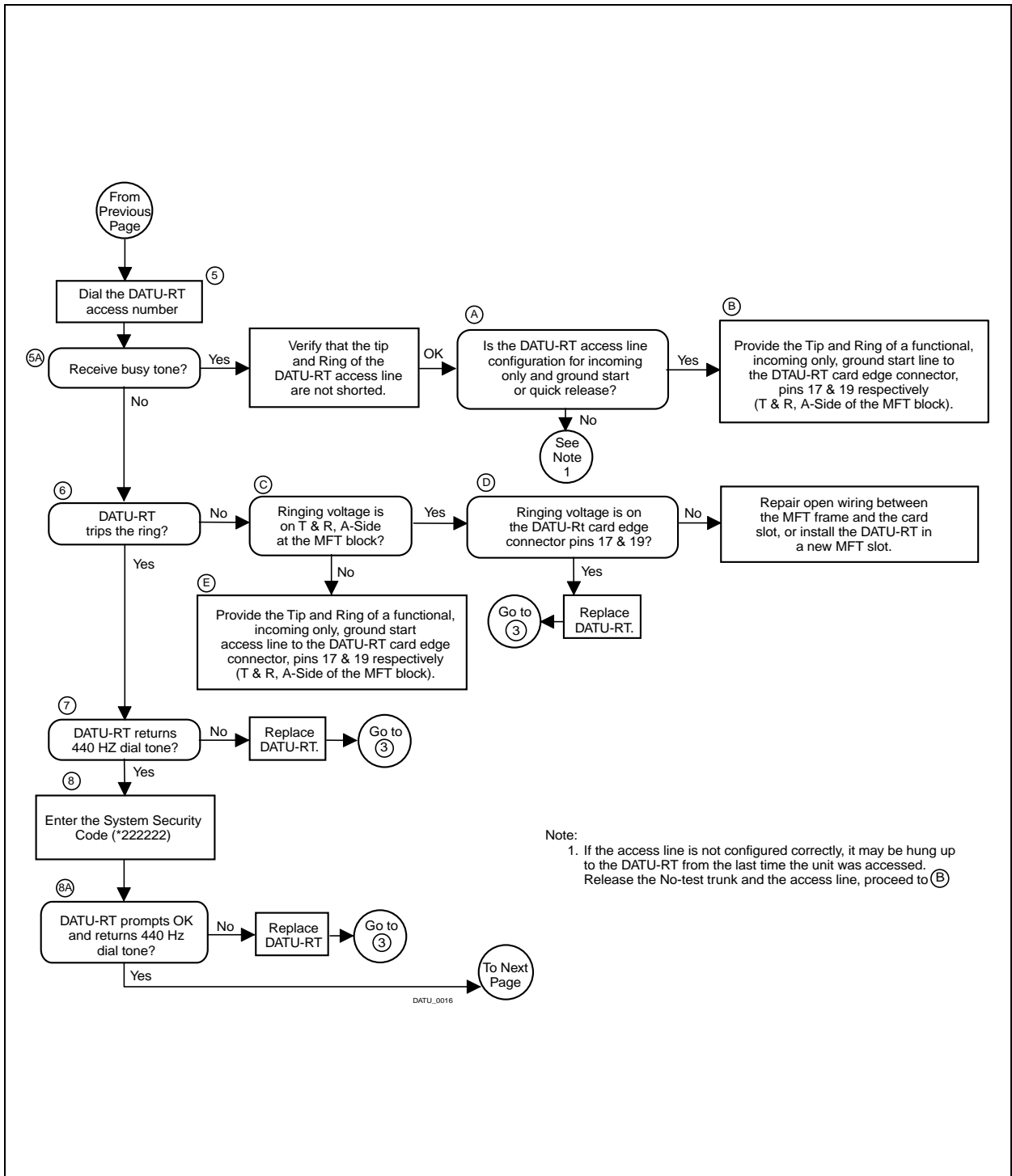

Figure 5-1. Fault Location Flow Chart (Sheet 2 of 6)

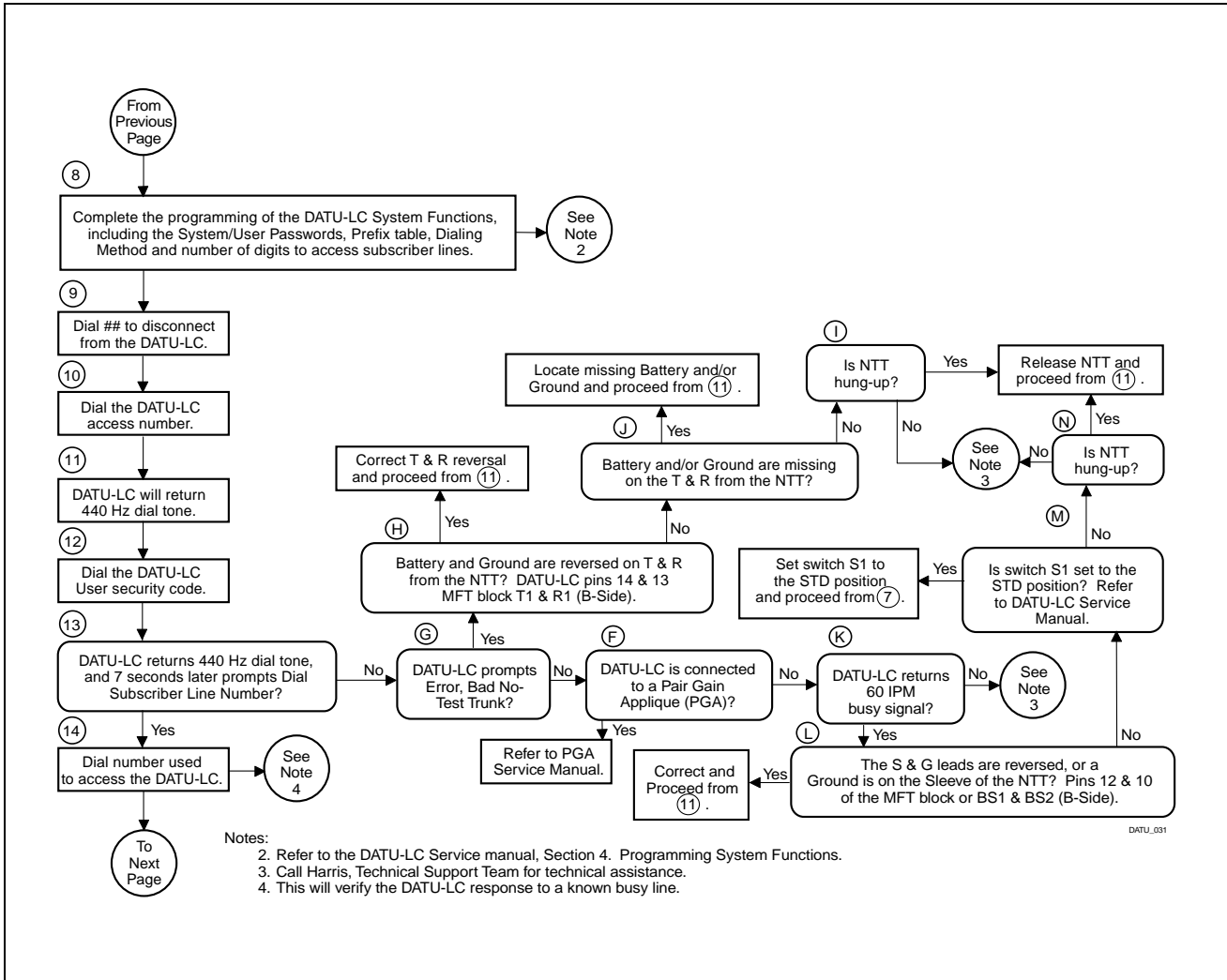

Figure 5-1. Fault Location Flow Chart (Sheet 3 of 6)

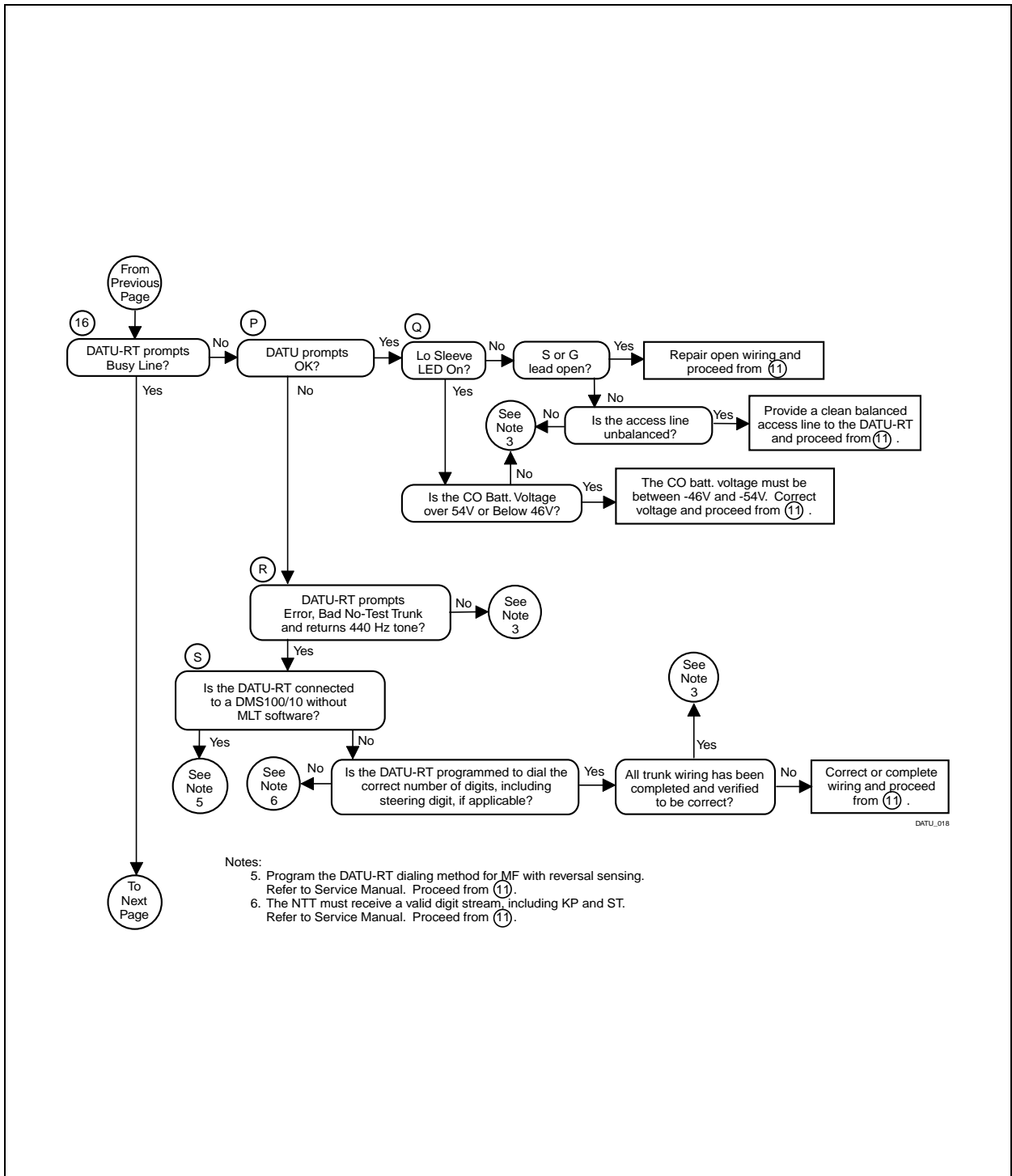

Figure 5-1. Fault Location Flow Chart (Sheet 4 of 6)

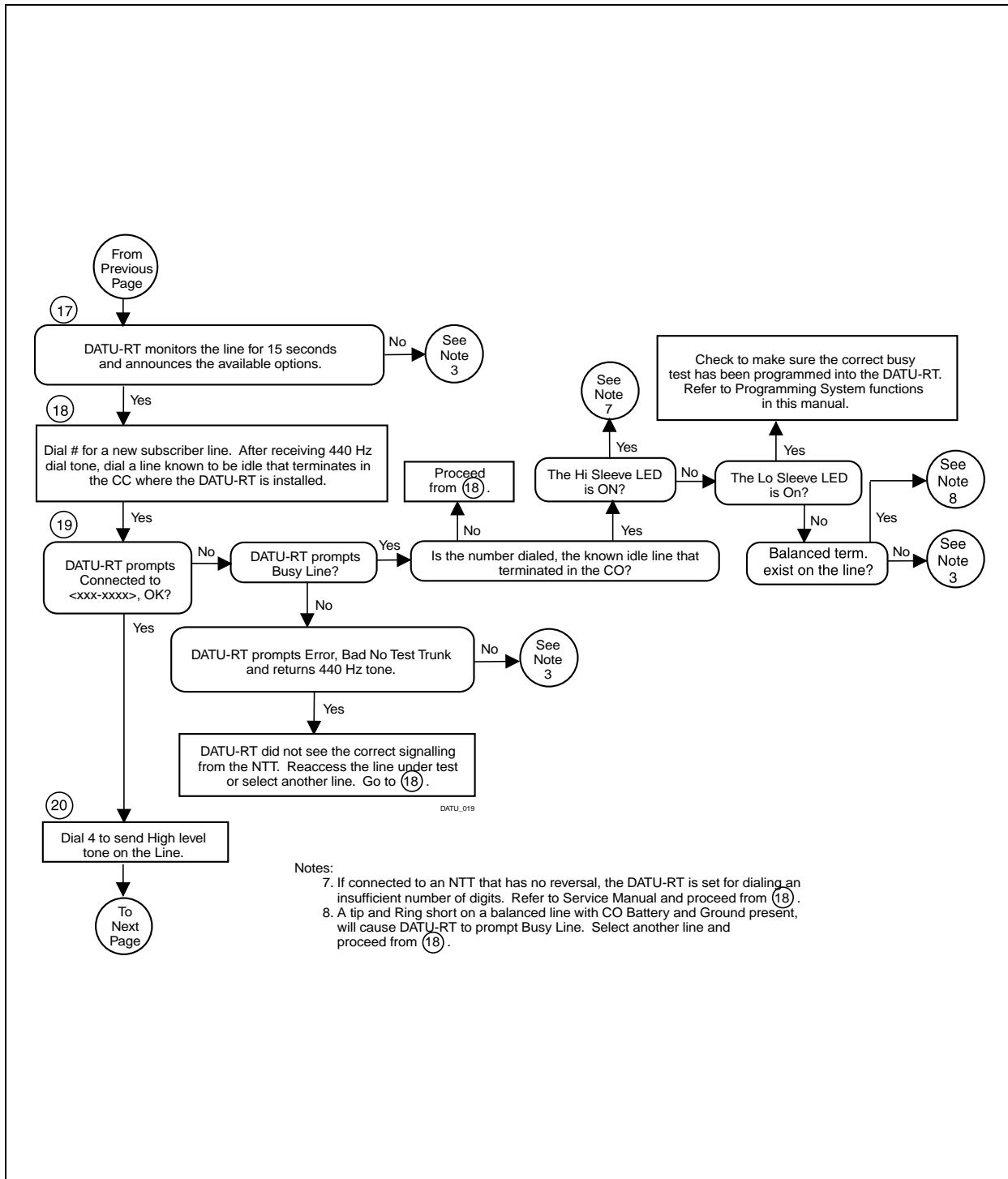

Figure 5-1. Fault Location Flow Chart (Sheet 5 of 6)

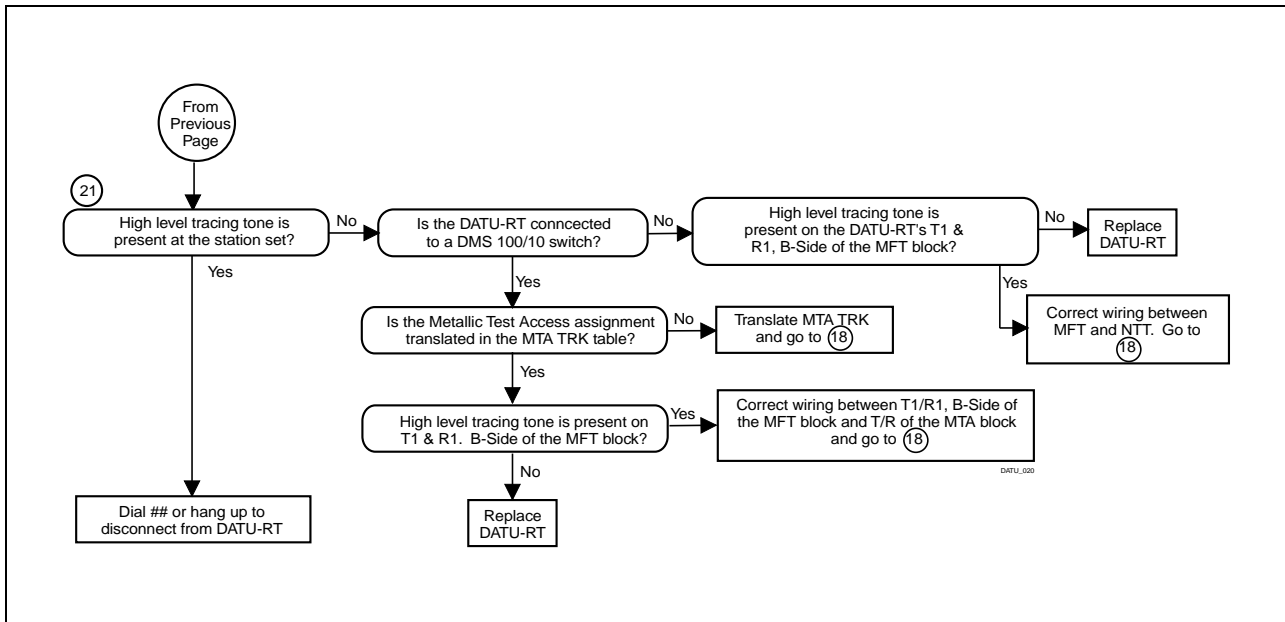

Figure 5-1. Fault Location Flow Chart (Sheet 6 of 6)

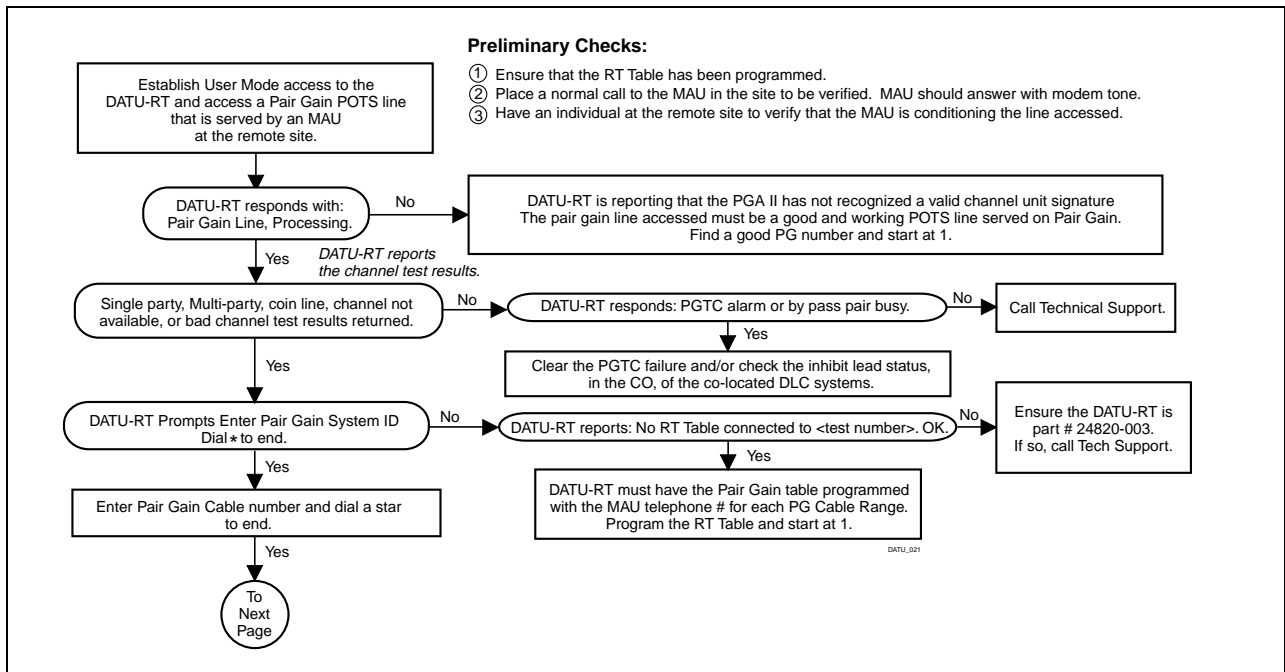

Figure 5-2. Verifying DATU-RT System Operations (Sheet 1 of 2)

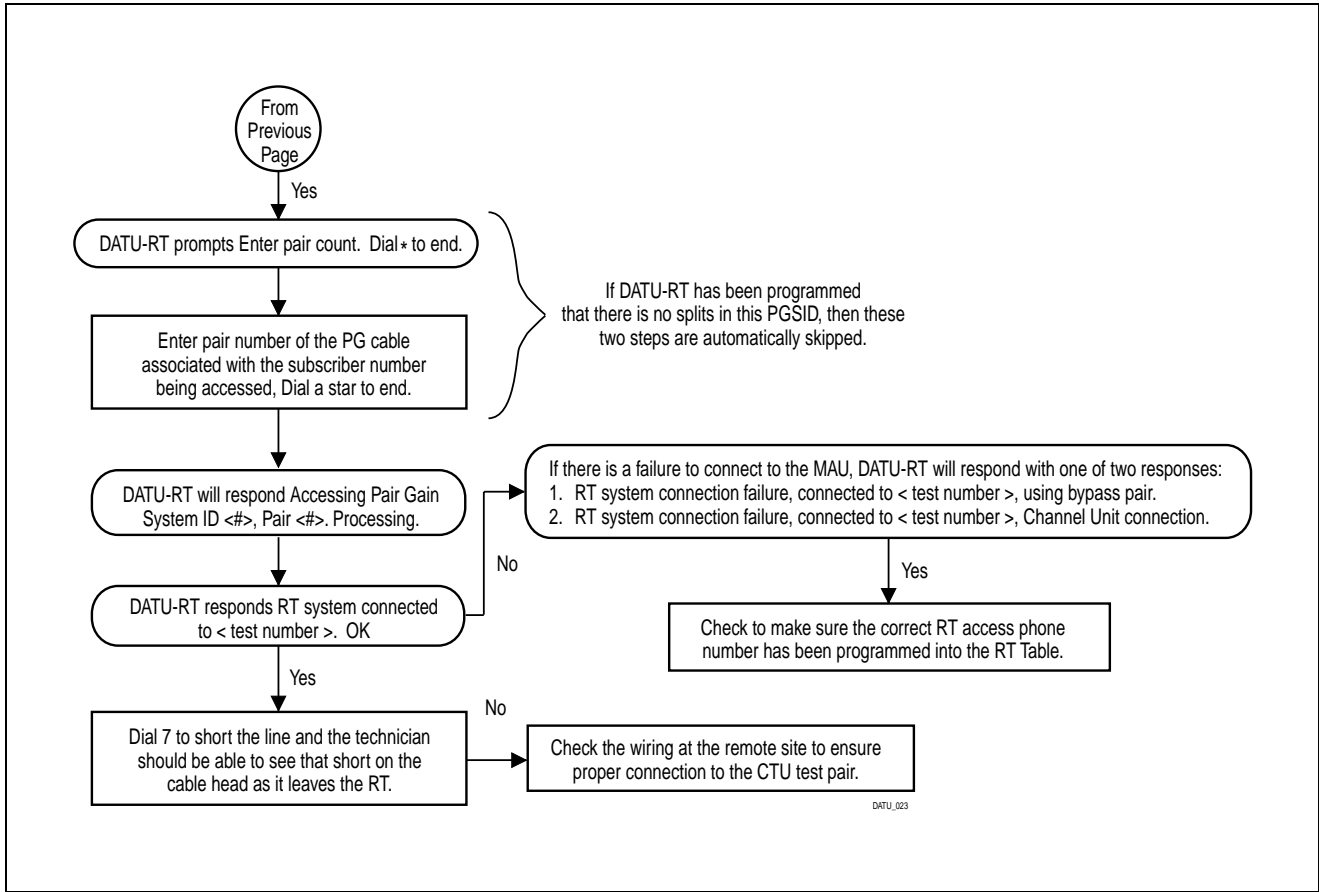

Figure 5-2. Verifying DATU-RT System Operations (Sheet 2 of 2)

Specifications

6

Contents

Physical Dimensions	6-2
Electrical	6-2
Access Line Interface (Ground Start)	6-2
No Test Trunk Interface	6-3
Test Function Parameters	6-4

Physical Dimensions

Length: 8.0 inches
Width: 7.5 inches
Height: 2.0 inches
Weight: 1.7 pounds

Electrical

Battery Input Requirement (measured with respect to CO ground):

- -46 to -54 Volts DC (VDC).
- 600 mA maximum.
- 2 volts peak-to-peak noise maximum from CO.

Access Line Interface (Ground Start)

Tip and Ring Parameters in Off-Hook Mode:

- Meets FCC Part 68 requirements.
- Resistance is 120 - 280 ohms at 20 to 80 mA.
- Minimum DC current required is 20 mA.
- Typical AC impedance, at 1 kHz is 640 ohms.

Tip and Ring Parameters in On-Hook Mode:

- Meets FCC Part 68 requirements.
- Minimum ring detect level is 65 volts AC rms.
- Uninterrupted pre-trip Ring duration is 300 ms.
- Ringer equivalence is 0.5B.

Secondary Dial Tone:

- Secondary dial tone is provided upon Ring trip, password entry, and new subscriber line selection.
- Dial tone is silenced when a digit is dialed or when the DATU-RT times out.
- Dial tone level is -16 dBm \pm 3 dBm.
- Dial tone frequency is 440 Hz \pm 8 Hz.
- Harmonic distortion is less than 10%.

DTMF Dial Decoding:

- Each incoming dual-tone signal is translated into one of the 12 character sets (see Table 6-1).
- Frequency deviations of up to $\pm 2.5\%$ are accepted and all deviations greater than $\pm 3.5\%$ are rejected.
- DTMF tones greater than 50 ms are accepted.
- Interdigit timing is greater than 40 ms and less than seven seconds are accepted.
- Signal strength per frequency of -20 to 0 dBm are accepted.

Voice Message Output:

- Average voice level is -13 dBm.
- Voice frequency range is 200 to 3,000 Hz.

Table 6-1. DTMF and MF Decoding

Character Set	Frequency Groups			
	DTMF		MF	
	Low	High	Low	High
1	697	1209	700	900
2 (ABC)	697	1336	700	1100
3 (DEF)	697	1477	900	1100
4 (GHI)	770	1209	700	1300
5 (JKL)	770	1336	900	1300
6 (MNO)	770	1477	1100	1300
7 (PRS)	852	1209	700	1500
8 (TUV)	852	1336	900	1500
9 (WXY)	852	1477	1100	1500
*	941	1209		
0	941	1336	1300	1500
#	941	1477		
KP			1100	1700
ST			1500	1700

No Test Trunk Interface

Tip and Ring Parameters in Idle Mode:

- Resistance is greater than 20M ohms.

Tip and Ring Parameters in Active Mode:

- Resistance is 100 to 180 ohms at 20 to 90 mA.
- Maximum DC current is 90 mA.
- Typical AC impedance, at 1 kHz is 660 ohms.

MF Output Parameters:

- Each outgoing dual-tone sinusoidal signal is translated from one of the 12 character sets (see Table 6-1).
- Frequency deviation is less than $\pm 2\%$.
- Signal strength per frequency is -5 to -15 dBm.
- Digit duration is 70 ms.
- Interdigital pause is 70 ms.

Dial Pulse Addressing Parameters:

- Break ratio is 60%.
- Repetition rate is 10 pulses per second.
- Interdigital time is 1,000 ms.

Sleeve Current Parameters:

- Low current mode is 7 to 10 mA into 120 ohm sleeve.
- High current mode is 50 to 70 mA into 120 ohm sleeve.
- Maximum external sleeve loop resistance is 700 ohms.

Test Function Parameters

- Open test resistance is greater than 20M ohms.
- Tip and Ring shorted is less than 2 ohms.
- Tone Test:
 - Frequency is 577 Hz.
 - Frequency error is less than $\pm 3\%$.

Low-Level Tone Test:

- Typical signal strength, measured Tip-to-Ground or Ring-to-Ground:
 - At the CO is -12 dBm \pm 3 dBm.
 - At 18,000 cable feet from the CO is -19 dBm.

High-Level Tone Test (Differential):

- Tip-to-Ring signal strength is +22 dBm \pm 3 dBm
- Tip-to-Ground or Ring-to-Ground signal strength is +17 dBm \pm 3 dBm.

