



**NONRESIDENT
TRAINING
COURSE**

SEPTEMBER 1998



Navy Electricity and Electronics Training Series

Module 17—Radio-Frequency Communications Principles

NAVEDTRA 14189

Although the words “he,” “him,” and “his” are used sparingly in this course to enhance communication, they are not intended to be gender driven or to affront or discriminate against anyone.

PREFACE

By enrolling in this self-study course, you have demonstrated a desire to improve yourself and the Navy. Remember, however, this self-study course is only one part of the total Navy training program. Practical experience, schools, selected reading, and your desire to succeed are also necessary to successfully round out a fully meaningful training program.

COURSE OVERVIEW: To introduce the student to the subject of Radio-Frequency Communications Principles who needs such a background in accomplishing daily work and/or in preparing for further study.

THE COURSE: This self-study course is organized into subject matter areas, each containing learning objectives to help you determine what you should learn along with text and illustrations to help you understand the information. The subject matter reflects day-to-day requirements and experiences of personnel in the rating or skill area. It also reflects guidance provided by Enlisted Community Managers (ECMs) and other senior personnel, technical references, instructions, etc., and either the occupational or naval standards, which are listed in the *Manual of Navy Enlisted Manpower Personnel Classifications and Occupational Standards*, NAVPERS 18068.

THE QUESTIONS: The questions that appear in this course are designed to help you understand the material in the text.

VALUE: In completing this course, you will improve your military and professional knowledge. Importantly, it can also help you study for the Navy-wide advancement in rate examination. If you are studying and discover a reference in the text to another publication for further information, look it up.

*1998 Edition Prepared by
EWC Gary L. Holloway*

Published by
NAVAL EDUCATION AND TRAINING
PROFESSIONAL DEVELOPMENT
AND TECHNOLOGY CENTER

**NAVSUP Logistics Tracking Number
0504-LP-026-8420**

Sailor's Creed

“I am a United States Sailor.

I will support and defend the Constitution of the United States of America and I will obey the orders of those appointed over me.

I represent the fighting spirit of the Navy and those who have gone before me to defend freedom and democracy around the world.

I proudly serve my country's Navy combat team with honor, courage and commitment.

I am committed to excellence and the fair treatment of all.”

TABLE OF CONTENTS

CHAPTER	PAGE
1. Introduction to Radio-Frequency Communications	1-1
2. Introduction to Communications Theory	2-1
3. Fundamental Systems Equipment	3-1
4. Introduction to Satellite Communications	4-1
5. Introduction to Miscellaneous Communications Systems and Equipment	5-1
 APPENDIX	
I. Glossary	AI-1
II. Reference List.....	AII-1
INDEX	INDEX-1

CREDITS

The figures listed below and included in this edition of NEETS, Module 17, *Radio-Frequency Communications Principles*, were provided by Martin Marietta DSCS III Program. Permission to use these illustrations is gratefully acknowledged.

<u>SOURCE</u>	<u>FIGURE</u>
Martin Marietta DSCS III Program (former company name: General Electric Company)	4-15
	4-16

NAVY ELECTRICITY AND ELECTRONICS TRAINING SERIES

The Navy Electricity and Electronics Training Series (NEETS) was developed for use by personnel in many electrical- and electronic-related Navy ratings. Written by, and with the advice of, senior technicians in these ratings, this series provides beginners with fundamental electrical and electronic concepts through self-study. The presentation of this series is not oriented to any specific rating structure, but is divided into modules containing related information organized into traditional paths of instruction.

The series is designed to give small amounts of information that can be easily digested before advancing further into the more complex material. For a student just becoming acquainted with electricity or electronics, it is highly recommended that the modules be studied in their suggested sequence. While there is a listing of NEETS by module title, the following brief descriptions give a quick overview of how the individual modules flow together.

Module 1, *Introduction to Matter, Energy, and Direct Current*, introduces the course with a short history of electricity and electronics and proceeds into the characteristics of matter, energy, and direct current (dc). It also describes some of the general safety precautions and first-aid procedures that should be common knowledge for a person working in the field of electricity. Related safety hints are located throughout the rest of the series, as well.

Module 2, *Introduction to Alternating Current and Transformers*, is an introduction to alternating current (ac) and transformers, including basic ac theory and fundamentals of electromagnetism, inductance, capacitance, impedance, and transformers.

Module 3, *Introduction to Circuit Protection, Control, and Measurement*, encompasses circuit breakers, fuses, and current limiters used in circuit protection, as well as the theory and use of meters as electrical measuring devices.

Module 4, *Introduction to Electrical Conductors, Wiring Techniques, and Schematic Reading*, presents conductor usage, insulation used as wire covering, splicing, termination of wiring, soldering, and reading electrical wiring diagrams.

Module 5, *Introduction to Generators and Motors*, is an introduction to generators and motors, and covers the uses of ac and dc generators and motors in the conversion of electrical and mechanical energies.

Module 6, *Introduction to Electronic Emission, Tubes, and Power Supplies*, ties the first five modules together in an introduction to vacuum tubes and vacuum-tube power supplies.

Module 7, *Introduction to Solid-State Devices and Power Supplies*, is similar to module 6, but it is in reference to solid-state devices.

Module 8, *Introduction to Amplifiers*, covers amplifiers.

Module 9, *Introduction to Wave-Generation and Wave-Shaping Circuits*, discusses wave generation and wave-shaping circuits.

Module 10, *Introduction to Wave Propagation, Transmission Lines, and Antennas*, presents the characteristics of wave propagation, transmission lines, and antennas.

Module 11, *Microwave Principles*, explains microwave oscillators, amplifiers, and waveguides.

Module 12, *Modulation Principles*, discusses the principles of modulation.

Module 13, *Introduction to Number Systems and Logic Circuits*, presents the fundamental concepts of number systems, Boolean algebra, and logic circuits, all of which pertain to digital computers.

Module 14, *Introduction to Microelectronics*, covers microelectronics technology and miniature and microminiature circuit repair.

Module 15, *Principles of Synchros, Servos, and Gyros*, provides the basic principles, operations, functions, and applications of synchro, servo, and gyro mechanisms.

Module 16, *Introduction to Test Equipment*, is an introduction to some of the more commonly used test equipments and their applications.

Module 17, *Radio-Frequency Communications Principles*, presents the fundamentals of a radio-frequency communications system.

Module 18, *Radar Principles*, covers the fundamentals of a radar system.

Module 19, *The Technician's Handbook*, is a handy reference of commonly used general information, such as electrical and electronic formulas, color coding, and naval supply system data.

Module 20, *Master Glossary*, is the glossary of terms for the series.

Module 21, *Test Methods and Practices*, describes basic test methods and practices.

Module 22, *Introduction to Digital Computers*, is an introduction to digital computers.

Module 23, *Magnetic Recording*, is an introduction to the use and maintenance of magnetic recorders and the concepts of recording on magnetic tape and disks.

Module 24, *Introduction to Fiber Optics*, is an introduction to fiber optics.

Embedded questions are inserted throughout each module, except for modules 19 and 20, which are reference books. If you have any difficulty in answering any of the questions, restudy the applicable section.

Although an attempt has been made to use simple language, various technical words and phrases have necessarily been included. Specific terms are defined in Module 20, *Master Glossary*.

Considerable emphasis has been placed on illustrations to provide a maximum amount of information. In some instances, a knowledge of basic algebra may be required.

Assignments are provided for each module, with the exceptions of Module 19, *The Technician's Handbook*; and Module 20, *Master Glossary*. Course descriptions and ordering information are in NAVEDTRA 12061, *Catalog of Nonresident Training Courses*.

Throughout the text of this course and while using technical manuals associated with the equipment you will be working on, you will find the below notations at the end of some paragraphs. The notations are used to emphasize that safety hazards exist and care must be taken or observed.

WARNING

AN OPERATING PROCEDURE, PRACTICE, OR CONDITION, ETC., WHICH MAY RESULT IN INJURY OR DEATH IF NOT CAREFULLY OBSERVED OR FOLLOWED.

CAUTION

AN OPERATING PROCEDURE, PRACTICE, OR CONDITION, ETC., WHICH MAY RESULT IN DAMAGE TO EQUIPMENT IF NOT CAREFULLY OBSERVED OR FOLLOWED.

NOTE

An operating procedure, practice, or condition, etc., which is essential to emphasize.

INSTRUCTIONS FOR TAKING THE COURSE

ASSIGNMENTS

The text pages that you are to study are listed at the beginning of each assignment. Study these pages carefully before attempting to answer the questions. Pay close attention to tables and illustrations and read the learning objectives. The learning objectives state what you should be able to do after studying the material. Answering the questions correctly helps you accomplish the objectives.

SELECTING YOUR ANSWERS

Read each question carefully, then select the BEST answer. You may refer freely to the text. The answers must be the result of your own work and decisions. You are prohibited from referring to or copying the answers of others and from giving answers to anyone else taking the course.

SUBMITTING YOUR ASSIGNMENTS

To have your assignments graded, you must be enrolled in the course with the Nonresident Training Course Administration Branch at the Naval Education and Training Professional Development and Technology Center (NETPDTC). Following enrollment, there are two ways of having your assignments graded: (1) use the Internet to submit your assignments as you complete them, or (2) send all the assignments at one time by mail to NETPDTC.

Grading on the Internet: Advantages to Internet grading are:

- you may submit your answers as soon as you complete an assignment, and
- you get your results faster; usually by the next working day (approximately 24 hours).

In addition to receiving grade results for each assignment, you will receive course completion confirmation once you have completed all the

assignments. To submit your assignment answers via the Internet, go to:

<http://courses.cnet.navy.mil>

Grading by Mail: When you submit answer sheets by mail, send all of your assignments at one time. Do NOT submit individual answer sheets for grading. Mail all of your assignments in an envelope, which you either provide yourself or obtain from your nearest Educational Services Officer (ESO). Submit answer sheets to:

COMMANDING OFFICER
NETPDTC N331
6490 SAUFLEY FIELD ROAD
PENSACOLA FL 32559-5000

Answer Sheets: All courses include one “scannable” answer sheet for each assignment. These answer sheets are preprinted with your SSN, name, assignment number, and course number. Explanations for completing the answer sheets are on the answer sheet.

Do not use answer sheet reproductions: Use only the original answer sheets that we provide—reproductions will not work with our scanning equipment and cannot be processed.

Follow the instructions for marking your answers on the answer sheet. Be sure that blocks 1, 2, and 3 are filled in correctly. This information is necessary for your course to be properly processed and for you to receive credit for your work.

COMPLETION TIME

Courses must be completed within 12 months from the date of enrollment. This includes time required to resubmit failed assignments.

PASS/FAIL ASSIGNMENT PROCEDURES

If your overall course score is 3.2 or higher, you will pass the course and will not be required to resubmit assignments. Once your assignments have been graded you will receive course completion confirmation.

If you receive less than a 3.2 on any assignment and your overall course score is below 3.2, you will be given the opportunity to resubmit failed assignments. **You may resubmit failed assignments only once.** Internet students will receive notification when they have failed an assignment--they may then resubmit failed assignments on the web site. Internet students may view and print results for failed assignments from the web site. Students who submit by mail will receive a failing result letter and a new answer sheet for resubmission of each failed assignment.

COMPLETION CONFIRMATION

After successfully completing this course, you will receive a letter of completion.

ERRATA

Errata are used to correct minor errors or delete obsolete information in a course. Errata may also be used to provide instructions to the student. If a course has an errata, it will be included as the first page(s) after the front cover. Errata for all courses can be accessed and viewed/downloaded at:

<http://www.advancement.cnet.navy.mil>

STUDENT FEEDBACK QUESTIONS

We value your suggestions, questions, and criticisms on our courses. If you would like to communicate with us regarding this course, we encourage you, if possible, to use e-mail. If you write or fax, please use a copy of the Student Comment form that follows this page.

For subject matter questions:

E-mail: n315.products@cnet.navy.mil
Phone: Comm: (850) 452-1001, ext. 1728
DSN: 922-1001, ext. 1728
FAX: (850) 452-1370
(Do not fax answer sheets.)
Address: COMMANDING OFFICER
NETPDTC N315
6490 SAUFLEY FIELD ROAD
PENSACOLA FL 32509-5237

For enrollment, shipping, grading, or completion letter questions

E-mail: fleetservices@cnet.navy.mil
Phone: Toll Free: 877-264-8583
Comm: (850) 452-1511/1181/1859
DSN: 922-1511/1181/1859
FAX: (850) 452-1370
(Do not fax answer sheets.)
Address: COMMANDING OFFICER
NETPDTC N331
6490 SAUFLEY FIELD ROAD
PENSACOLA FL 32559-5000

NAVAL RESERVE RETIREMENT CREDIT

If you are a member of the Naval Reserve, you will receive retirement points if you are authorized to receive them under current directives governing retirement of Naval Reserve personnel. For Naval Reserve retirement, this course is evaluated at 7 points. (Refer to *Administrative Procedures for Naval Reservists on Inactive Duty*, BUPERSINST 1001.39, for more information about retirement points.)

THIS PAGE LEFT BLANK INTENTIONALLY.

Student Comments

Course Title: NEETS Module 17
Radio-Frequency Communications Principles

NAVEDTRA: 14189 **Date:** _____

We need some information about you:

Rate/Rank and Name: _____ SSN: _____ Command/Unit _____

Street Address: _____ City: _____ State/FPO: _____ Zip _____

Your comments, suggestions, etc.:

<p>Privacy Act Statement: Under authority of Title 5, USC 301, information regarding your military status is requested in processing your comments and in preparing a reply. This information will not be divulged without written authorization to anyone other than those within DOD for official use in determining performance.</p>
--

NETPDTC 1550/41 (Rev 4-00)

CHAPTER 1

INTRODUCTION TO RADIO-FREQUENCY COMMUNICATIONS

LEARNING OBJECTIVES

Learning objectives are stated at the beginning of each chapter. These learning objectives serve as a preview of the information you are expected to learn in the chapter. The comprehensive check questions are based on the objectives. By successfully completing the OCC/ECC, you indicate that you have met the objectives and have learned the information. The learning objectives are listed below.

Upon completion of this chapter, you will be able to:

1. Define electrical telecommunications.
2. Describe the use of radiotelegraph, radiotelephone, teletypewriter, and facsimile.
3. Define and describe the interrelationships of the system, set, group, unit, assembly, subassembly, part, and reference designations.
4. State the frequency ranges of the various frequency bands and describe the most common uses of those bands by the Navy.
5. Describe a strategic communications link.
6. Describe a tactical communications link.
7. Describe the five basic communications modes of operation.
8. Describe a switched communications network.
9. Describe the purpose of the two Navy-only networks.

INTRODUCTION TO NAVAL TELECOMMUNICATIONS

When the wireless (radiotelegraph) was invented, the Navy saw a possible use for it. It could be used for communications from shore stations to ships along the coast. In 1899, the first official naval radio message was sent from ship to shore. It only traveled a distance of 20 miles but that was a start. The next advance was in 1916 when the Navy first used radiotelephone between ships. Three years later the first airborne radio was used to communicate with a ground station. In the early years, communications was not the best because of poor tuning techniques. Receivers often did not pick up the signal. This problem was almost eliminated in 1931 when the first superheterodyne receivers were installed in the fleet. In 1944, another important event took place. The first successful radio teletypewriter transmissions between ships were completed. The first successful use of radiophoto (facsimile) occurred in 1945 with the transmission of the surrender document signing that ended World War II. Naval communications has grown tremendously in size and complexity since then.

The fleets of our modern Navy travel faster and are spread over greater areas of ocean than any seagoing force of the past. Commanders and their subordinates throughout the Department of the Navy use the facilities of naval communications as a primary method of communicating.

Naval communications relies on top performance from all of its assigned personnel. Reliable, secure, and timely transmission and receipt of information, based on wartime requirements, is the ultimate goal.

Previous modules have discussed electronic components or circuitry in individual units. In this chapter we will tie up some loose ends for you and discuss radio-frequency communications.

We will cover the considerations involved in receiving or transmitting a radio-frequency signal between two or more geographic locations. Let's start by defining telecommunications.

TELECOMMUNICATIONS refers to communications over a distance and includes any transmission, emission, or reception of signs, signals, writings, images, or sounds. Intelligence produced by visual means, oral means, wire, radio, or other electromagnetic systems are also included. Electrical, visual, and sound telecommunications are all used in the Navy. In this chapter we will talk only about electrical types of telecommunications.

ELECTRICAL

The types of electrical communications are radio and wire. Radio uses electromagnetic waves to transmit and receive intelligence. The waves are not guided by a physical path between sender and receiver. Wire uses conductors to carry these waves. Radio is the most important method the Navy has of communicating between widely separated forces. The transmission methods we will be discussing are radiotelegraph, radiotelephone, teletypewriter, and facsimile.

Radiotelegraph

Radiotelegraph transmissions are referred to as continuous wave (cw) telegraphy. Cw is a manual or automatic system of transmitting signals using a wave of radio-frequency (rf) energy. The radio operator separates a continuously transmitted wave into dots and dashes based on the Morse code. This is accomplished by opening and closing a telegraphic hand key.

Radiotelegraphy was the first means of radio communications that had military and commercial importance. Radiotelegraph still is used as a means of communication to, from, and among widely separated units of the Navy.

Relative slow speed of transmission and the requirement for experienced operators are the major disadvantages of radiotelegraph. The main advantage is reliability. A thinking person at both sending and receiving stations provides a capability of being understood not present in automated systems.

Radiotelephone

Radiotelephone is one of the most useful military communications methods. Because of its directness, convenience, and ease of operation, radiotelephone is used by ships, aircraft, and shore stations. It has many applications and is used for ship-to-shore, shore-to-ship, ship-to-ship, air-to-ship, ship-to-air, air-to-ground, and ground-to-air communications. Modern means of operation make it possible to communicate around the world by radiotelephone. One of the most important uses of radiotelephone is short-range tactical communications. This method permits tactical commanders to communicate directly with other ships. Little delay results while a message is prepared for transmission, and acknowledgments can be returned instantly. Radiotelephone equipment for tactical use usually is operated on frequencies that are high enough to have line-of-sight characteristics; that is, the waves do not

follow the curvature of the earth. As you know, these characteristics limit the usual range of radiotelephone from 20 to 25 miles. This is important because it reduces the chances of the enemy intercepting the message. Radiotelephone procedures can be learned easily by persons with no other training in communications.

Radiotelephone has some disadvantages. You may find transmissions unreadable because of static, enemy interference, or high local noise level caused by shouts, gunfire, and bomb or shell bursts. Wave propagation characteristics of radiotelephone frequencies sometimes are unpredictable, and tactical transmissions may be heard from great distances. Most radiotelephone messages are in plain language, and if information is to be kept from the enemy, users must keep their messages short, stick to the proper procedures, and be careful of what they say.

Q1. What are the two types of electrical communications?

Q2. What is the main advantage of radiotelegraph communications?

Q3. Why is radiotelephone one of the most useful methods of military communications?

Q4. What are the disadvantages of radiotelephone communications?

Teletypewriter

Teletypewriter (tty) signals may be transmitted by either landline (wire), cable, or radio. The landline tty is used both by the military services and by commercial communication companies. The Navy uses radio teletypewriter (rtty) mainly for high-speed automatic communications across ocean areas. The tty unit is equipped with a keyboard similar to a typewriter. When the operator presses a key, a sequence of signals is transmitted. At receiving stations, the signals are fed into terminal equipment that translates the sequences of signals into letters, figures, and symbols and types the messages automatically.

The rtty mode of transmission and reception is rapidly becoming more efficient and reliable for communications between ships and from ship-to-shore. Ships copy what is known as "fleet broadcast" messages on rtty. The speed at which message traffic is transmitted on rtty circuits depends on the equipment in use. Normal speed of operation is 100 words per minute, but it may be faster or slower. You may find high-speed equipment, capable of printing a line or even a page at a time, in some communications centers. The use of rtty has brought about a considerable savings in manpower.

Facsimile

Facsimile (fax) is the process used to transmit photographs, charts, and other graphic information electronically. The image to be transmitted is scanned by a photoelectric cell. Electrical changes in the cell output, corresponding to the light and dark areas being scanned, are transmitted to the receiver. At the receiver, the signal operates a recorder that reproduces the picture. The fax signals may be transmitted either by landline or radio.

Facsimile transmissions suffer distortion from all of the common sources of interference experienced with ordinary radiotelegraph and radio teletypewriter. Certain characteristics of TIF transmission make it less susceptible to complete loss of intelligence. For example, picture quality will be downgraded by any noise bursts, since facsimile recording is a continuous recording of signals coming from a receiver. However, because the machine scans material at the rate of about 100 lines per inch, each line is only 1/100th of an inch high. So you can see, if a noise burst interferes with the signal, it will distort a line only 1/100th of an inch high, leaving the image still readable. Under similar circumstances on a conventional rtty circuit, such distortion could cause a portion of the page copy to be unreadable.

Facsimile transmission is not intended to be a replacement for teletypewriter and other general methods of transmission. It is an important communications supplement and provides a means of handling certain types of graphic and pictorial intelligence by swift communications methods. It is widely used by the Navy weather information services and ship and station weather centers to obtain the latest weather maps. Chances are the photo you saw in the newspaper was transmitted by facsimile.

Q5. What is the main use of a radio teletypewriter?

Q6. What is facsimile?

SYSTEM INTRODUCTION

Until recently, RADIO COMMUNICATIONS brought to mind either telegraphy (cw), voice (AM), or possibly radio teletypewriter (rtty) communications. Today, radio communications has become a highly sophisticated field of electronics. Even small Navy ships have the capability to "come up" on the commonly used ship-to-ship, ship-to-air, and ship-to-shore communications circuits. These circuit operations are accomplished through the use of compatible and flexible communications systems.

A communications system (as you will see later in this chapter) consists of two or more equipment sets (sets will be explained a little later). Communications systems follow the system subdivision shown in figure 1-1. Systems are arranged and interconnected to perform a circuit operation that cannot be performed by any single piece of equipment. Navy communications systems vary from the simple to the very complex, depending upon the circuit operations involved. Because a Navy ship must use every inch of available space, the communications equipment may be spread over several portions of the ship, for instance, receivers in one location, transmitters in another, and terminal equipment in another. The equipment must be installed in such a manner that it is flexible and can be used interchangeably with other installed communications equipment. Consequently, large numbers of sets which make up the shipboard communications system are installed and are capable of operating separately and simultaneously. Flexibility is provided through a complex arrangement of interconnections. These allow the physically separated equipment to be selectively switched (patched) by you into different circuit configurations.

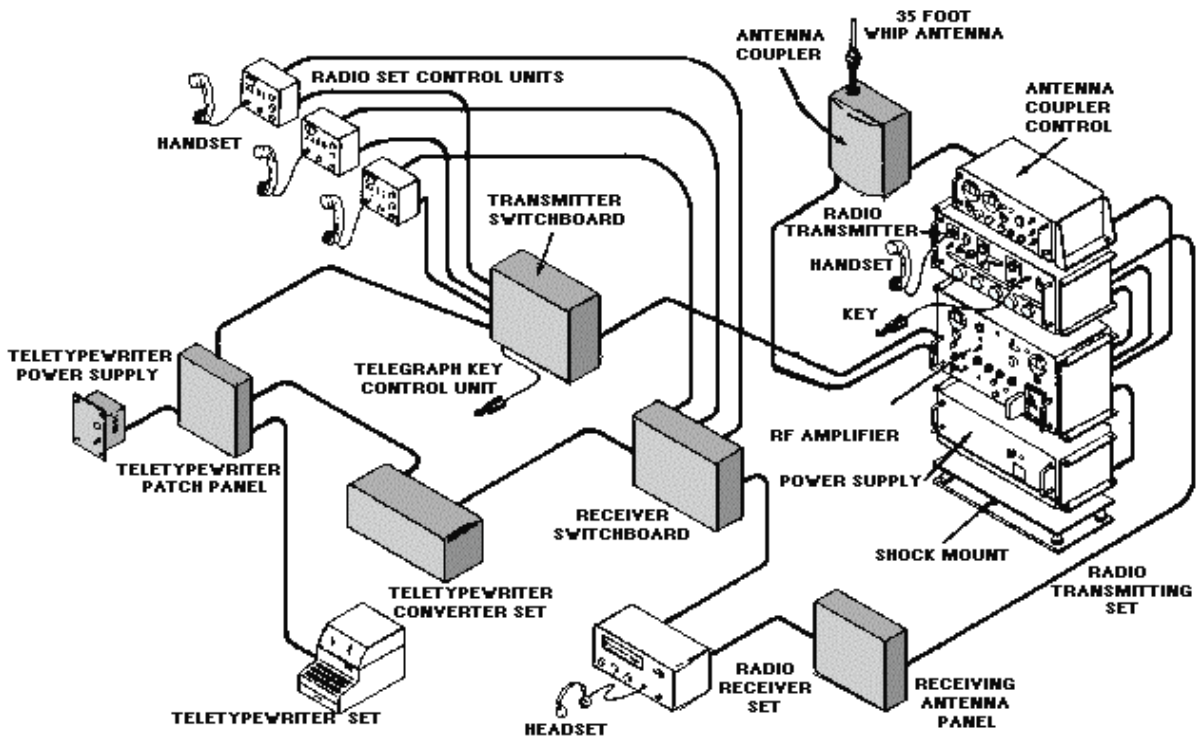

Figure 1-2.—Communications system pictorial view.

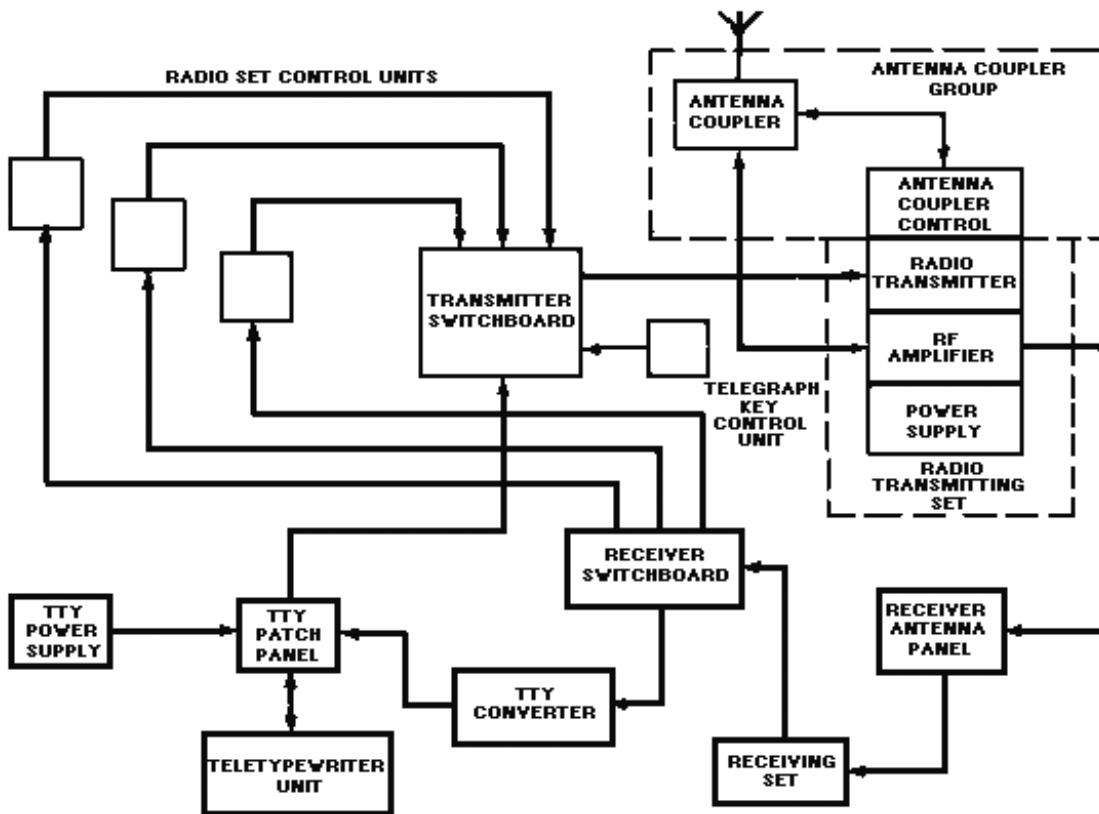

Figure 1-3.—Communications system block diagram.

Set

A SET consists of a unit or units and the assemblies, subassemblies, and parts connected or associated together to perform a specific function. A good example of this is a radio receiving set or a radio transmitting set.

Figure 1-4 is a block diagram of a radio transmitting set. It consists of a radio-frequency amplifier unit (1), a radio transmitter unit (2), a power supply unit (3), and an antenna coupler group.

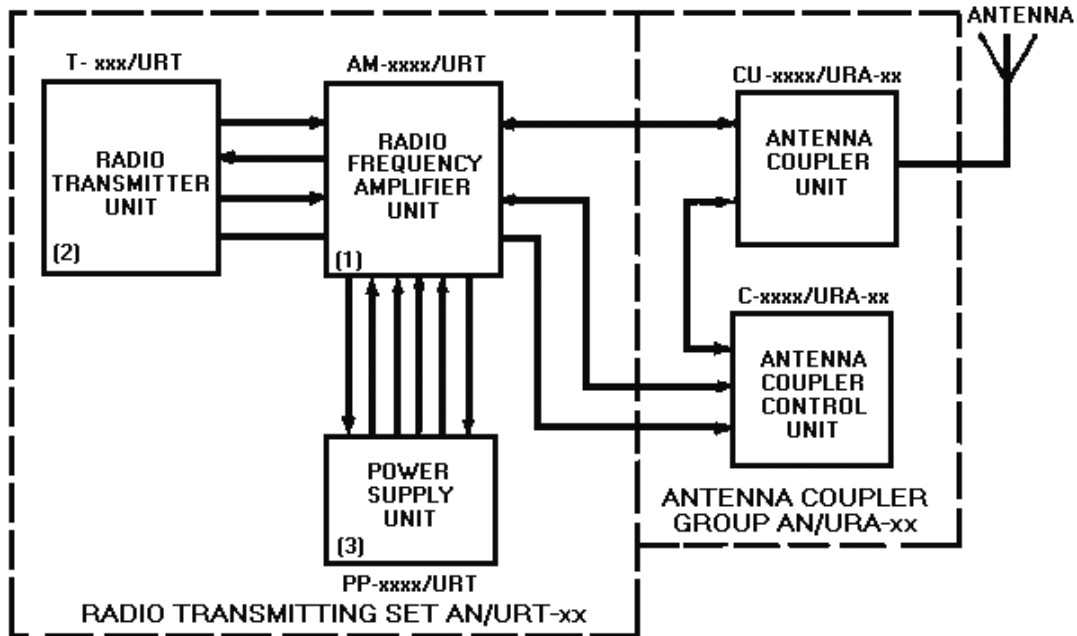

Figure 1-4.—Radio transmitting set.

Group

A GROUP is a collection of units, assemblies, subassemblies, and parts. It is a subdivision of a set or system, but it is not capable of performing a complete operational function. The coupler requires power and signals from the radiofrequency amplifier unit for operation. An example is the antenna coupler group in figure 1-4.

Unit

A UNIT is an assembly or any combination of parts, subassemblies, and assemblies mounted together. A unit is normally capable of independent operation in a variety of situations. An example of a unit might be a power supply.

Assembly

An ASSEMBLY is a number of parts or subassemblies, or any combination thereof, joined together to perform a specific function. Figure 1-5 shows a unit (2) with its six assemblies. The assembly (A6) contains six subassemblies.

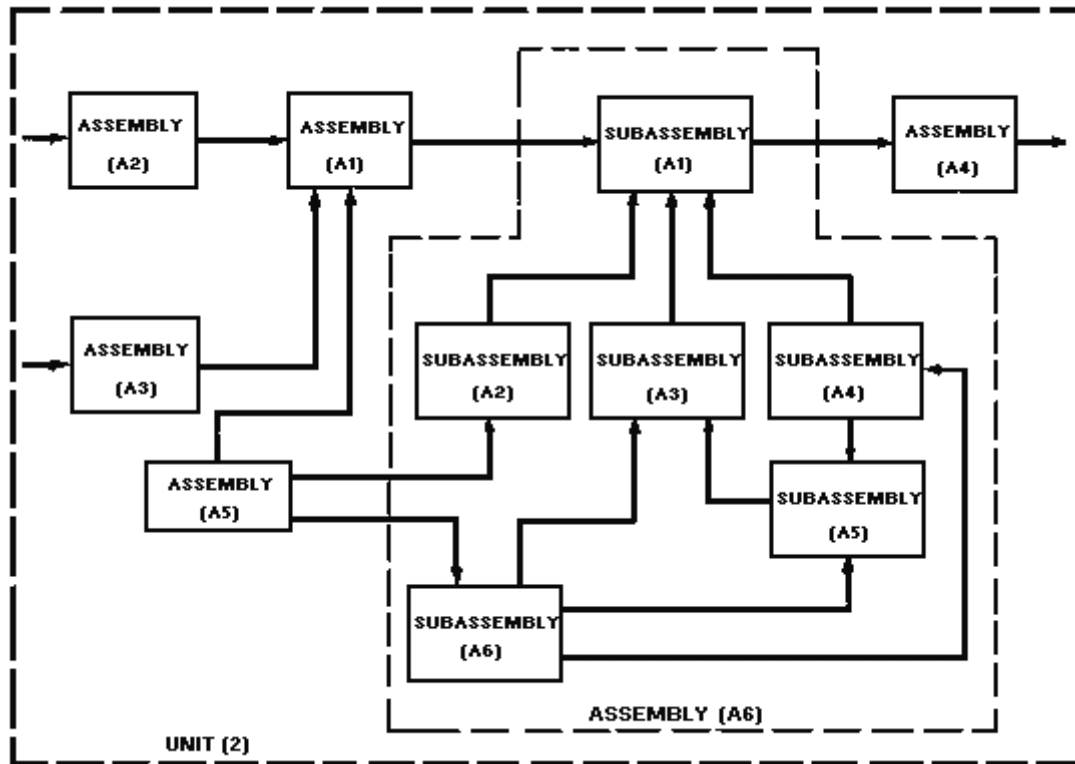

Figure 1-5.—Unit and assembly.

Subassembly

A SUBASSEMBLY consists of two or more parts that form a portion of an assembly or a unit. It is replaceable as a whole, but some of its parts are individually replaceable.

The distinction between an assembly and a subassembly is not always exact; an assembly in one application may be a subassembly in another when it forms a portion of an assembly. Figure 1-6 shows a printed circuit board subassembly and some of the parts which may be mounted on it.

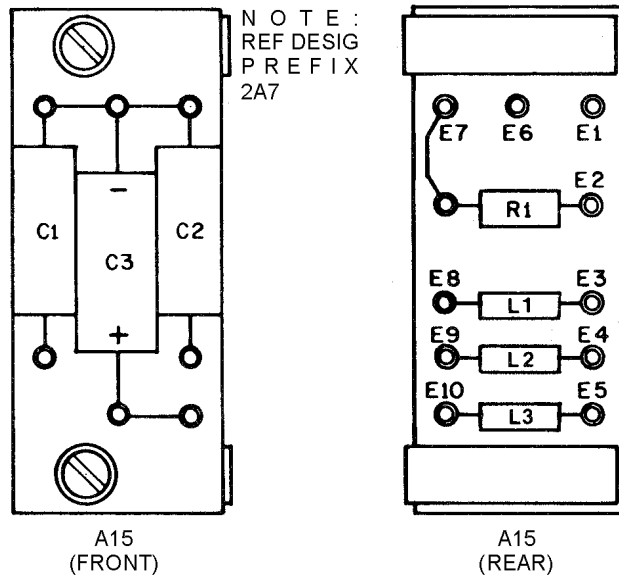

Figure 1-6.—Typical subassembly.

Part

A PART is one component or two or more components joined together. A part is not normally subject to disassembly without destruction. Resistors, capacitors, and transistors are examples of parts.

Reference Designations.

Reference designations consist of letters, numbers, or both and are used for identification purposes. Reference designations can be used in several different ways. One important way you will use them is as a cross-reference for locating supply stock numbers. When you know the reference designator, ordering the correct replacement for a failed component is easy. You will also use them frequently in corrective and preventive maintenance. Reference designators will help you to locate test points and adjustments; they will also help you to move back and forth between various technical manuals, schematics, tables, or other references.

Each set within a system is assigned an AN nomenclature. Each unit, assembly, subassembly, and part of a set has an assigned reference designation. Systems, sets, and groups have no reference designation. The unit is the highest level assigned a reference designator.

Each unit is assigned an identifying number. This number begins with the number 1 and runs consecutively for all units of a system or a set. Let's look back at the radio transmitting set AN/URT-xx with the unit numbers 1, 2, 3 on figure 1-4. You should note that these units may also have an AN nomenclature, such as T-xxx/URT. The T indicates the equipment is a transmitter. The xxx would be replaced by 3 digits that indicate the model number.

By examining the reference designator of a unit, you will be able to determine in which group, if any, the unit is contained. Let's look at a complete reference designator for a unit. A good example for us to break down is the reference designator 2A2A3C1 on figure 1-7.

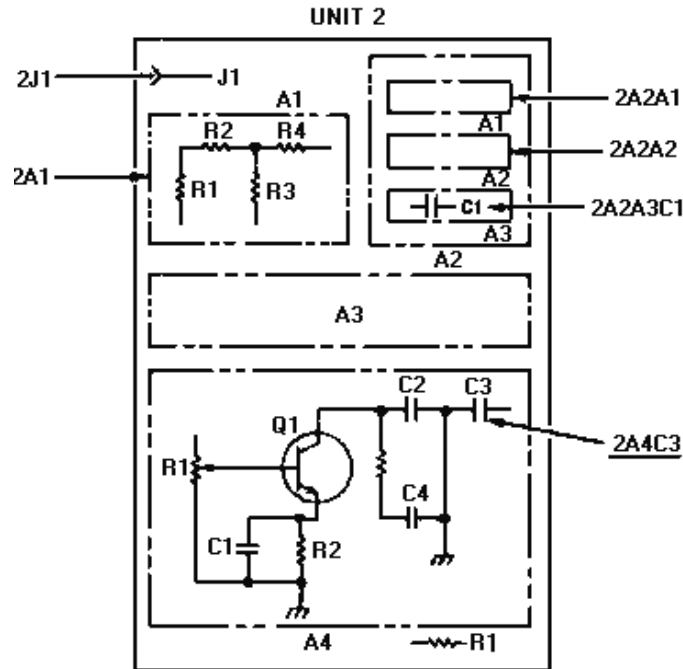

Figure 1-7.—Reference designations.

The first indicator, 2, is numeric and refers to unit 2. The next indicator, A2, is alphanumeric and refers to assembly A2. The next indicator, A3, is also alphanumeric and refers to subassembly A3. The last indicator, C1, like the two previous, is alphanumeric and refers to the part C1. We have just located capacitor C1 on subassembly A3, which is on assembly A2, which is in unit 2 of the equipment.

Reference designations may be expanded or reduced to as many levels as required to identify a particular part. Let's look at a couple of examples on our figure. The designator 2J1 identifies jack J1, which is mounted directly on unit 2. The designator 2A4C3 identifies capacitor C3, which is on assembly A4 in unit 2.

Partial reference designations are used to save space on diagrams. For example, refer back to figure 1-6. Partial reference designations are placed near the parts on subassembly A15, and a note indicates the reference designation prefix is added. Capacitor C3 on subassembly A15 has the complete reference designation 2A7A15C3.

Q7. A system is subdivided into what levels?

Q8. In the example 1A6CR3, what is the assembly designator?

NAVY FREQUENCY BAND USE

Rapid growth in the quantity and complexity of communications equipment and increased worldwide international requirements for radio frequencies have placed large demands upon the radio-frequency spectrum. These demands include military and civilian applications such as communications, location and ranging, identification, standard time and frequency transmission, and industrial, medical, and other scientific uses.

The allocation, assignment, and protection of all frequencies used by any component of the Navy are the responsibility of Commander Naval Telecommunications Command (COMNAVTELCOM). Table

1-1 shows the radio-frequency spectrum broken down into nine bands used by the military. Propagation of radio waves varies widely at different frequencies. Frequencies and equipment are chosen to meet the communications application desired. We will discuss the radio-frequency spectrum in the following paragraphs.

Table 1-1.—Radio-Frequency Spectrum

FREQUENCY	DESCRIPTION
30 GHZ - 300 GHZ	extremely high frequency
3 GHZ - 30 GHZ	superhigh frequency
300 MHZ - 3 GHZ	ultrahigh frequency
30 MHZ - 300 MHZ	very high frequency
3 MHZ - 30 MHZ	high frequency
300 KHZ - 3 MHZ	medium frequency
30 KHZ - 300 KHZ	low frequency
3 KHZ - 30 KHZ	very low frequency
300 HZ - 3 KHZ	voice frequency
Up to 300 HZ	extremely low frequency

Extremely Low-Frequency Communications

The purpose of the EXTREMELY LOW-FREQUENCY (elf) communications system is to send short "phonetic letter spelled out" (PLSO) messages from operating authorities in the continental United States (CONUS) to submarines operating at normal mission speeds and depths. Elf has the ability to penetrate ocean depths to several hundred feet with little signal loss. This ability allows submarines to be operated well below the immediate surface and enhances submarine survivability by making detection more difficult.

This is a one-way communications system from the operating authority to submarines at sea. The large size of elf transmitters and antennas makes elf transmission from submarines impractical.

Very-Low-Frequency Communications

The communications commitments of the Navy now cover the face of the earth. New sea frontiers to the north have opened a four-million-square-mile, ice-covered ocean of strategic importance. Our Navy must maintain control of the operating forces in an ever expanding coverage area. This additional area requires changes in communications capacity, range, and reliability. Additional needs have been particularly great in the North Atlantic and the newly opened Arctic Ocean. High-frequency circuits are too unreliable in these areas because of local atmospheric disturbances.

VERY-LOW-FREQUENCY (vlf) transmissions provide a highly reliable path for communications in these northern latitudes as well as over and under all oceans and seas of the world. At present, practically all Navy vlf transmitters are used for fleet communications or navigation. The vlf transmission is normally considered a broadcast, that is, one-way transmission, no reply required. The vlf transmitter normally transmits single-channel rtty.

Vlf is currently used for communications to large numbers of satellites and as a backup to shortwave communications blacked out by nuclear activity. Our Navy depends on vlf for crucial communications during hostilities.

Secondary applications of the vlf range include worldwide transmission of standard frequency and time signals. Standard frequency and time signals with high accuracy over long distances have become increasingly important in many fields of science. It is essential for tracking space vehicles, worldwide clock synchronization and oscillator calibration, international comparisons of atomic frequency standards, radio navigational aids, astronomy, national standardizing laboratories, and communications systems.

A vlf broadcast of standard time and frequency signals has more than adequate precision for the operation of synchronous cryptographic devices, decoding devices, and single-sideband transmissions.

Low-Frequency Communications

The LOW-FREQUENCY (lf) band occupies only a very small part of the radio-frequency spectrum. This small band of frequencies has been used for communications since the advent of radio.

Low-frequency transmitting installations are characterized by their large physical size and by their high construction and maintenance costs. Another disadvantage is low-frequency signal reception being seriously hampered by atmospheric noise, particularly at low geographical latitudes. Over the years, propagation factors peculiar to the low-frequency band have resulted in their continued use for radio communications. Low-frequency waves are not so seriously affected during periods of ionospheric disturbance when communications at the high frequencies are disrupted. Because of this, the Navy has a particular interest in the application of low frequencies at northern latitudes.

The Navy's requirement to provide the best possible communications to the fleet requires operation on all frequency bands. Constant research is being done to improve existing capabilities and to use new systems and developments as they become operationally reliable.

In the past, the fleet broadcast system provided ships at sea with low-frequency communications via cw telegraph transmissions. As technology advanced, the system was converted to single-channel radio teletypewriter transmission. Today lf communications is used to provide eight channels of frequency-division multiplex rtty traffic on each transmission of the fleet multichannel broadcast system.

Medium-Frequency Communications

The MEDIUM-FREQUENCY (mf) band of the radio-frequency spectrum includes the international distress frequencies (500 kilohertz and approximately 484 kilohertz). Some ships have mf equipment. If desired the distress frequencies may be monitored. When this is done the transmitter usually is kept in the standby position. Ashore, the mf receiver and transmitter equipment configuration is usually affiliated with search and rescue organizations, which are generally located near the coast.

Only the upper and lower ends of the mf band have naval use because of the commercial broadcast band (AM) extending from 535 to 1,605 kilohertz. Frequencies in the lower portion of the mf band (300 to 500 kilohertz) are used primarily for ground-wave transmission for moderately long distances over

water and for moderate to short distances over land. Transmission in the upper mf band is generally limited to short-haul communications (400 miles or less).

High-Frequency Communications

The Navy began using HIGH FREQUENCIES for radio communications around World War I when only a few communications systems were operated on frequencies near 3 megahertz. When we look at the extensive present-day use of high frequencies for long-distance communications, the fact that those Navy systems were intended for very short-range communications of a few miles seems curious. The general belief at the time was that frequencies above 1.5 megahertz were useless for communications purposes.

One of the prominent features of high-frequency, long-distance communications is the variable nature of the propagation medium. (You studied this in NEETS, Module 10, *Introduction to Wave Propagation, Transmission Lines, and Antennas*). Successful transmission of hf signals over a long distance is dependent upon refraction of radio waves by layers of the ionosphere. The height and density of these layers is formed mainly by ultraviolet radiation from the sun. They vary significantly with the time of day, season of the year, and the eleven-year cycle of sunspot activity. Because of these variations, you must generally use more than a single frequency, sometimes up to four or five, to maintain communications on a circuit.

In spite of the difficulties we encounter with hf propagation, the economic and technical advantages of using high frequencies have led to rapid expansion of the use of the hf band. Because the number of users has increased, the hf spectrum is approaching saturation.

The hf band is shared by many domestic and foreign users, and only portions scattered throughout the band are allocated to the military services. Like other agencies, Navy requirements have grown; the capacity of the Navy's assigned portion of the hf spectrum has become severely taxed. The use of single-sideband equipment and the application of independent sideband techniques have increased the capacity, but not enough to catch up with the demand. Some predict that satellite communications will eventually relieve congestion in the hf band and that, for some types of service, it will replace hf for long-distance communications. We will present more information to you concerning satellite communications in chapter 3. Even with new technology the hf spectrum most likely will continue to be in high demand for some time.

Naval communications within the hf band can be grouped into four general types of services: point-to-point, ship-to-shore, ground-to-air, and fleet broadcast. All but the fleet broadcast are normally operated with two-way communications. Some of these services involve ships and aircraft that present special problems because of their physical characteristics and mobility. Generally, the less than optimum hf performance of this shipboard equipment is at least partially offset by powerful transmitters and sensitive receiving systems at the shore terminals.

POINT-TO-POINT.—Point-to-point systems are established to communicate over long-distance trunks or links between fixed terminals. A trunk is normally a message circuit between two points that are both switching centers or individual message distribution points. A link is a transmitter-receiver system connecting two locations.

Generally, enough real estate is acquired at the terminals to permit the use of large, high-gain antennas aimed at opposite terminals of each link. This increases the effective radiated power and the sensitivity of the receiving system; it also reduces susceptibility of a circuit to interference.

With the path length and direction fixed, other propagation factors are simplified and highly reliable communications can be achieved.

SHIP-TO-SHORE.—This application of the hf band is more difficult than point-to-point since the ship is moving and constantly changing its position. In ship-to-shore the path length and direction are variable. Aboard ship, limited space and other restrictions prohibit installation of large, efficient hf antennas. Because of the mobility of ships, shipboard antennas are designed to be as nearly omnidirectional as possible.

Our problems are not as severe at the shore terminal where we have sufficient space for efficient omnidirectional antennas or arrays designed for coverage of large areas of the earth. At shore stations, rotatable, high-gain antennas or fixed, point-to-point antennas are used. For example, a rhombic antenna ashore may work well for long-haul, ship-to-shore communications when the ship is within range of the antenna.

Several frequencies are usually assigned for each circuit. Therefore, a frequency can be selected that best matches the propagation path conditions between the shore terminal and the ship.

GROUND-TO-AIR.—The use of hf radio for ground-to-air communications is similar to ship-to-shore. The only exception is an aircraft moves more rapidly than a ship. All major circuit improvements must be made at the ground station. For example, higher powered transmitters, lower noise receivers, and more efficient antennas must be used on the ground.

FLEET BROADCASTS.—As the name implies, this service involves broadcast area coverage from shore-based transmitters to ships at sea. Messages to be sent to ships are delivered by various means to the proper broadcast station. They are then broadcast for shipboard reception. To overcome propagation problems, naval communicators send the messages on several frequencies at once. This is known as frequency-diversity transmission. This type of transmission allows the ship to choose the best frequency for reception. Space-diversity with physically separated receive antennas also helps to overcome this problem.

Very-High-Frequency and Above Communications

Frequencies above 30 megahertz are not normally refracted by the atmosphere and ground-wave range is minimal. This normally limits our use of this frequency spectrum to line of sight. The exception to this is increased range through the use of tropospheric scatter techniques. Some communications using vhf and above frequencies use a technique called forward propagation by tropospheric scatter (fpts). This method will be discussed in more detail in chapter 5.

Certain atmospheric and ionospheric conditions can also cause the normal line-of-sight range to be extended. Frequencies at the lower end of this band are capable of overcoming the shielding effects of hills and structures to some degree; but as the frequency is increased, the problem becomes more pronounced. Reception is notably free from atmospheric and man-made static. (The VERY-HIGH-FREQUENCY (vhf) and ULTRAHIGH-FREQUENCY (uhf) bands are known as line-of-sight transmission bands.) Because this is line-of-sight communications, the transmitting antenna is in a direct line with the receiving antenna and not over the horizon. The line-of-sight characteristic makes the vhf band ideal for amphibious operations (beach landing from sea craft) and the uhf well suited for tactical voice transmissions (maneuvering of ships traveling together). The SUPERHIGH-FREQUENCY (shf) band is used for radar and satellite communications, whereas the EXTREMELY HIGH-FREQUENCY (ehf) band is used only in the experimental stage.

Q9. The majority of vlf transmitters are used for what purpose?

Q10. Today the Navy uses hf communications as a segment of what operational system?

Q11. Why does the Navy only use the upper and lower ends of the mf band?

Q12. What are the four general types of communications services in the hf band?

Q13. A message transmitted on several frequencies at the same time is an example of what type of transmission?

Q14. Physically separating receive antennas is an example of what technique?

Q15. When using frequencies above 30 megahertz, you are normally limited to using what range?

COMMUNICATIONS FUNDAMENTALS

Now that we have learned the Navy's fundamental use of the various frequency bands, we should look at the types of communications links and their modes of operation. The Navy uses many modes of operation; the type used is based upon the function of the circuit or network. These modes (or functions) are combined to form a communications link. We will also discuss some of the actual networks the Navy uses on a daily basis.

COMMUNICATIONS LINKS

A complex of links forms a major communications system. The naval communications system is broken down into strategic and tactical groups.

Strategic

Strategic communications are generally world-wide in nature. They are operated on a common-user (Navy, Army, Department of Defense, and so on) or special-purpose basis. A strategic system may be confined within a specified area or limited to a specific type of traffic, but the configuration is designed so that combined operations with other strategic systems are possible. As an example, we will look at the automatic voice network, automatic digital network, and the defense special security communications system later in this chapter.

Tactical

Tactical communications are usually limited to a specific area of operations and are used to direct or report the movement of specific forces. Some tactical networks are used only for operational traffic; others may be used for operational and administrative traffic. For instance, the task force, task-group, and air-control networks are ordinarily used for operational traffic. Ship-to-shore networks and broadcast networks serve both types of traffic.

Modes of Operation

Communications links have numerous modes of operation. In our discussion, a mode of operation is identified as a link or path between two or more points that is capable of providing one or more channels for the transmission of intelligence. Let's take a look at the five most common modes of operation.

SIMPLEX.—The simplex (splx) mode uses a single channel or frequency to exchange information between two or more terminals. Communications is in one direction only.

HALF DUPLEX.—The half-duplex (hdx) mode has one-way flow of information between terminals. Technical arrangements often permit transmission in either direction, but not simultaneously. This term must be qualified to show s/o (send only), r/o (receive only), or s/r (send or receive).

SEMIDUPLEX.—The semiduplex (sdx) uses an arrangement of equipment where one terminal is simplex configured and the other uses two channels or frequencies in full duplex. A clarifying example is

a ship in a simplex mode terminated full duplex with a shore station. The ship may send or receive but not do both at the same time.

FULL DUPLEX.—The full-duplex (fdx) mode is a method of operation in which telecommunications between stations takes place simultaneously in both directions using two separate frequencies. In other words, a ship may send and receive different messages at the same time. The term "full duplex" is synonymous with "duplex."

BROADCAST.—Broadcast (bc) is the type of operation in which one station transmits information on one or more channels directed to more than one station and/or unit. The broadcast system has no provision for receipt or reply; however, special arrangements may require the receiving station to reply or receipt for the message at a later time by other means. Broadcasts are the primary means of delivering messages to the fleet. Since Navy units copying broadcasts are not required to receipt for messages received, they can maintain radio silence while still receiving essential messages.

Message traffic is normally sent to the fleet by three methods: broadcast, intercept, and receipt. The first two are "do not answer" methods; the third, as its name implies, requires a receipt from the addressee (addee) for each message. Broadcast and intercept methods allow the fleet to preserve radio silence, which is a great advantage from the standpoint of security. By the intercept method, a shore radio station transmits messages to another shore station that repeats them back. Ships intercept and copy all of this message traffic.

Broadcast is preferable to intercept chiefly because it is faster. It is the method by which nearly all fleet traffic is handled. It uses radiotelegraph, radiotelephone, radio teletypewriter, and facsimile.

There is some similarity between civilian and naval broadcasts. Just as commercial stations in the broadcast band transmit programs to radio receivers in the homes in their communities, Navy communications stations broadcast messages to fleet units in their particular geographic areas. The resemblance between Navy and commercial stations ceases there. Information broadcast by naval communications stations is contained in chronologically numbered messages addressed to the ships. The messages are copied by the fleet units, which check the serial numbers to ensure they have a complete file. This checks and balances system ensures the ship has not missed any of the broadcast message traffic.

Fleet broadcasts follow regular schedules. Messages are placed on the schedules in order of precedence. If a message of higher precedence is given to a transmitter station while a lower precedence message is being transmitted, the latter message may be interrupted to transmit the message of higher precedence. All ships copy all messages appearing on the broadcast schedule they are guarding.

Messages are normally transmitted on several frequencies to make sure they are received. This gives the receiving station the choice of frequency selection when considering time of day and atmospheric conditions for best reception.

Q16. The naval communications system is made up of what two groups of communications?

Q17. What are the five most prominent communications modes of operation?

SWITCHED NETWORKS

The defense communications system (DCS) is composed of all worldwide, long-haul, government-owned and leased point-to-point circuits, trunks, terminals, switching centers, control facilities, and tributaries of military departments and other defense activities. In essence the DCS combines into a single

system all the elements that make up the naval communications system and the Army and Air Force equivalent.

The switched networks discussed in this section, automatic voice network, automatic secure voice communications, automatic digital network, and the defense special security communications system, are part of the DCS and are managed by the Defense Communications Agency (DCA). You should not confuse these DCS networks with the HICOM (high-command communications network) and NORATS (Navy operational radio and telephone switchboard) networks. We will discuss both of these Navy-only networks later in this chapter.

Automatic Voice Network (AUTOVON)

The DCS AUTOVON offers rapid, direct interconnection of DOD and certain other government installations through worldwide telephone exchanges. AUTOVON is a worldwide, general-purpose direct dialing telephone system. The goal of the AUTOVON system is to complete connections between two points anywhere in the world in about two seconds and to complete regular connections with push-button speed.

The AUTOVON system is made up of several installations comparable in function to commercial telephone exchanges. An installation is referred to as an AUTOVON switch, or simply switch. Within individual areas we have local command, control, and administrative voice communications systems. These systems connect into the worldwide AUTOVON through manually operated telephone switchboards or automatic dial exchanges by using direct in and out dialing.

Normal AUTOVON service allows your station to call other stations on a worldwide basis for day-to-day communications by using the telephone.

Automatic Secure Voice Communications (AUTOSEVOCOM)

Another close relative to the AUTOVON system is the AUTOSEVOCOM a worldwide, switched telephone network. It provides authorized users with a means for exchanging classified information over communications security (COMSEC) circuitry or over other approved circuitry. The system consists of both manual and automated networks within a single system.

For subscribers to the AUTOSEVOCOM network, telephone directories containing subscriber listings, general instructions for placing calls, and trouble-reporting procedures are provided.

Automatic Digital Network (AUTODIN)

The DCS AUTODIN is a fully automatic, digital system. The system converts word messages to digital form for transmission.

AUTODIN is used to furnish instantaneous, error-free, and secure communications around the world to several thousand directly connected subscriber terminals. Daily capacity of the system is about five-million average-length messages.

AUTODIN switching centers are interconnected through a network of high-frequency radio channels, submarine cables, microwave and tropospheric channels, and a variety of wire lines.

The whole concept of AUTODIN is to reduce manual handling of messages to a minimum by the use of automated equipment. This system has reduced message delivery times and delay anywhere in the world to a matter of seconds rather than minutes or hours.

Defense Special Security Communications System (DSSCS)

The defense special security communications system (DSSCS) was established for the purpose of integrating the critical intelligence communications (CRITICOMM) and the special intelligence communications (SPINTCOMM) networks into a single automated communications network. In effect, the integration of DSSCS subscribers into AUTODIN provides two separate systems within AUTODIN—one system for special intelligence (SI) message traffic and the other for the AUTODIN regular message traffic.

NAVY-ONLY NETWORKS

Some networks are used by the Navy only. As mentioned previously, these are the high command communications network (HICOM) and the Navy operational radio and telephone switchboard (NORATS) networks. Let's look at some of their functions and purposes.

High Command Communications Network (HICOM)

The HICOM network provides a voice link between the Chief of Naval Operations (CNO) and all subordinate commands ashore, afloat, and airborne. CNO is the master control station and each fleet commander in chief has an area network control station. All naval communications stations are members.

In cases where a fleet unit is suffering communications difficulties with normal channels, HICOM is used on a not-to-interfere basis to restore communications. All naval communications stations are required to guard HICOM for their respective area networks and use this system.

Navy Operational Radio and Telephone Switchboard (NORATS)

The NORATS meets our need for a connection between Navy tactical voice systems of the operating forces and the various fixed telephone services ashore. This system extends tactical voice to shore-based operational commands. NORATS provides a connecting point in the fleet center of each communication station. This point allows us to connect or patch all ship-to-shore voice circuits and designated local shore telephone systems and extensions. A combined HICOM/NORATS console exists at many naval communications stations.

Q18. What four switched networks are part of the defense communications system?

Q19. What two elements support only designated Navy requirements?

SUMMARY

Now that you have completed this chapter, a short review of what you have learned is in order. The following summary will refresh your memory of radio-frequency communications terms.

TELECOMMUNICATIONS refers to transmission, emission, or reception of signs, signals, writings, images, or sounds. This is done by visual, oral, wire, radio, or other electromagnetic means.

RADIO COMMUNICATIONS is the term describing teletypewriter, voice, telegraphic, and facsimile communications.

SYSTEM is a combination of sets, units, assemblies, subassemblies, and parts joined together to form a specific operational function or several functions.

SET is a unit or units and the assemblies, subassemblies, and parts connected or associated together to perform a specific function.

GROUP is a collection of units, assemblies, subassemblies, and parts. It is a subdivision of a set or system but is not capable of performing a complete operational function.

UNIT is an assembly or any combination of parts, subassemblies, and assemblies mounted together. Normally capable of independent operation.

ASSEMBLY is a number of parts or subassemblies, or any combination thereof, joined together to perform a specific function.

SUBASSEMBLY consists of two or more parts that form a portion of an assembly or a unit.

PART is one component or two or more components joined together. It is not normally subject to disassembly without destruction.

EXTREMELY LOW FREQUENCY is the band of frequencies up to 300 hertz.

VERY LOW FREQUENCY is the band of frequencies from 3 kilohertz to 30 kilohertz.

LOW FREQUENCY is the band of frequencies from 30 kilohertz to 300 kilohertz.

MEDIUM FREQUENCY is the band of frequencies from 300 kilohertz to 3 megahertz.

HIGH FREQUENCY is the band of frequencies from 3 megahertz to 30 megahertz.

VERY HIGH FREQUENCY is the band of frequencies from 30 megahertz to 300 megahertz.

ULTRAHIGH FREQUENCY is the band of frequencies from 300 megahertz to 3 gigahertz.

SUPERHIGH FREQUENCY is the band of frequencies from 3 gigahertz to 30 gigahertz.

EXTREMELY HIGH FREQUENCY is the band of frequencies from 30 gigahertz to 300 gigahertz.

ANSWERS TO QUESTIONS Q1. THROUGH Q19.

- A1. Radio and wire.*
- A2. Reliability.*
- A3. It is direct, convenient and easy to use.*
- A4. Static, enemy interference or a high local noise level.*
- A5. High speed automatic communications across ocean areas.*
- A6. The process used to transmit photographs, charts and other graphic information electronically.*
- A7. Set, group, unit, assembly, subassembly, and part.*
- A8. A6.*
- A9. Fleet communications or navigation.*
- A10. Fleet Multichannel Broadcast System.*
- A11. Due to the commercial broadcast (AM) band.*
- A12. Point-to-point, ship-to-shore, ground-to-air, and fleet broadcast.*
- A13. Frequency-diversity.*
- A14. Space-diversity.*
- A15. Line of sight.*
- A16. Strategic and tactical.*
- A17. Simplex, half-duplex, semiduplex, duplex, and broadcast.*
- A18. AUTOVON, AUTOSEVOCOM, AUTODIN, and DSSCS.*
- A19. HICOM and NORATS.*

CHAPTER 2

INTRODUCTION TO COMMUNICATIONS THEORY

LEARNING OBJECTIVES

Upon completion of this chapter you will be able to:

1. Describe the four basic types of transmitters.
2. Describe the two basic types of single-sideband circuits.
3. Describe the three basic types of teletypewriter circuits.
4. List the four primary functions of a basic receiver.
5. Describe the four primary functions of a basic receiver.
6. State the four characteristics of a basic receiver.
7. Evaluate the four characteristics of a basic receiver.
8. Describe the fundamental heterodyning process.
9. Describe the basic difference between an AM and an fm receiver.
10. Describe single-sideband suppressed carrier communications.
11. State the purpose of carrier reinsertion and how it is used in single-sideband communications.
12. Describe the basic theory and functions of receiver control circuits.
13. Describe the basic frequency synthesis process.
14. Describe the basic audio reproduction process.

INTRODUCTION

In the previous chapter you learned the fundamentals of U.S. naval telecommunications and communications. Now, let's look at the equipment and systems that are used to communicate in the Navy. The fundamental equipment used to communicate are the transmitter and receiver.

Transmitters and receivers must each perform two basic functions. The transmitter must generate a radio frequency signal of sufficient power at the desired frequency. It must have some means of varying (or modulating) the basic frequency so that it can carry an intelligible signal. The receiver must select the desired frequency you want to receive and reject all unwanted frequencies. In addition, receivers must be able to amplify the weak incoming signal to overcome the losses the signal suffers in its journey through space.

Representative transmitters and their fundamental features are described for you in this module.

TRANSMITTER FUNDAMENTALS

Basic communication transmitters include continuous wave (cw), amplitude modulated (AM), frequency modulated (fm), and single sideband (ssb) types. A basic description of each of these transmitters is given in this chapter.

CONTINUOUS WAVE TRANSMITTER

The continuous wave is used principally for radiotelegraphy; that is, for the transmission of short or long pulses of rf energy to form the dots and dashes of the Morse code characters. This type of transmission is sometimes referred to as interrupted continuous wave. Cw transmission was the first type of radio communication used, and it is still used extensively for long-range communications. Two of the advantages of cw transmission are a narrow bandwidth, which requires less output power, and a degree of intelligibility that is high even under severe noise conditions. (For example, when the receiver is in the vicinity of rotating machinery or thunderstorms.)

A cw transmitter requires four essential components. These are a *generator*, *amplifier*, *keyer*, and *antenna*. We have to generate rf oscillations and have a means of amplifying these oscillations. We also need a method of turning the rf output on and off (keying) in accordance with the intelligence to be transmitted and an antenna to radiate the keyed output of the transmitter.

Let's take a look at the block diagram of a cw transmitter and its power supply in figure 2-1. The oscillator generates the rf carrier at a preset frequency and maintains it within close tolerances. The oscillator may be a self-excited type, such as an electron-coupled oscillator, or a quartz crystal type, which uses a crystal cut to vibrate at a certain frequency when electrically excited. In both types, voltage and current delivered by the oscillator are weak. The oscillator outputs must be amplified many times to be radiated any distance.

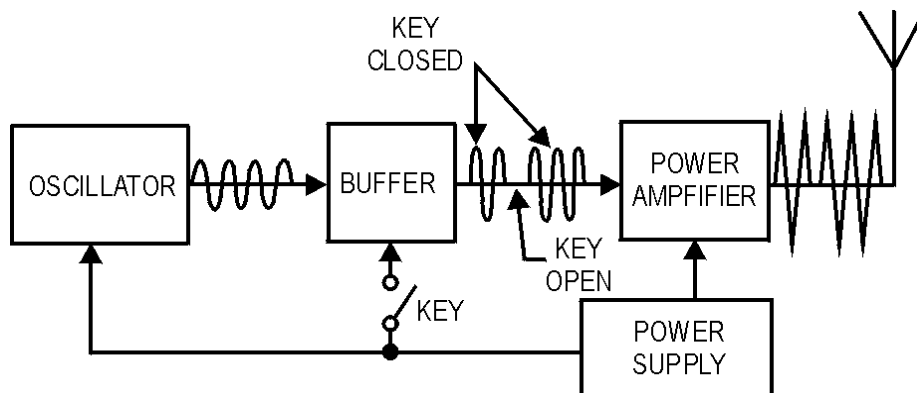

Figure 2-1.—Cw transmitter block diagram.

The buffer stage or first intermediate power amplifier stage (referred to as the ipa) is a voltage amplifier that increases the amplitude of the oscillator signal to a level that drives the power amplifier (pa). You will find the signal delivered by the buffer varies with the type of transmitter and may be hundreds or thousands of volts.

The buffer serves two other purposes. One is to isolate the oscillator from the amplifier stages. Without a buffer, changes in the amplifier caused by keying or variations in source voltage would vary the load of the oscillator and cause it to change frequency. It may also be used as a frequency multiplier, which is explained later in this text.

As you can see in the figure, a key is used to turn the buffer on and off. When the key is closed, the rf carrier passes through the buffer stage; when the key is open (buffer is turned off), the rf carrier is prevented from getting through.

The final stage of a transmitter is the power amplifier (referred to as the pa). In chapter 3 of NEETS, Module 1, *Introduction to Matter, Energy, and Direct Current*, you learned that power is the product of current and voltage ($P = IE$). In the power amplifier a large amount of rf current and voltage is made available for radiation by the antenna.

The power amplifier of a high-power transmitter may require far more driving power than can be supplied by an oscillator and its buffer stage. One or more low-power intermediate amplifiers are used between the buffer and the final amplifier that feeds the antenna. The main difference between many low- and high-power transmitters is in the number of intermediate power-amplifier stages used.

Figure 2-2 is a block diagram of the input and output powers for each stage of a typical medium-power transmitter. You should be able to see that the power output of a transmitter can be increased by adding amplifier stages capable of delivering the power required. In our example, the .5 watt output of the buffer is amplified in the first intermediate amplifier by a factor of 10, (this is a times 10 [$\times 10$] amplifier) giving us an input of 5 watts to the second intermediate amplifier. You can see in this example the second intermediate amplifier multiplies the 5 watt input to it by a factor of 5 ($\times 5$) and gives us a 25 watt input to our power (final) amplifier. The final amplifier multiplies its input by a factor of 20 ($\times 20$) and gives us 500 watts of power out to the antenna.

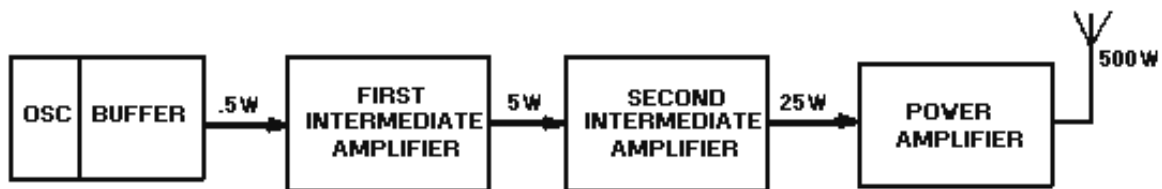

Figure 2-2.—Intermediate amplifiers increase transmitter power.

- Q1. What are the four basic transmitter types?
- Q2. What is the function of the oscillator in a cw transmitter?
- Q3. What is the final stage of a transmitter?

AMPLITUDE MODULATED TRANSMITTER

In AM transmitters, the instantaneous amplitude of the rf output signal is varied in proportion to the modulating signal. The modulating signal may consist of many frequencies of various amplitudes and phases, such as the signals making up your own speech pattern.

Figure 2-3 gives you an idea of what the block diagram of a simple AM transmitter looks like. The oscillator, buffer amplifier, and power amplifier serve the same purpose as those in the cw transmitter. The microphone converts the audio frequency (af) input (a person's voice) into corresponding electrical energy. The driver amplifies the audio, and the modulator further amplifies the audio signal to the amplitude necessary to fully modulate the carrier. The output of the modulator is applied to the power

amplifier. The pa combines the rf carrier and the modulating signal in the power amplifier to produce the amplitude-modulated signal output for transmission. In the absence of a modulating signal, a continuous rf carrier is radiated by the antenna.

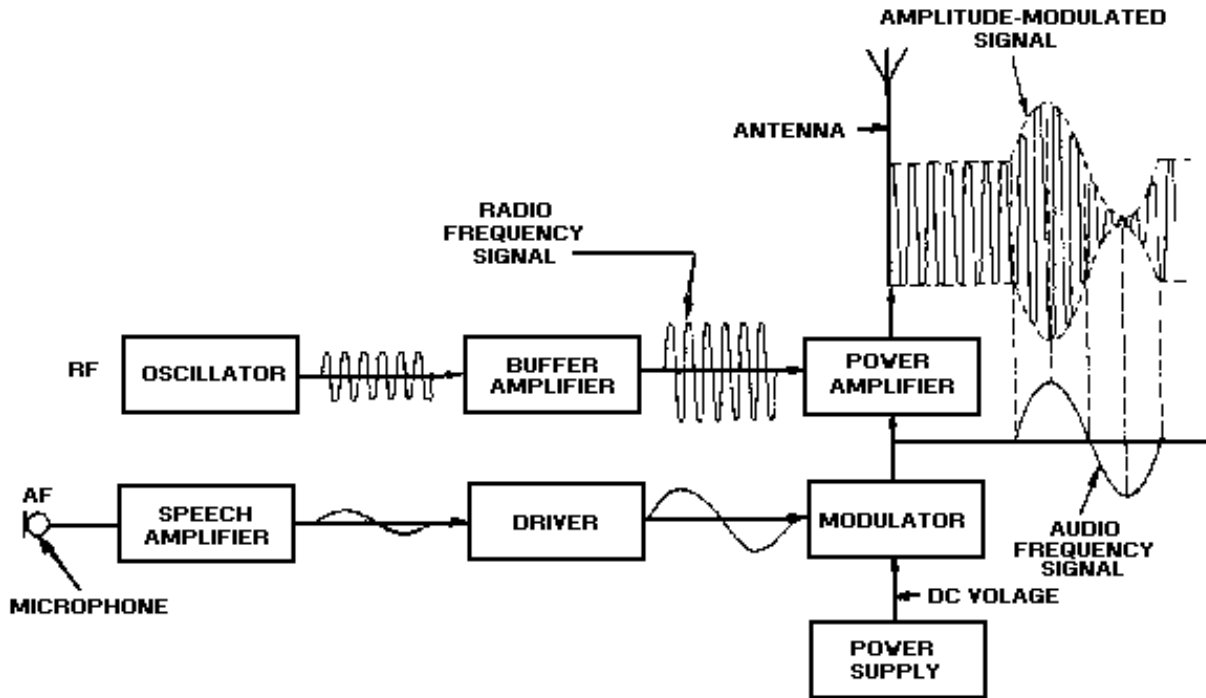

Figure 2-3.—AM radiotelephone transmitter block diagram.

FREQUENCY MODULATED TRANSMITTER

In frequency modulation (fm) the modulating signal combines with the carrier to cause the frequency of the resultant wave to vary with the instantaneous amplitude of the modulating signal.

Figure 2-4 shows you the block diagram of a frequency-modulated transmitter. The modulating signal applied to a varicap causes the reactance to vary. The varicap is connected across the tank circuit of the oscillator. With no modulation, the oscillator generates a steady center frequency. With modulation applied, the varicap causes the frequency of the oscillator to vary around the center frequency in accordance with the modulating signal. The oscillator output is then fed to a frequency multiplier to increase the frequency and then to a power amplifier to increase the amplitude to the desired level for transmission.

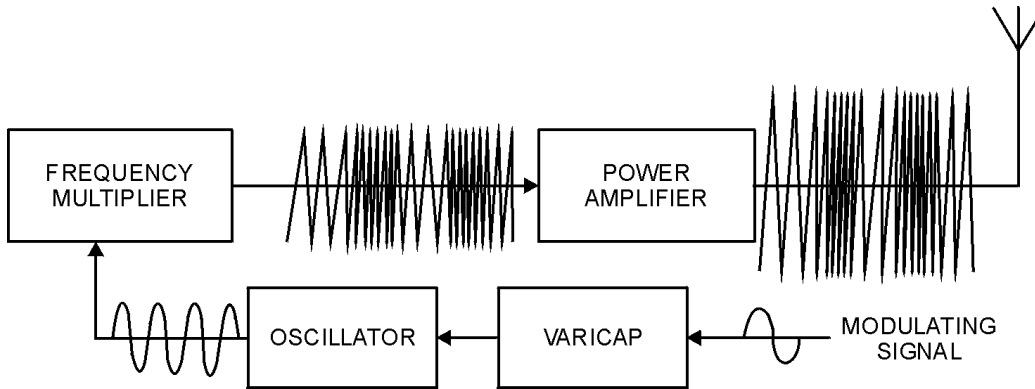

Figure 2-4.—Fm transmitter block diagram.

Harmonics

True harmonics are always exact multiples of the basic or fundamental frequency generated by an oscillator and are created in amplifiers and their associated circuits. Even harmonics are 2, 4, 6, and so on, times the fundamental; odd harmonics are 3, 5, 7, and so on, times the fundamental. If an oscillator has a fundamental frequency of 2,500 kilohertz, the harmonically related frequencies are

5,000.....	second harmonic
7,500.....	third harmonic
10,000.....	fourth harmonic
12,500.....	fifth harmonic

You should note that the basic frequency and the first harmonic are one and the same.

The series ascends indefinitely until the intensity is too weak to be detected. In general, the energy in frequencies above the third harmonic is too weak to be significant.

In some electronics books, and later in this chapter, you will find the term SUBHARMONIC used. It refers to a sine wave quantity (for example, an oscillator output) that has a frequency that is a submultiple of the frequency of some other sine wave quantity it helped make. For example, a wave that is half the fundamental frequency of another wave is called the second subharmonic of that wave; one with a third of the fundamental frequency is called a third subharmonic; and so forth.

- Q4. What purpose does a microphone perform in an AM transmitter?*
- Q5. In an fm transmitter, when does an oscillator generate only a steady frequency?*
- Q6. What is a harmonic?*
- Q7. If the fundamental frequency is 200 megahertz, what is the third harmonic?*

Frequency Multiplication

Designing and building a stable crystal oscillator is difficult. As operating frequencies increase, the crystal must be ground so thin that it often cracks while vibrating. You will find that you can get around this problem by operating the oscillators in most transmitters at comparatively low frequencies, sometimes as low as 1/100 (.01) of the output frequency. You raise the oscillator frequency to the required output frequency by passing it through one or more frequency multipliers. Frequency multipliers are special power amplifiers that multiply the input frequency. Stages that multiply the frequency by 2 are called doublers; those that multiply by 3 are triplers; and those multiplying by 4 are quadruplers.

You will find the main difference between low-frequency and high-frequency transmitters is the number of frequency-multiplying stages used. Figure 2-5 shows the block diagram of the frequency-multiplying stages of a typical Navy uhf/vhf transmitter. The oscillator in this transmitter is tunable from 18 megahertz to 32 megahertz. You have multiplier stages that increase the oscillator frequency by a factor of 12 through successive multiplications of 2, 2, and 3.

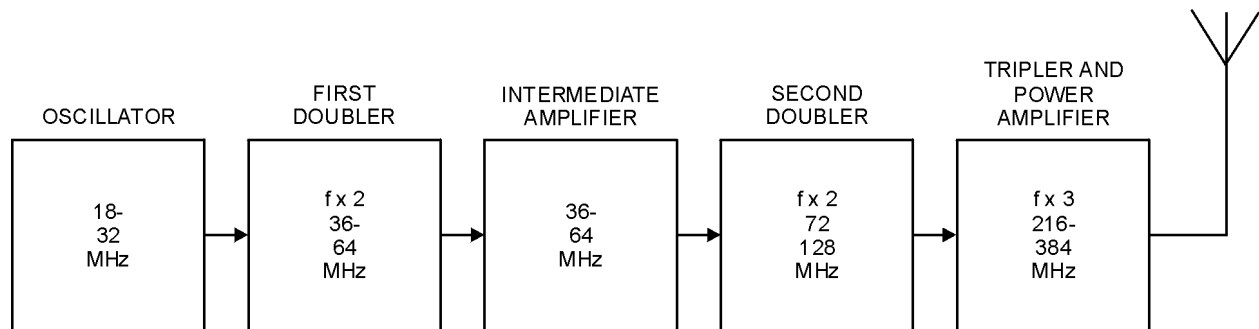

Figure 2-5.—Frequency multiplying stages of a typical vhf/uhf transmitter.

Figure 2-6 is a block diagram of an fm transmitter showing waveforms found at various test points. In high-power applications you often find one or more intermediate amplifiers added between the second doubler and the final power amplifier.

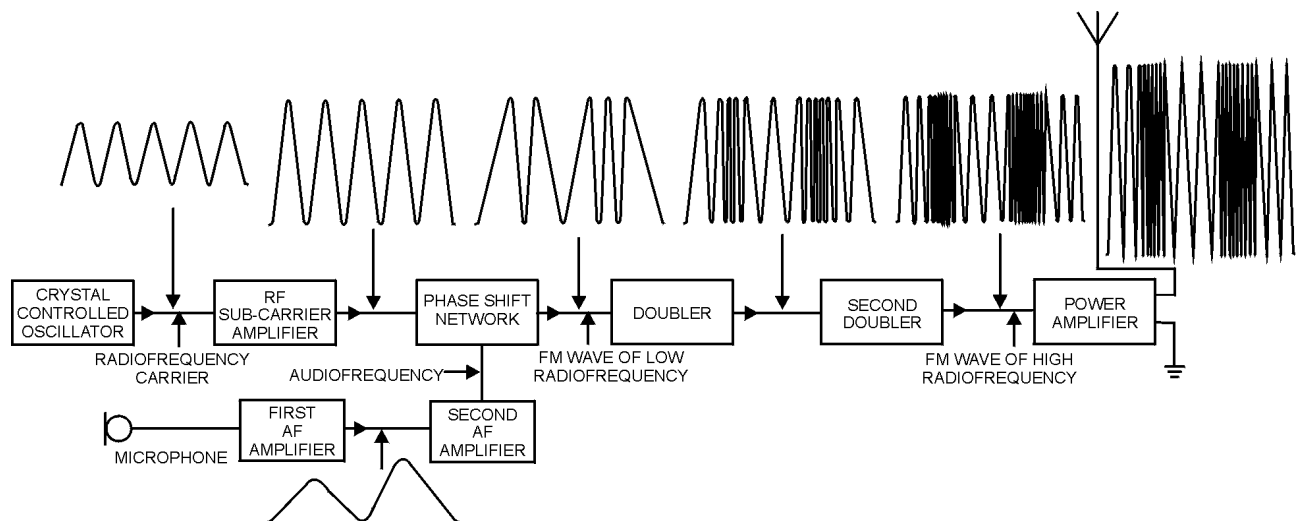

Figure 2-6.—Block diagram of an fm transmitter and waveforms.

SINGLE-SIDEBAND TRANSMITTER

You should remember the properties of modulation envelopes from your study of NEETS, Module 12, *Modulation Principles*. A carrier that has been modulated by voice or music is accompanied by two identical sidebands, each carrying the same intelligence. In amplitude-modulated (AM) transmitters, the carrier and both sidebands are transmitted. In a single-sideband transmitter (ssb), only one of the sidebands, the upper or the lower, is transmitted while the remaining sideband and the carrier are suppressed. SUPPRESSION is the elimination of the undesired portions of the signal.

Figure 2-7 is the block diagram of a single-sideband transmitter. You can see the audio amplifier increases the amplitude of the incoming signal to a level adequate to operate the ssb generator. Usually the audio amplifier is just a voltage amplifier.

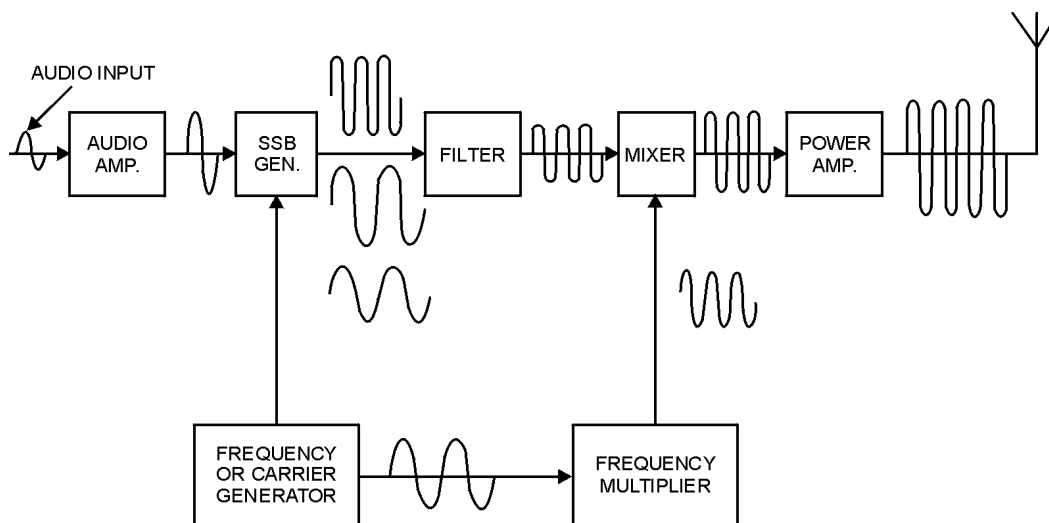

Figure 2-7.—Ssb transmitter block diagram.

The ssb generator (modulator) combines its audio input and its carrier input to produce the two sidebands. The two sidebands are then fed to a filter that selects the desired sideband and suppresses the other one. By eliminating the carrier and one of the sidebands, intelligence is transmitted at a savings in power and frequency bandwidth.

In most cases ssb generators operate at very low frequencies when compared with the normally transmitted frequencies. For that reason, we must convert (or translate) the filter output to the desired frequency. This is the purpose of the mixer stage. A second output is obtained from the frequency generator and fed to a frequency multiplier to obtain a higher carrier frequency for the mixer stage. The output from the mixer is fed to a linear power amplifier to build up the level of the signal for transmission.

Suppressed Carrier

In ssb the carrier is suppressed (or eliminated) at the transmitter, and the sideband frequencies produced by the carrier are reduced to a minimum. You will probably find this reduction (or elimination) is the most difficult aspect in the understanding of ssb. In a single-sideband suppressed carrier, no carrier is present in the transmitted signal. It is eliminated after modulation is accomplished and is reinserted at

the receiver during the demodulation process. All rf energy appearing at the transmitter output is concentrated in the sideband energy as "talk power."

After the carrier is eliminated, the upper and lower sidebands remain. If one of the two sidebands is filtered out before it reaches the power amplifier stage of the transmitter, the same intelligence can be transmitted on the remaining sideband. All power is then transmitted in one sideband, instead of being divided between the carrier and both sidebands, as it is in conventional AM. This provision gives you an increase in power for the wanted sideband. You should note in figure 2-8 that the bandwidth required for the ssb suppressed carrier, view B, is approximately half that needed for conventional AM, view A. This enables us to place more signals in a smaller portion of the frequency spectrum and permits a narrower receiver bandpass.

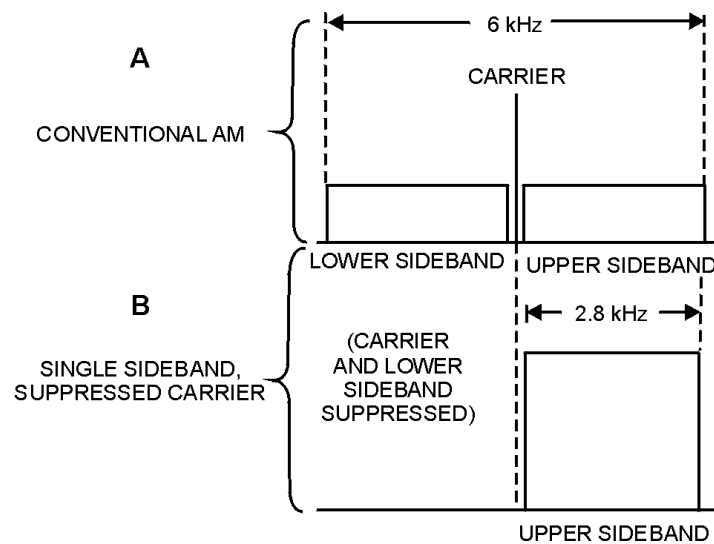

Figure 2-8.—Comparison of bandwidths of conventional AM and ssb voice channels.

Applications

Single-sideband transmission is the most common communications mode used today. Some of the ssb applications used in naval communications are described for you in the following paragraphs.

SSB VOICE CIRCUITS.—The high command (HICOM) network uses ssb as a means of communications between fleet commanders; and fleet commanders use it for communications between their subordinates and adjacent commands.

Ssb is generally used whenever special voice communications circuits are necessary between shore activities or between ships and shore activities because it is less susceptible to atmospheric interference than amplitude modulation.

SSB TELETYPEWRITER CIRCUITS.—With few exceptions, you will find ssb used on all long-haul (great distance) teletypewriter circuits, which includes ship-to-shore. Most of these systems are covered circuits; that is, an electronic cryptographic device on both ends of the circuit automatically encrypts and decrypts message traffic. These devices are used on point-to-point, ship-to-shore, ship-to-ship, and broadcast circuits.

Point-to-Point.—Most point-to-point, long-haul circuits between naval communications stations quickly use up the available frequency spectrum that ssb provides. Independent sideband (isb) transmission is normally used to compensate for the deficiency. Isb is used extensively in naval communications to expand our traffic capabilities. You will find there is a similarity between ssb and isb. Isb uses outputs from two sideband generators; it suppresses both carriers and then filters out an upper sideband from one and a lower sideband from the other. We then combine the two remaining sidebands and transmit an envelope with upper and lower sidebands that contain different intelligence. Isb can be used with MULTIPLEXING (a method for simultaneous transmission of two or more signals over a common carrier wave) to transmit a lot of intelligence on one circuit. Independent sideband and multiplexing will be discussed in more detail in chapter 3.

Ship-to-Shore.—Many ships handle enough message traffic to justify ship-to-shore teletypewriter circuits. Depending on traffic load, these circuits may contain from one to four (minimum) teletypewriter circuits on one sideband circuit. If the traffic load warrants more than one teletypewriter circuit, we usually use time division multiplex or frequency division multiplex (mux) equipment. This equipment is capable of handling many incoming and outgoing circuits. One circuit normally is used as an ORDERWIRE CIRCUIT for operator-to-operator service messages and for making frequency changes when necessary. The remaining circuits are available for handling official message traffic.

Q8. Why are frequency multipliers used?

Q9. What are two advantages of ssb transmission?

Q10. What is the purpose of an order-wire circuit?

Ship-to-Ship.—Ship-to-ship ssb teletypewriter circuits are in wide use today. Their main application is with task force or task group networks or with several ships in company. By using this type of network, ships can send their outgoing messages to another ship that relays traffic ashore. You can see this procedure saves manpower and circuit time, prevents individual ships from overcrowding ship-to-shore circuits, and conserves the frequency spectrum. Depending on the number and types of ships in company, the guard can be shifted to other ships from time to time. A major advantage of these circuits is that electronic cryptographic devices can be used to send classified messages without need for manual encryption. These circuits are used for incoming as well as outgoing traffic, and they can use either hf or uhf communications equipment.

RECEIVER FUNDAMENTALS

An AM receiver processes amplitude-modulated signals received by its antenna. It delivers an output that is a reproduction of the signal that originally modulated the rf carrier at the transmitter. The signal can then be applied to some reproducing device, such as a loudspeaker, or to a terminal device, such as a teletypewriter. Actual AM receivers vary widely in complexity. Some are very simple; others contain a large number of complex circuits.

FUNCTIONS

Whatever its degree of sophistication, a receiver must perform certain basic functions to be useful. These functions, in order of their performance, are *reception, selection, detection, and reproduction.*

Reception

Reception occurs when a transmitted electromagnetic wave passes through the receiver antenna and induces a voltage in the antenna.

Selection

Selection is the ability of the receiver to select a particular frequency of a station from all other station frequencies appearing at the antenna of the receiver.

Detection

Detection is the action of separating the low (audio) frequency intelligence from the high (radio) frequency carrier. A detector circuit is used to accomplish this action.

Reproduction

Reproduction is the action of converting the electrical signals to sound waves, which can then be interpreted by your ear as speech, music, and the like. An example of this might be the stereo speakers in your car.

RECEIVER CHARACTERISTICS

Sensitivity, noise, selectivity, and fidelity are important receiver characteristics. These characteristics will be useful to you when performing receiver tests. They can help you to determine whether a receiver is working or not or in comparing one receiver to another.

Sensitivity

The ability of a receiver to reproduce weak signals is a function of the sensitivity of a receiver. The weaker a signal that can be applied to a receiver and still produce a certain value of signal output, the better the sensitivity rating. Sensitivity of a receiver is measured under standardized conditions. It is expressed in terms of the signal voltage, usually in the microvolts that must be applied to the antenna input terminals to give an established level of the output. The output may be an ac or dc voltage measured at the detector output or a power measurement (measured in decibels or watts) at the loudspeaker or headphone terminals.

Noise

All receivers generate a certain amount of noise, which you must take into account when measuring sensitivity. Receiver noise may originate from the atmosphere (lightning) or from internal components (transistors, tubes). Noise is the limiting factor of sensitivity. You will find sensitivity is the value of input carrier voltage (in microvolts) that must be applied from the signal generator to the receiver input to develop a specified output power.

Selectivity

Selectivity is the degree of distinction made by the receiver between the desired signal and unwanted signals. You will find the better the ability of the receiver to reject unwanted signals, the better its selectivity. The degree of selection is determined by the sharpness of resonance to which the frequency-determining circuits have been engineered and tuned. You usually measure selectivity by taking a series of sensitivity readings. As you take the readings, you step the input signal along a band of frequencies above and below the circuit resonance of the receiver; for example, 100 kilohertz below to 100 kilohertz

above the tuned frequency. As you approach the tuned frequency, the input level required to maintain a given output level will fall. As you pass the tuned frequency, the required input level will rise. Input voltage levels are then compared with frequency. They can be plotted on paper or you might view them on an oscilloscope. They would appear in the form of a response curve. The steepness of the response curve at the tuned frequency indicates the selectivity of the receiver.

Fidelity

The fidelity of a receiver is its ability to accurately reproduce, in its output, the signal that appears at its input. You will usually find the broader the band passed by frequency selection circuits, the greater your fidelity. You may measure fidelity by modulating an input frequency with a series of audio frequencies; you then plot the output measurements at each step against the audio input frequencies. The resulting curve will show the limits of reproduction.

You should remember that good selectivity requires that a receiver pass a narrow frequency band. Good fidelity requires that the receiver pass a broader band to amplify the outermost frequencies of the sidebands. Receivers you find in general use are a compromise between good selectivity and high fidelity.

Q11. What four basic functions must a receiver perform?

Q12. What are the four basic receiver characteristics?

SUPERHETERODYNE RECEIVER

The superheterodyne is the type receiver most familiar to you. You probably see one daily in your home in the form of an AM and/or fm radio. We will discuss the basic workings of both AM and fm types and their differences.

Amplitude Modulation Receiver

Figure 2-9 shows a block diagram with waveforms of a typical AM superheterodyne receiver developed to overcome the disadvantages of earlier type receivers. Let's assume you are tuning the receiver. When doing this you are actually changing the frequency to which the rf amplifier is tuned. The rf carrier comes in from the antenna and is applied to the rf amplifier. The output of the amplifier is an amplified carrier and is sent to the mixer. The mixer also receives an input from the local oscillator. These two signals are beat together to obtain the IF through the process of heterodyning. (Heterodyning will be further discussed later in this chapter and was covered in NEETS, Module 12, *Modulation Principles*.) At this time you should note the dotted lines connecting the local oscillator, rf amplifier, and the mixer. This is used on block diagrams and schematics to indicate GANGED TUNING. Ganged tuning is the process used to tune two or more circuits with a single control. In our example, when you change the frequency of the receiver all three stages change by the same amount. There is a fixed difference in frequency between the local oscillator and the rf amplifier at all times. This difference in frequency is the IF. This fixed difference and ganged tuning ensures a constant IF over the frequency range of the receiver.

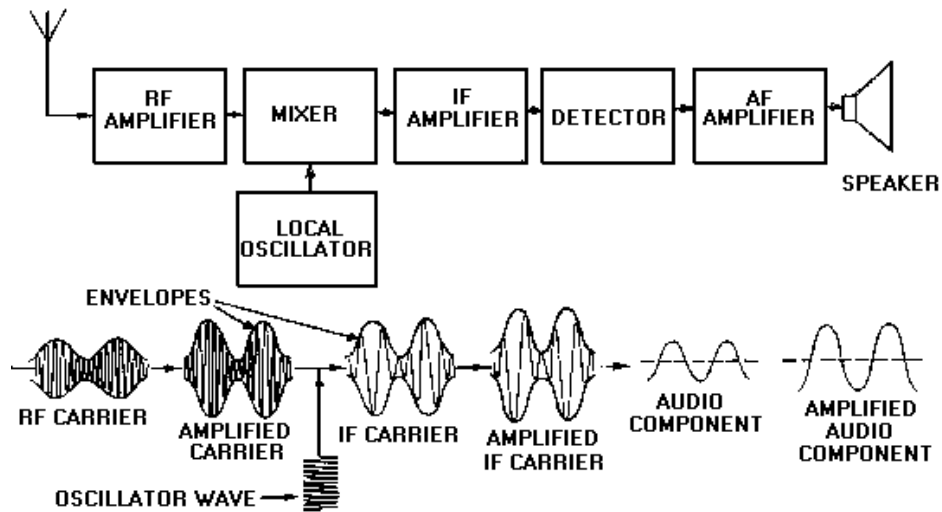

Figure 2-9.—AM superheterodyne receiver and waveforms.

The IF carrier is applied to the IF amplifier. The amplified IF carrier is then sent to the detector. The output of the detector is the audio component of the input signal. This audio component is then passed through an audio frequency amplifier. The amplified audio component is sent to a speaker for reproduction. This allows you to hear the signal.

You should note that a superheterodyne receiver may have more than one frequency-converting stage and as many amplifiers as needed to obtain the desired power output. (Additional amplifiers are not shown.)

HETERODYNING.—As you know the intermediate frequency is developed by a process called heterodyning. This action takes place in the mixer stage (sometimes called a converter or first detector). Heterodyning is the combining of the incoming signal with the local oscillator signal. When heterodyning the incoming signal and the local oscillator signal in the mixer stage, four frequencies are produced. They are the two basic input frequencies and the sum and the difference of those two frequencies. The amplifier that follows (IF amplifier) will be tuned to the difference frequency. This difference frequency is known as the intermediate frequency (IF). A typical value of IF for an AM communications receiver is 455 kilohertz. The difference frequency is a lower frequency than either the rf input or oscillator frequencies. This lower frequency gives slightly better gain but does increase the chances of image frequency interference. Image frequencies will be discussed later in this chapter.

DETECTION.—Once the IF stages have amplified the intermediate frequency to a sufficient level, it is fed to the detector. When the mixer is referred to as the first detector, this stage would be called the second detector. The detector extracts the modulating audio signal. The detector stage consists of a rectifying device and filter, which respond only to the amplitude variations of the IF signal. This develops an output voltage varying at an audio-frequency rate. The output from the detector is further amplified in the audio amplifier and is used to drive a speaker or earphones.

Frequency Modulated Receiver

The function of a frequency-modulated receiver is the same as that of an AM superheterodyne receiver. You will find some important differences in component construction and circuit design caused by differences in the modulating technique. Figure 2-10 is a block diagram showing waveforms of a typical fm superheterodyne receiver. Comparison of block diagrams in figures 2-9 and 2-10 shows that in both AM and fm receivers, the amplitude of the incoming signal is increased in the rf stages. The mixer

combines the incoming rf with the local oscillator signal to produce the intermediate frequency, which is then amplified by one or more IF amplifier stages. You should note that the fm receiver has a wide-band IF amplifier. The bandwidth for any type of modulation must be wide enough to receive and pass all the side-frequency components of the modulated signal without distortion. The IF amplifier in an fm receiver must have a broader bandpass than an AM receiver.

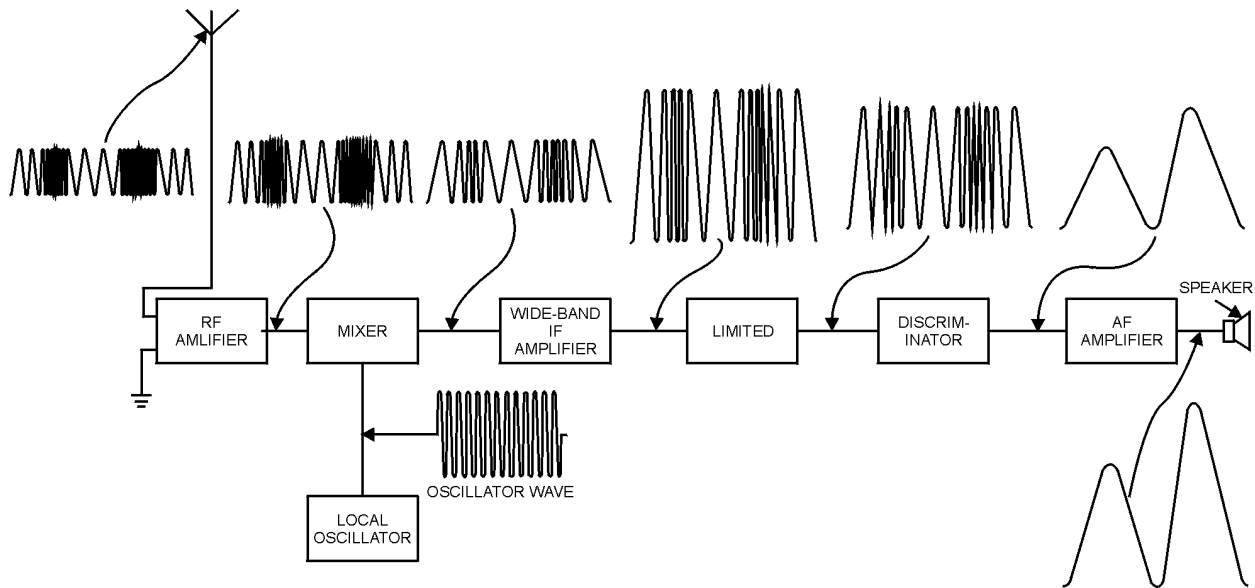

Figure 2-10.—Block diagram of an fm receiver and waveforms.

Sidebands created by fm differ from the AM system. You should recall that the AM system consists of a single set of side frequencies for each radio-frequency signal modulated. An fm signal inherently occupies a wider bandwidth than AM because the number of extra sidebands that occur in an fm transmission is directly related to the amplitude and frequency of the audio signal.

You should observe that only two fundamental sections of the fm receiver are electrically different from the AM receiver. These are the discriminator (detector) and the limiter.

Beyond the IF stage, the two receivers have a marked difference. AM demodulation involves the detection of variations in the amplitude of the signal; fm demodulation is the process of detecting variations in the frequency of the signal. In fm receivers a **DISCRIMINATOR** is a circuit designed to respond to frequency shift variations. A discriminator is preceded by a **LIMITER** circuit, which limits all signals to the same amplitude level to minimize noise interference. The audio frequency component is then extracted by the discriminator, amplified in the af amplifier, and used to drive the speaker.

ADVANTAGES.—In normal reception, fm signals are almost totally absent of static while AM signals are subject to cracking noises and whistles. Fm followed AM in development and has the advantage of operating at a higher frequency where a greater amount of frequencies are available. Fm signals provide much more realistic sound reproduction because of an increase in the number of sidebands. This increase in the number of sidebands allows more of the original audio signal to be transmitted and, therefore, a greater range of frequencies for you to hear.

As you can see, fm requires a wide bandpass to transmit signals. Each transmitting station must be assigned a wide band in the fm frequency spectrum. During fm transmissions, the number of significant

sidebands that must be transmitted to obtain the desired fidelity is related to the deviation (change in carrier' frequency) divided by the highest audio frequency to be used. At this point you may want to review chapter 2 of NEETS, Module 12, *Modulation Principles*. For example, if the deviation is 40 kilohertz and the highest audio frequency is 10 kilohertz, the modulation index is figured as shown below:

$$\frac{40 \text{ kilohertz}}{10 \text{ kilohertz}} = 4$$

In this example, a modulation index of 4 equates to 14 significant sidebands. Because the audio frequency is 10 kilohertz and there are 14 side-bands, the bandwidth must accommodate a 140-kilohertz signal. You can see this is considerably wider than the 10-to-15-kilohertz bandpass used in AM transmitting.

FREQUENCY CONVERSION.—Frequency conversion is accomplished by using the heterodyne principle of beating two frequencies together to get an intermediate frequency. So far, you have only become familiar with single conversion; however, some receivers use double or triple conversion. These methods are sometimes referred to as double or triple heterodyning. Receivers using double or triple conversion are very selective and suppress IMAGE SIGNALS to yield sharp signal discrimination. (Image signals are undesired, modulated carrier signals that differ by twice the intermediate frequency from the frequency to which the superheterodyne receiver is tuned.) Double and triple conversion receivers also have better adjacent channel selectivity than can be realized in single conversion sets.

In military communications receivers you may sacrifice fidelity to improve selectivity. This is permitted because intelligence (voice, teletypewriter) can be carried on a fairly narrow band of frequencies. Entertainment receivers, on the other hand, must reproduce a wider band of frequencies to achieve their high-fidelity objective.

Q13. What frequency conversion principle is used to develop the IF?

Q14. What is the function of the detector?

Q15. What is the major disadvantage of an fm signal as compared to an AM signal?

SINGLE-SIDEBAND

You know from studying the single-sideband transmitter material in this chapter you may transmit only one sideband of an AM signal and retain the information transmitted. Now you will see how a single-sideband signal is received.

Advantages

Figure 2-11 illustrates the transmitted signal for both AM and ssb. Ssb communications has several advantages. When you eliminate the carrier and one sideband, all of the transmitted power is concentrated in the other sideband. Also, an ssb signal occupies a smaller portion of the frequency spectrum in comparison to the AM signal. This gives us two advantages, narrower receiver bandpass and the ability to place more signals in a small portion of the frequency spectrum.

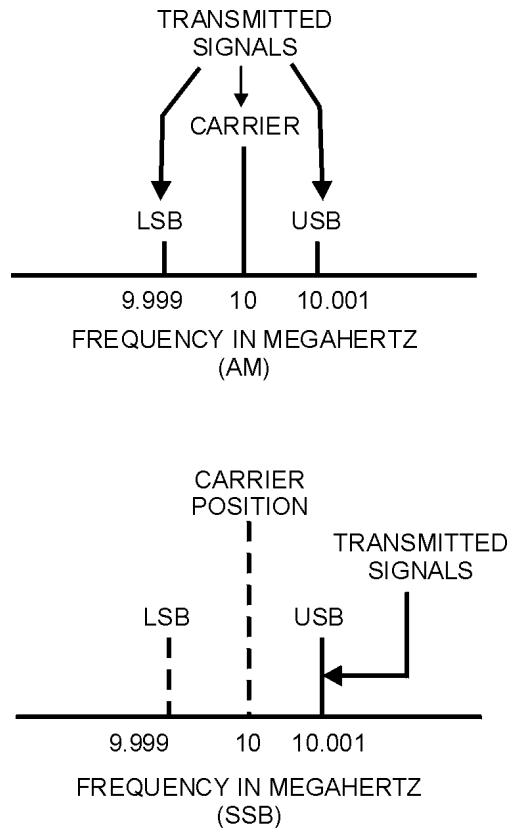

Figure 2-11.—Comparison of AM and ssb transmitted signals.

Ssb communications systems have some drawbacks. The process of producing an ssb signal is somewhat more complicated than simple amplitude modulation, and frequency stability is much more critical in ssb communication. While we don't have the annoyance of heterodyning from adjacent signals, a weak ssb signal is sometimes completely masked or hidden from the receiving station by a stronger signal. Also, a carrier of proper frequency and amplitude must be reinserted at the receiver because of the direct relationship between the carrier and sidebands.

Figure 2-12 is a block diagram of a basic ssb receiver. It is not significantly different from a conventional superheterodyne AM receiver. However, a special type of detector and a carrier reinsertion oscillator must be used. The carrier reinsertion oscillator must furnish a carrier to the detector circuit. The carrier must be at a frequency which corresponds almost exactly to the position of the carrier used in producing the original signal.

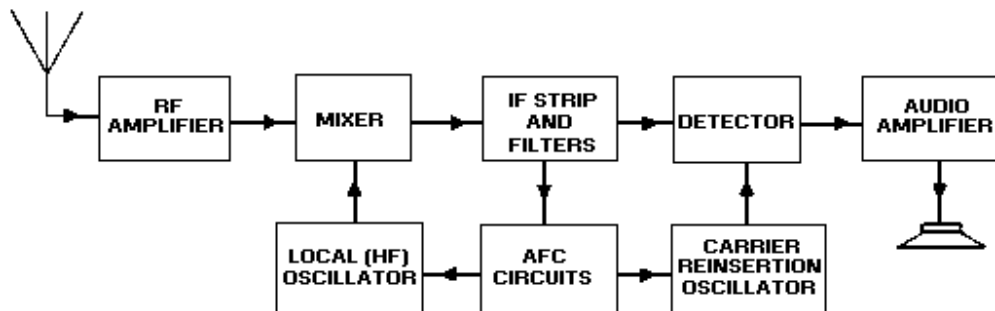

Figure 2-12.—Basic ssb receiver.

Rf amplifier sections of ssb receivers serve several purposes. Ssb signals may exist in a small portion of the frequency spectrum; therefore, filters are used to supply the selectivity necessary to adequately receive only one of them. These filters help you to reject noise and other interference.

Ssb receiver oscillators must be extremely stable. In some types of ssb data transmission, a frequency stability of ± 2 hertz is required. For simple voice communications, a deviation of ± 50 hertz may be tolerable.

These receivers often employ additional circuits that enhance frequency stability, improve image rejection, and provide automatic gain control (agc). However, the circuits contained in this block diagram are in all single-sideband receivers.

Carrier Reinsertion

The need for frequency stability in ssb operations is extremely critical. Even a small deviation from the correct value in local oscillator frequency will cause the IF produced by the mixer to be displaced from its correct value. In AM reception this is not too damaging, since the carrier and sidebands are all present and will all be displaced an equal amount. Therefore, the relative positions of carrier and sidebands will be retained. However, in ssb reception there is no carrier, and only one sideband is present in the incoming signal.

The carrier reinsertion oscillator frequency is set to the IF frequency that would have resulted had the carrier been present. For example, assume that a transmitter with a suppressed carrier frequency of 3 megahertz is radiating an upper sideband signal. Also assume that the intelligence consists of a 1-kilohertz tone. The transmitted sideband frequency will be 3,001 kilohertz. If the receiver has a 500-kilohertz IF, the correct local oscillator frequency is 3,500 kilohertz. The output of the mixer to the IF stages will be the difference frequency, 499 kilohertz. Therefore, the carrier reinsertion oscillator frequency will be 500 kilohertz, which will maintain the frequency relationship of the carrier to the sideband at 1 kilohertz.

Recall that 1 kilohertz is the modulating signal. If the local oscillator frequency should drift to 3,500.5 kilohertz, the IF output of the mixer will become 499.5 kilohertz. The carrier reinsertion oscillator, however, will still be operating at 500 kilohertz. This will result in an incorrect audio output of 500 hertz rather than the correct original 1-kilohertz tone. Suppose the intelligence transmitted was a complex signal, such as speech. You would then find the signal unintelligible because of the displacement of the side frequencies caused by the local oscillator deviation. The local oscillator and carrier reinsertion oscillator must be extremely stable.

Q16. What two components give a ssb receiver its advantages over an AM superheterodyne receiver?

RECEIVER CONTROL CIRCUITS

This section deals with circuits that control receiver functions. We will explain how some of the basic manual and automatic receiver control functions work.

Manual Gain Control (mgc)

You learned previously that high sensitivity is one of the desirable characteristics of a good receiver. In some cases high sensitivity may be undesirable. For example, let's suppose the signals received from a nearby station are strong enough to overload the rf sections of your receiver. This may cause the audio output to become distorted to the point of complete loss of intelligibility. To overcome this problem, you can use manual gain control of the rf section. By using the manual gain control, you can adjust the receiver for maximum sensitivity and amplify weak input signals. When you receive a strong input signal,

the rf gain may be reduced to prevent overloading. A typical manual gain control circuit for a receiver is illustrated in figure 2-13. Let's go through the basic circuitry.

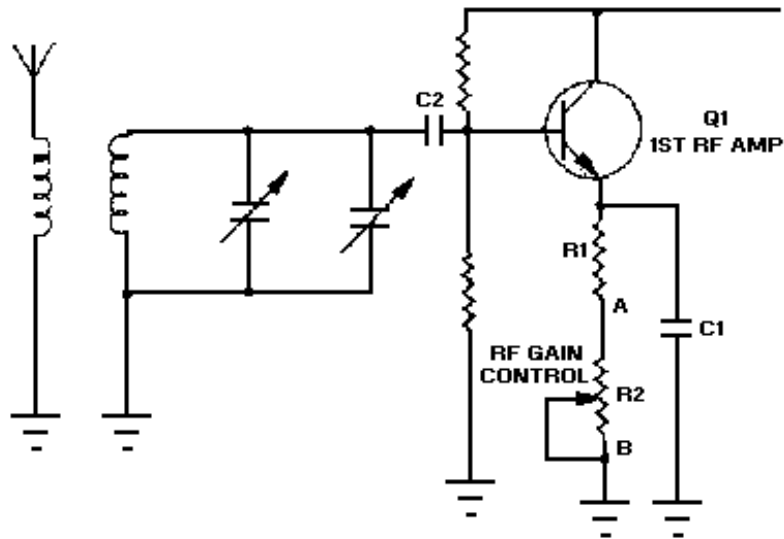

Figure 2-13.—Typical rf gain control.

C1 is an emitter bypass capacitor. Resistors R1 and R2 develop emitter bias for the amplifier. C2 provides dc isolation between the tank and the base of transistor Q1. You should recall from your studies of NEETS, Module 7, *Introduction to Solid-State Devices and Power Supplies*, and Module 8, *Introduction to Amplifiers*, that amplifier gain may be varied by changing bias. Potentiometer R2, the rf gain control, is nothing more than a manual bias adjustment. When the wiper arm of R2 is set at point B, minimum forward bias is applied to the transistor. This causes the amplifier to operate closer to cutoff and reduces gain. When you move the control toward point A, the opposite occurs. R1 limits the maximum conduction of Q1 when R2 is short circuited. You may run into an alternate biasing method when the transistor is operated near saturation. In that case, a large change in gain would again be a function of bias.

Manual Volume Control (mvc)

Figure 2-14 shows the circuitry for a common method of controlling volume in a superheterodyne receiver. C1 and R1 form an input signal coupling circuit and are also the means of controlling the level applied to the audio amplifier. R1, R2, and R3 develop forward bias and set the operating point for the transistor amplifier. R4 is the collector load resistor for Q1, and C3 is the output coupling capacitor. Potentiometer R1 in the circuit shown causes the input impedance of the stage to remain fairly constant. The signal from the preceding stage is felt across R1. By adjusting R1, you can change the input level to Q1 and vary the output amplitude.

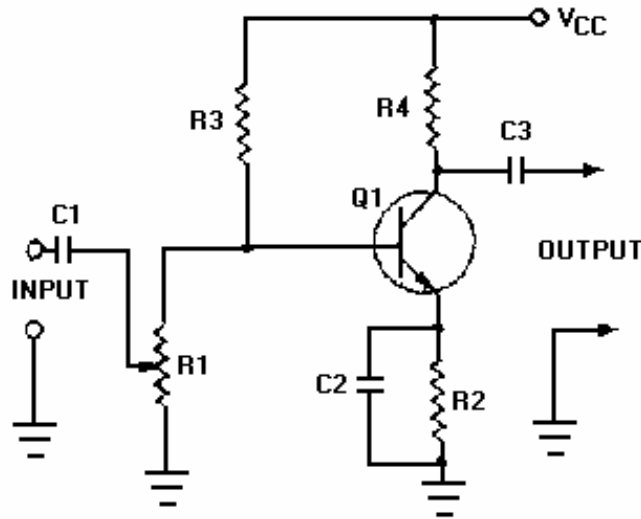

Figure 2-14.—Typical manual gain/volume control.

Automatic Gain/Volume Control (agc/avc)

Output volume variations of a receiver often result from variations in the input signal strength. Changes in input signal strength occur when we change stations or when we experience fading because of changing atmospheric conditions. The function of an AUTOMATIC GAIN CONTROL, also referred to as an AUTOMATIC VOLUME CONTROL, is to limit unwanted variations in the output of the receiver caused by variations in strength of the received signal input. A receiver without agc would require continuous manual readjustment to compensate for received signal changes so that it could maintain a constant output level.

Signals from stations operating at the same power level may not reach the receiver antenna with the same power. This is because of differences in transmission distances, carrier frequencies, atmospheric conditions, and obstructions between the transmitter and receiver antennas.

You might draw the conclusion that an agc network is not necessary when the receiver is operating on a single station. However, this is not true; atmospheric conditions may cause the signal strength to vary (fade in and out), or the antenna may receive components of the signal which have traveled along different paths. For example, one component may travel directly from the antenna, and another may have been reflected from a distant object. The two signals will sometimes be in phase and at other times be out of phase, thus tending to reinforce or cancel each other. The result is a variation in signal strength at the receiver antenna. This variation in signal strength is often referred to as FADING. The effect of fading in the output signal voltage of an rf stage is best demonstrated by the following example: An rf amplifier connected to a receiving antenna has a voltage gain of 100. If the antenna receives an input signal of 10 microvolts, the output voltage is computed as follows:

$$100 \times 10 \text{ microvolts} = 1,000 \text{ microvolts}$$

or

$$1 \text{ millivolt.}$$

With the output voltage equal to 1 millivolt, and if fading is to be avoided, the output voltage must remain at 1 millivolt. However, if a reflected signal is received that is approximately one-half the strength (5 microvolts) of the original and is in phase with the original signal, the total input signal to the receiving

antenna will increase to 15 microvolts. To maintain the desired 1 millivolt of output signal, you must somehow reduce the gain of the rf amplifier. With an input of 15 microvolts and a desired output of 1 millivolt (1,000 microvolts), the gain of the amplifier must be reduced to:

$$\frac{1,000 \times 10^{-6} \text{ volts}}{15 \times 10^{-6} \text{ volts}} = 66.7$$

When the 10-microvolt original signal and the 5-microvolt reflected signal are out of phase with each other, the signal strength at the receiving antenna will decrease to 5 microvolts. If we want to maintain our original 1,000-microvolt output signal, the voltage gain of the amplifier must be increased as follows:

$$\frac{1,000 \times 10^{-6} \text{ volts}}{5 \times 10^{-6} \text{ volts}} = 200$$

A variation of amplifier gain, similar to the example, is necessary if we are going to compensate for input signal strength variations. The required amplifier gain variations can be accomplished automatically by the addition of an agc circuit within the receiver. Let's take a look at the methods and circuits used to produce agc and the manner in which agc (avc) controls receiver gain.

CIRCUITRY.—Figure 2-15 is a block diagram representing agc feedback to preceding stages. The detector circuit has a dc component in the output that is directly proportional to the average amplitude of the modulated carrier. The agc circuitry uses this dc component by filtering the detector output to remove the audio and IF components and by applying a portion of the dc component to the preceding stages. This agc voltage controls the amplification of any or all of the stages preceding the detector stage. Solid-state receivers may use either positive or negative voltage for agc. The type of transistors used and the elements to which the control voltage is applied determine which type we will have.

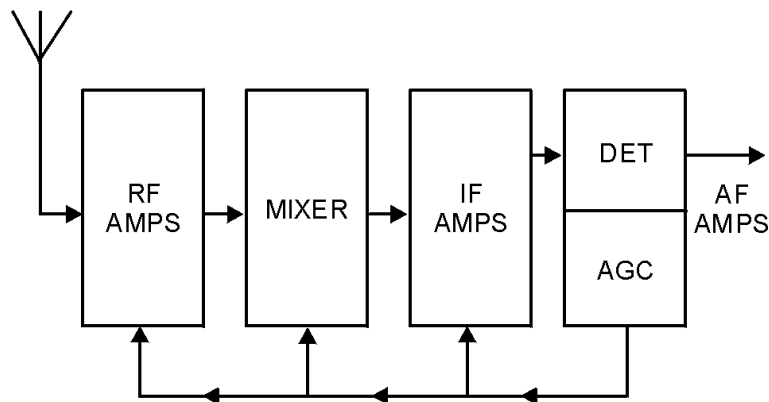

Figure 2-15.—Block diagram showing agc application.

The circuit shown in figure 2-16 produces a positive agc voltage. Transformer T1, diode CR1, capacitor C1, and resistor R1 comprise a series diode detector. The agc network is made up of R2 and C2. With normal detector operation and the positive (+) potential shown at the input, CR1 conducts. Conduction of the diode will cause a charging current (shown by the dashed line) to flow through agc capacitor C2 and agc resistor R2. This charging current develops a voltage across C2. When the potential across T1 reverses, the diode will be reverse biased and will not conduct. When this happens, the charging current ceases and C2 begins to discharge. The discharge path for C2 is shown by the solid arrows. The

discharge path time constant of C2, R1, and R2 is chosen to be longer than the period (1/f) of the lowest audio frequency present in the output of the detector. Because of the longer time constant, C2 will not discharge much between peaks of the modulating signal, and the voltage across C2 will be essentially a dc voltage. This voltage is proportional to the average signal amplitude. Now, if the signal strength varies, C2 will either increase or decrease its charge, depending on whether the signal increases or decreases. Since the charge on the agc capacitor responds only to changes in the average signal level, instantaneous variations in the signal will not affect the agc voltage.

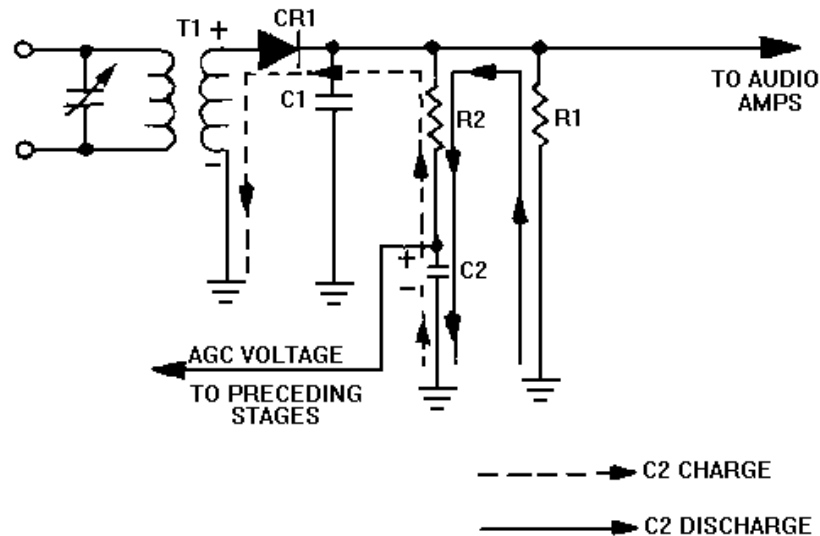

Figure 2-16.—Series diode detector and simple agc circuit.

You should remember that, depending on transistor types, the receiver may require either a positive or a negative agc voltage. A negative agc voltage could be easily obtained by reversing CR1. Once the values for R2 and C2 have been selected, the voltage divider action of the components is fixed, and the circuit operates automatically without further adjustment. If the average amplitude of the signal increases, the charge on C2 will also increase. If the signal amplitude decreases so does the charge on C2.

The agc voltages in a receiver provide controlled degenerative feedback. By adjusting the operating point of an amplifier, you can control the gain. Under no-signal conditions, bias of the rf and IF amplifiers is developed by standard means, such as self bias. With an applied signal, an agc voltage is developed, which in conjunction with normal biasing methods develops the operating bias for the amplifiers.

TRANSISTOR AMPLIFIER GAIN.—You have seen how a dc voltage that is obtained at the output of the agc network is proportional to, and will reflect, the average variations of the average signal level. Now all we have to do is use this agc voltage to control the amplification of one or more of the preceding amplifiers. Figure 2-17 illustrates a common-emitter amplifier with agc applied to the base element. A change in the agc voltage will change the operating point of the transistor and the dc emitter current. In this circuit, R1 and R4 form a voltage divider and establish no-signal (forward) bias on the base. Since a pnp transistor is used, the base has a negative potential. The agc voltage from the detector is positive with respect to ground and is fed to the base through dropping resistor R2. You will find when the dc output of the detector increases (because of an increase in the average signal level) the agc voltage will become more positive. This increased positive potential is applied to the base of Q1, which decreases the forward bias of Q1 and decreases the gain of the amplifier. Agc, in this application, works with

controlled degenerative feedback. Use of an npn transistor, in the same configuration, would require the agc voltage to possess a negative potential.

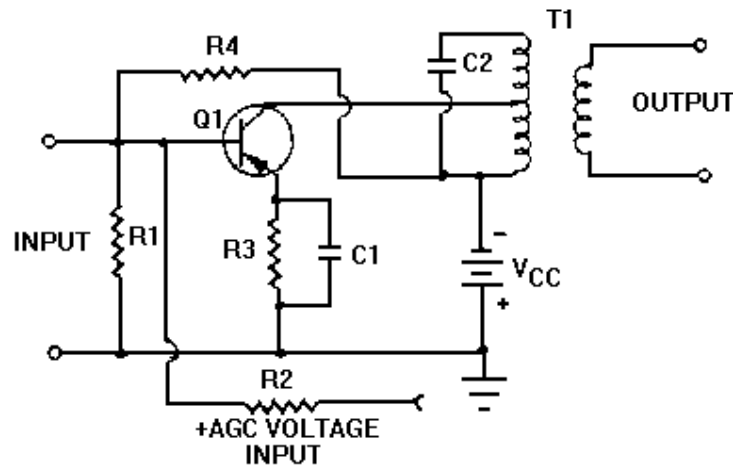

Figure 2-17.—Common emitter amplifier with agc.

FORWARD AND REVERSE AGC.—When we use an agc voltage to cause degeneration by driving the amplifiers toward cutoff, it is referred to as REVERSE agc. Figure 2-18 shows the type of agc circuitry normally used with this method. A second method that uses agc is an application called FORWARD agc. In the case of forward agc, you'll find the amplifier is driven toward the saturation region of its characteristic curve. (Sometimes referred to as an energy diagram.)

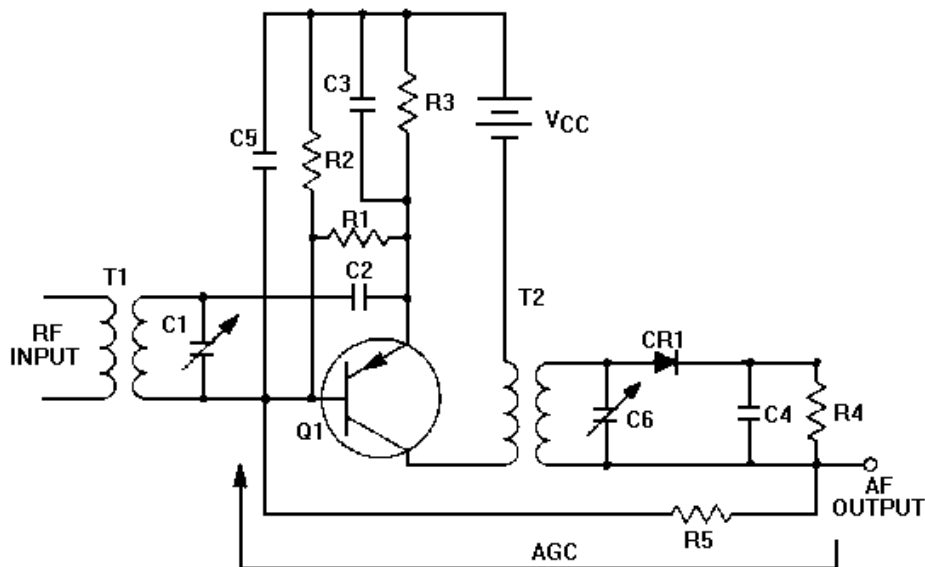

Figure 2-18.—Reverse agc.

Let's look at our example. Assume the agc voltage is negative. Under this condition, Q1 is self biased; under no-signal conditions, it is operating well up on its characteristic curve. When a signal is applied, negative agc voltage is developed in the detector circuit and fed back to Q1, which increases

forward bias. Any increase in signal level causes an increase in agc voltage. An increase in agc voltage increases conduction, which in turn drives the transistor to or near saturation. As the transistor approaches saturation, its gain is correspondingly reduced.

On the other hand, if the input signal level decreases, the negative agc voltage decreases. The forward bias is then reduced, and the transistor operates on a lower portion of its characteristic curve where gain is higher.

Forward agc provides you with better signal-handling capabilities; however, reverse agc is simpler to use, causes less loading of the tuned circuits, and produces smaller variations in input and output capacitance.

Q17. What does manual gain control do to strong and weak signals, respectively?

Q18. What is the purpose of agc/avc in a receiver?

Delayed Automatic Gain Control

The disadvantage of automatic gain control, attenuating even the weak signal, is overcome by the use of delayed automatic gain control (dadc). Let's take a look at the typical dadc circuitry in figure 2-19. This type of system develops no agc feedback until an established received signal strength is attained. For signals weaker than this value, no agc is developed. For sufficiently strong signals, the delayed agc circuit operates essentially the same as ordinary agc.

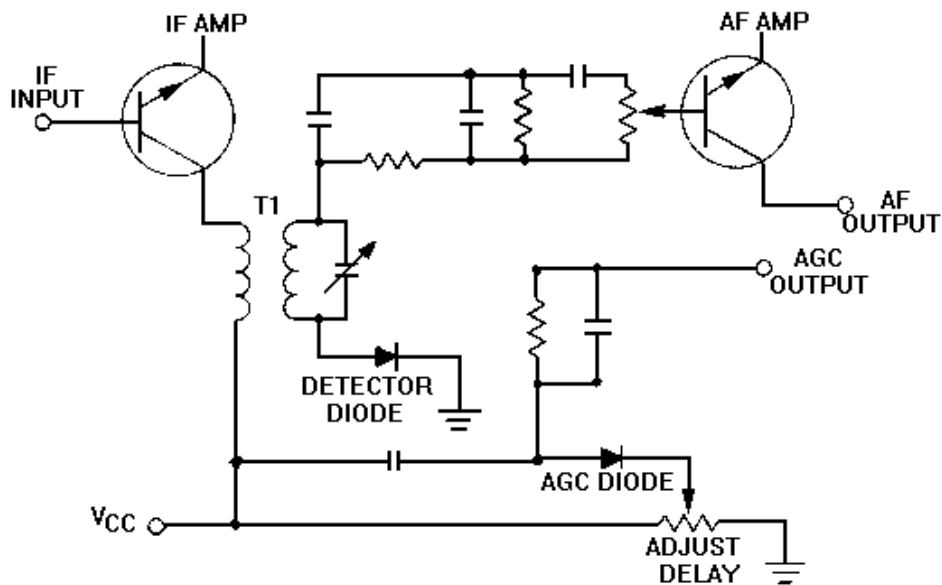

Figure 2-19.—Delayed agc action.

Our circuit uses two separate diodes; one is the detector diode and the other the agc diode. The agc diode is connected to the primary of the last IF transformer and the detector diode to its secondary. A positive bias is applied to the cathode of the agc diode. This keeps it from conducting until a prearranged signal level has been reached. The adjust delay control allows manual control of the agc diode bias. Manual control allows you to select the signal level at which agc is applied. If mostly weak stations are to

be received, the setting should be high (no agc until the signal level is high). However, you should set it as low as possible to prevent overloading of the last IF amplifier by stronger signals.

Finally, you must have two diodes to obtain delayed agc. If only one diode were used, the agc would be developed from the detector diode, and there would be no delayed action. Or, if a signal diode were biased to provide the delaying action desired, no signal would pass to the audio amplifier until the bias was exceeded by the input signal.

Beat-Frequency Oscillator

The beat-frequency oscillator (bfo) is necessary when you want to receive cw signals. Cw signals are not modulated with an audio component, you remember, so we must provide one. The action of the rf amplifier, mixer, local oscillator, and IF amplifier is the same for both cw and AM; but the cw signal reaches the detector as a single frequency signal with no sideband components. To produce an af output, you must heterodyne (beat) any cw signal with an rf signal of the proper frequency. This separate signal is obtained from an oscillator known as a beat-frequency oscillator.

Figure 2-20 is a block diagram of a superheterodyne receiver capable of receiving and demodulating a cw signal. The bfo heterodynes at the detector and produces an af output. The detector (second detector) is used primarily because the mixer (first detector) is normally used as the source of agc.

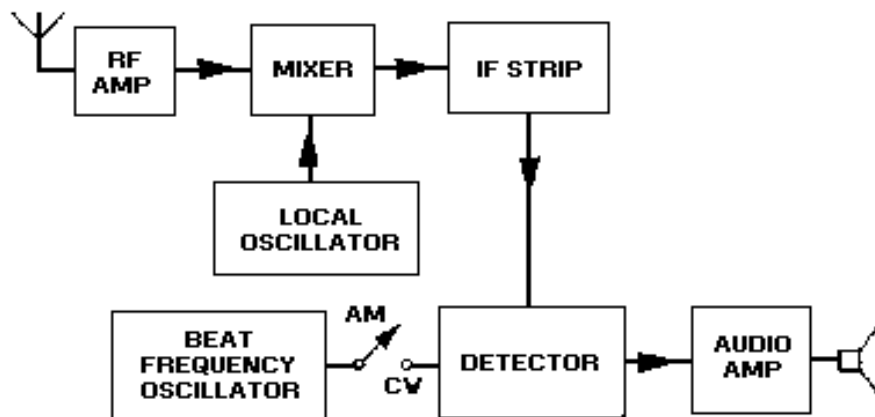

Figure 2-20.—Placement of the beat frequency oscillator.

If the intermediate frequency is 455 kilohertz and the bfo is tuned to 456 kilohertz or 454 kilohertz, the difference frequency of 1 kilohertz is heard in the output. Generally, you will tune the bfo from the front panel of a receiver. When you vary the bfo control, you are varying the output frequency of the bfo and will hear changes in the tone of the output audio signal.

Squelch

The sensitivity of a receiver is maximum when no signal is being received. This condition occurs, for example, when a receiver is being tuned between stations. At this time background noise is picked up by the antenna, and you will hear noise greatly amplified. This noise is highly annoying and occurs because receiver gain is maximum without a signal. You can often overcome this problem by using a circuit called a SQUELCH, NOISE SILENCER, NOISE SUPPRESSOR, or NOISE LIMITER. All of these noise type circuits just clip the peaks of the noise spikes. *Squelch* will actually eliminate noise. Figure 2-21 is a

typical circuit of this type. The circuit cuts off receiver output when no input signal is being received. It accomplishes this by blocking either the detector or audio amplifier when no signal is present. Let's take a look at the theory involved in this process.

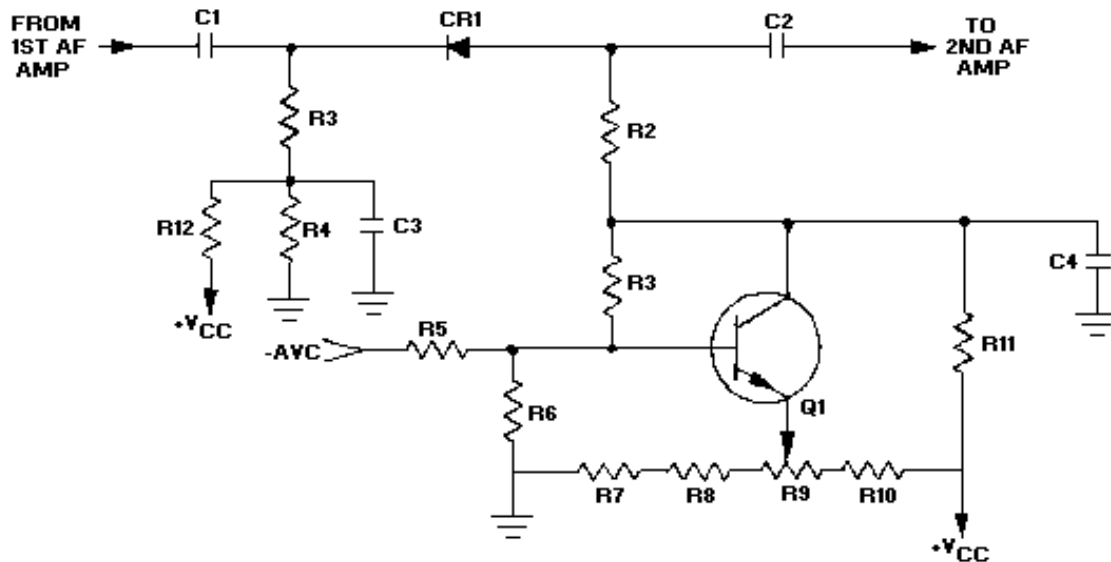

Figure 2-21.—Squelch circuit.

The squelch diode CR1 connects the output of the first af stage to the input of the second. Amplifier Q1 serves as the control transistor for the circuit. The anode and cathode voltages of CR1 are normally biased positive with respect to ground.

With no input signal, R9 is adjusted until Q1 draws enough collector current to reduce its collector voltage and the anode voltage of CR1 to a value below the voltage on the cathode of CR1. At this point the anode voltage of the squelch diode is negative with respect to its cathode, and conduction ceases. Audio output is now reduced to zero and the receiver is silent.

The base of Q1 is connected to the automatic volume control (avc) line. Anytime a signal enters the receiver, a negative avc voltage is applied to the base of Q1. This reduces the collector current and increases the collector voltage, which in turn increases the anode voltage of CR1 until the anode becomes positive with respect to the cathode. Once again diode CR1 will conduct, and the signal will be passed to the second af amplifier. Diode CR1 is effectively a switch controlled by the avc voltage.

Q19. What is a disadvantage of agc?

Q20. What is the main difference between agc and dagc?

Q21. What is the function of the bfo?

Q22. What is the purpose of a squelch circuit?

Audio Tone

The tone of the sound reproduced in the audio section of a receiver depends on several factors. The frequency response of the audio amplifiers determines the degree of amplification provided to different frequencies in the sound spectrum. The size and quality of any loudspeaker used will determine its response to various frequencies. Response of the human ear is the final judge of tonal quality, and that varies with the individual.

Because of these variables, some form of tone control is sometimes used in Navy receivers. Treble tones are defined as the audio frequencies above approximately 3,000 hertz and bass tones are those below approximately 300 hertz. Although several methods of tone control can be used, we are only going to mention the attenuation method. With this method, a decrease in the intensity of one tone can produce an apparent increase in the intensity of another tone. As an example, let's look at tones of 400 and 4,000 hertz produced by a speaker with the same intensity. If we reduce the intensity of the 4,000-hertz tone, the 400-hertz tone will appear to be louder, even though its intensity has not actually changed. You should see from this example that bass emphasis can be accomplished by attenuating treble tones.

The simplest type of tone control is illustrated in figure 2-22. Fixed capacitor C_1 parallels the primary winding of the output transformer, effectively shunting the higher frequencies to ground. The size of C_1 determines the lowest frequency to be affected. When you select the BASS position of the tone control, C_1 is connected and improves bass response by de-emphasizing the treble tones. You can often use this circuit to improve the output of a small speaker with poor treble response.

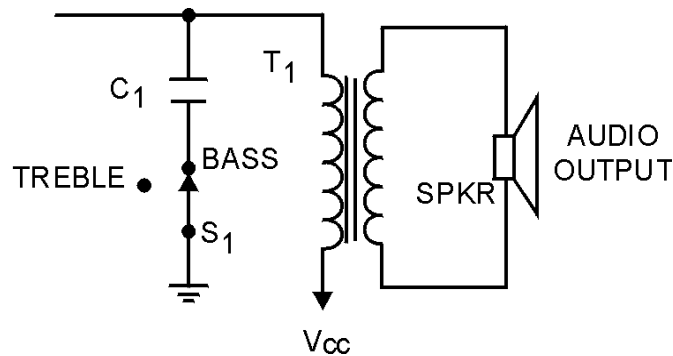

Figure 2-22.—Fixed capacitor tone control.

A continuously variable tone control is illustrated in figure 2-23. Tone control R_1 and bypass capacitor C_1 act as a variable RC filter. With the wiper arm of R_1 in the upper (BASS) position, C_1 bypasses the higher frequencies to ground and provides better bass response. When the wiper arm of R_1 is in the lower (TREBLE) position, the resistance of R_1 is placed in series with C_1 , which reduces the shunting effect of C_1 to high frequencies and improves the treble response. This method gives you the advantage of smooth, continuous tone control at all points between maximum bass and maximum treble response.

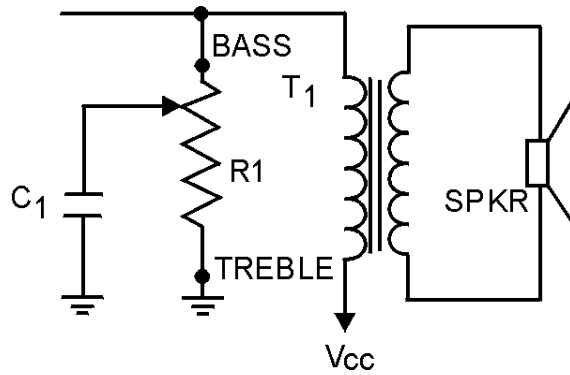

Figure 2-23.—Variable tone control using an RC filter.

A switch-type, variable tone control is illustrated in figure 2-24. With this method we use a three-position switch to provide fixed degrees of tone control. When tone control S1 is in the BASS position, capacitor C1 bypasses the high frequencies and provides bass emphasis. With S1 in the normal (NORM) position, C2 acts as the bypass, and a moderate amount of high-frequency attenuation is accomplished. This position provides balanced bass and treble response. When S1 is in the TREBLE position, C3 acts as the bypass and provides minimum high-frequency attenuation and maximum treble emphasis. As a rule of thumb, you can figure the capacitance of C2 is approximately five times the value of C3, and C1 is approximately ten times the value of C3. For example with C3 at .001 microfarads, C2 would be .005 microfarads, and C1 would be .01 microfarads.

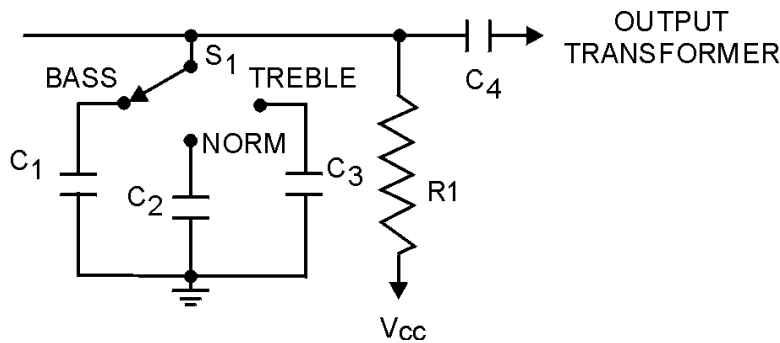

Figure 2-24.—Switch tone control.

Crystal Filters

A quartz crystal, used as a selective filter in the IF section of a communications receiver, is one of the most effective methods of achieving maximum selectivity. It is especially useful when the channel is crowded and considerable noise (both external and internal) is present.

One possible circuit arrangement is shown in figure 2-25. Let's look at the theory involved in understanding this circuit. You can see a crystal in one leg of the bridge circuit. The secondary of the input transformer (T1) is balanced to ground through the center tap connection. The crystal acts as a high Q series resonant circuit. It allows signals within the immediate vicinity of resonance to pass through the crystal to the output coil (L3). The desired signal appears between the center tap of L3 and ground.

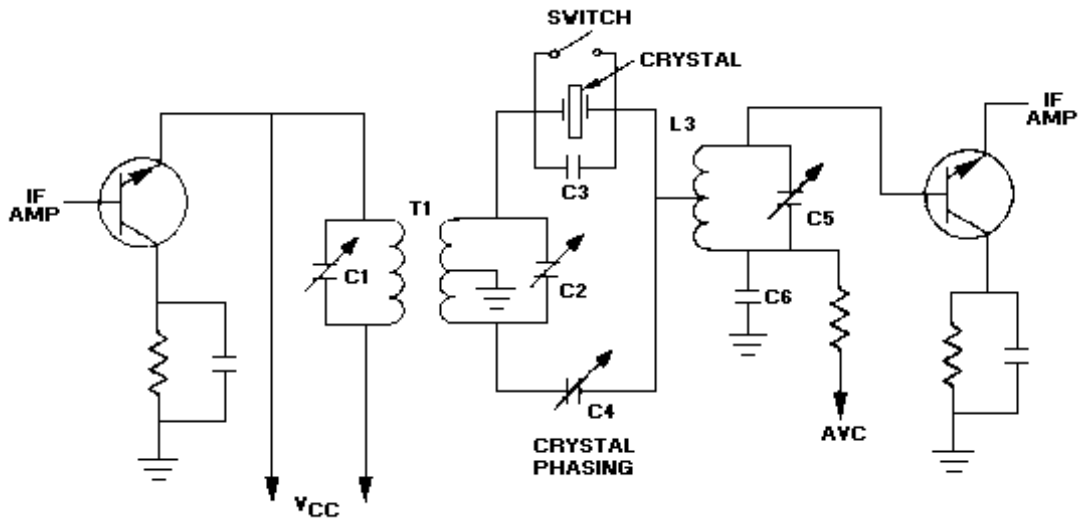

Figure 2-25.—Crystal filter used in the IF section of a superheterodyne receiver.

The capacitance that exists between the crystal holder plates (C3) may bypass unwanted signals around the crystal; therefore, some method must be provided to balance out this capacitance. You accomplish circuit balancing by applying out-of-phase voltages to neutralize any undesired signal voltages. The tap on L3 permits proper impedance matching and is the balanced input to the next stage.

Q23. What does a tone control circuit in a receiver do to the audio signal?

Q24. What is the function of a crystal filter in a receiver?

Automatic Frequency Control

Afc circuits are used in situations where you must accurately control the frequency of an oscillator by some external signal. Basically, this type circuit does two things: It senses the difference between the actual oscillator frequency and the frequency that is desired and produces a control voltage proportional to the difference; it also uses the control voltage to change the oscillator to the desired frequency. Afc circuits are used to control the frequency of sinusoidal oscillators and nonsinusoidal oscillators. Only sinusoidal afc circuits will be covered here. Afc circuits are used in radio receivers, fm transmitters, and frequency synthesizers to maintain frequency stability. Figure 2-26 is a block diagram illustrating afc operation in a receiver. Let's run through the applicable parts of this block diagram.

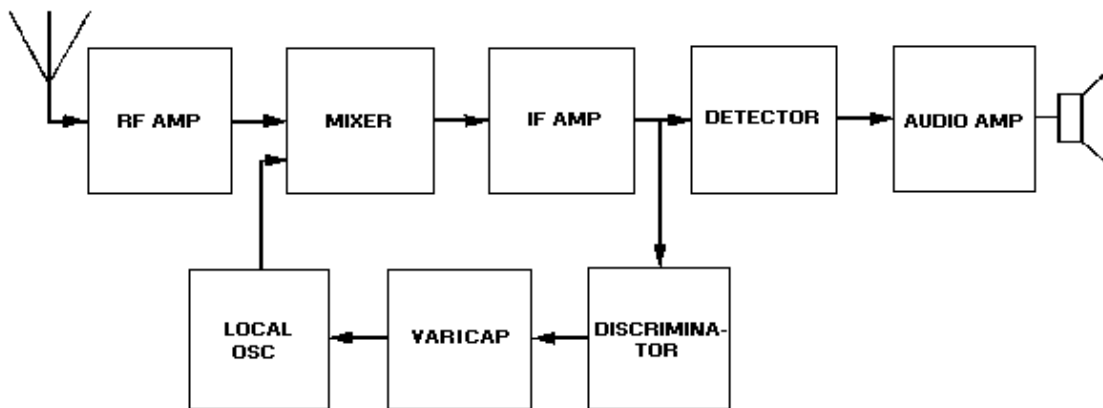

Figure 2-26.—Block diagram of receiver showing automatic frequency control.

The frequency discriminator controls the varicap in this receiver. A varicap is used to keep the IF stable. You may want to review varicap theory in chapter 3 of NEETS, Module 7, *Introduction to Solid-State Devices and Power Supplies* at this point. The varicap application here produces an apparent reactance, which is included in the oscillator frequency control circuitry. For example, let's assume the IF is 455 kilohertz and the local oscillator (lo) is tracking below the incoming station. When the lo output decreases slightly in frequency, the IF will rise. This causes the output of the discriminator to increase the capacitive reactance of the varicap, which increases the oscillator frequency to the desired value. Now let's assume the lo output increases. The IF will then decrease. This causes the discriminator output to decrease the capacitive reactance of the varicap. This will cause the oscillator frequency to decrease.

Figure 2-27 shows another widely used type of afc and its circuitry. This type is commonly referred to as a BALANCED-PHASE DETECTOR or PHASE-DISCRIMINATOR. This circuit uses fixed capacitors and the varying conductance of the diodes to achieve a variable reactance. As you have seen in the block diagram, an afc circuit requires two sections, a frequency detector and a variable reactance. Our detector output is a dc control voltage proportional to the amount of frequency change. This dc voltage is applied directly to the oscillator. The phase inverter input signals are discriminated IF outputs fed to the two diodes 180 degrees out of phase.

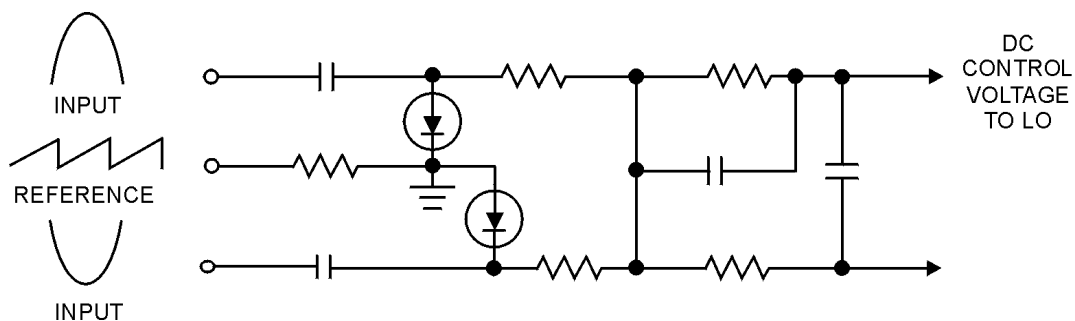

Figure 2-27.—Automatic frequency control (phase discriminator).

A reference voltage is also applied to both diodes. The diodes are biased to conduct only during the peak portions of the input signals. Any change in oscillator frequency will alter the phase relationship between the sawtooth reference voltage and the incoming signals. If this happens, one diode will conduct

more than the other and produce a control signal. This system remains unbalanced at all times because any change in frequency is instantaneously corrected. The network between the diodes and oscillator is essentially a low-pass filter. This filter prevents discriminator pulses from reaching the oscillator.

FREQUENCY SYNTHESIS

In present day communications systems, long term accuracy of one part in a million is required from many of the frequency generators (local oscillators) used in communications equipment. Variable frequency oscillators cannot practically achieve this high degree of stability. Therefore, a system known as FREQUENCY SYNTHESIS has been developed to meet the stringent demands for stability. This system uses circuitry that produces a signal frequency through a heterodyning and frequency selection process. This signal is not harmonically related to any of the signals used in the heterodyning process. It is also not related to the selected crystal frequency. This makes the signal unique.

Figure 2-28 is a multiple crystal, frequency synthesizer that produces desired output frequencies by mixing frequencies from several crystal oscillators. Each oscillator uses ten or more crystals to control its operating frequency. This provides for a large number of output frequency combinations. Figure 2-29 is a practical frequency synthesizer in which the harmonics and subharmonics of a single standard oscillator are combined to provide a wide multichoice of output signals. Each of these signals is harmonically related to a subharmonic of the standard oscillator. You will find the primary difficulty encountered in the frequency synthesizers is the presence of spurious signals generated in the "combining mixers." Extensive filtering and extremely careful selection of operating frequencies are required for even the simplest circuits. Spurious frequency problems increase and channel spacing decreases as the range of operating frequencies increases.

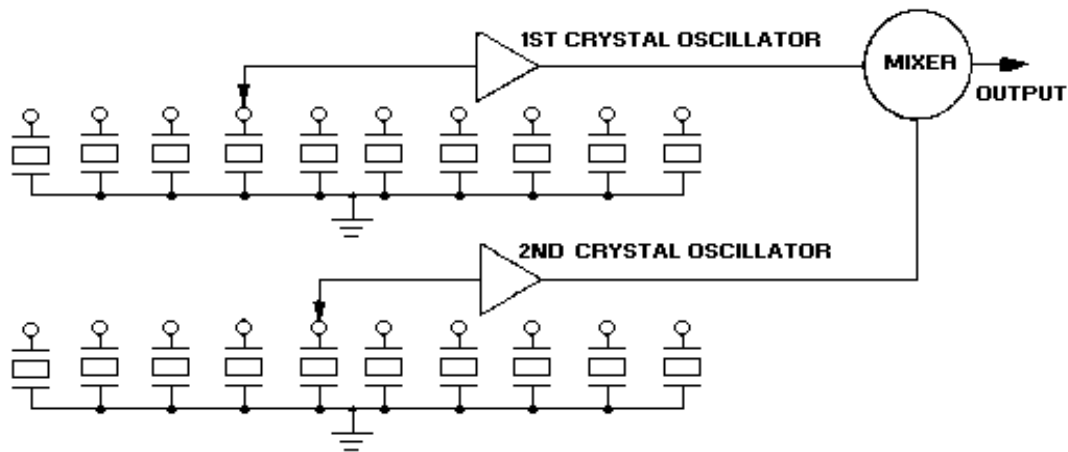

Figure 2-28.—Multiple crystal frequency synthesizer.

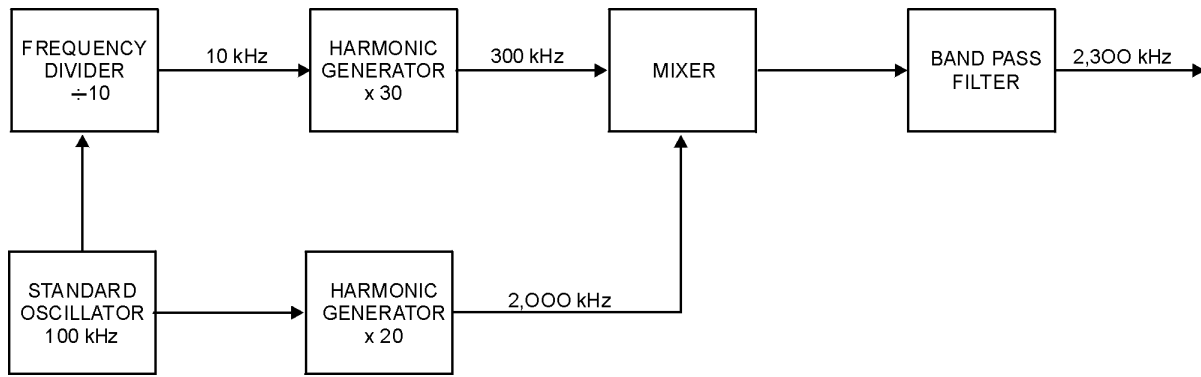

Figure 2-29.—Simple crystal frequency synthesizer.

Q25. What is the primary function of an afc circuit?

Q26. What is frequency synthesis?

AUDIO REPRODUCTION DEVICES

The purpose of audio reproduction devices, such as loudspeakers and headphones, is to convert electrical audio signals to sound power. Figure 2-30 shows you a diagram of a loudspeaker called the PERMANENT MAGNET SPEAKER. This speaker consists of a permanent magnet mounted on soft iron pole pieces, a voice coil that acts as an electromagnet, and a loudspeaker cone connected to the voice coil. The audio signal has been previously amplified (in terms of both voltage and power) and is applied to the voice coil. The voice coil is mounted on the center portion of the soft iron pole pieces in an air gap so that it is mechanically free to move. It is also connected to the loudspeaker cone; as it moves, the cone will also move. When audio currents flow through the voice coil, the coil moves back and forth proportionally to the applied ac current. As the cone (diaphragm) is attached to the voice coil, it also moves in accordance with the signal currents; in so doing, it periodically compresses and rarefies the air, which produces sound waves.

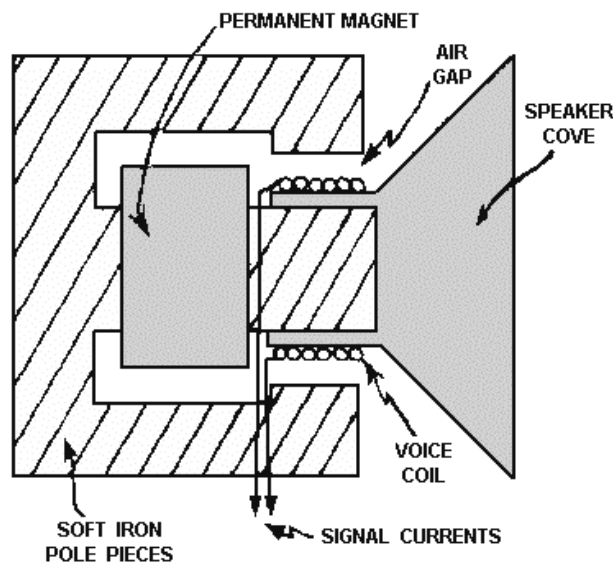

Figure 2-30.—Permanent magnet speaker.

Most speakers of the above type receive their input by means of transformer coupling. This is necessary because of the normal, low impedance of the voice coil. You will find the standard impedance values for this type speaker are 4, 8, 16, and 32 ohms. Other impedance values may be obtained, but those listed are the most common.

While permanent magnet speakers perform reasonably well in the audio range, they have limitations. Most Navy speakers reproduce low audio frequencies quite well, mid-band frequencies fairly well, and high frequencies quite poorly. Let's see why. When the speaker is constructed, only a limited number of turns may be built into the voice coil. This gives us a fixed inductance. At low frequencies, the inductive reactance of the voice coil is relatively low, and large audio currents flow. This provides a strong magnetic field around the voice coil and a strong interaction with the field of the permanent magnet. Low frequency response is excellent. At midband frequencies, inductive reactance increases and less current flows in the voice coil. This produces less magnetic field and less interaction. Midband response is still acceptable in a properly designed speaker. At high audio frequencies inductive reactance is quite high, and little current flows in the voice coil. This results in a greatly reduced voice coil field and little interaction with the permanent magnetic field. Also at high frequencies the interwinding capacitance of the voice coil tends to shunt some of the high audio frequencies, which further reduces the high frequency response.

Frequency response of most permanent magnet speakers falls off at the higher audio frequencies. This problem is normally overcome either by the use of an expensive, specially designed speaker, or through the use of two speakers, one of which is designed to operate well at the higher audio frequencies (tweeter) and one at the lower frequencies (woofer).

As shown in figure 2-31, an electromagnet may be used in place of a permanent magnet to form an electromagnetic dynamic speaker. When we do this, sufficient dc power must be available to energize the field electromagnet. The operation otherwise is much the same as that of the permanent magnet type. This type of speaker is seldom used in Navy equipment.

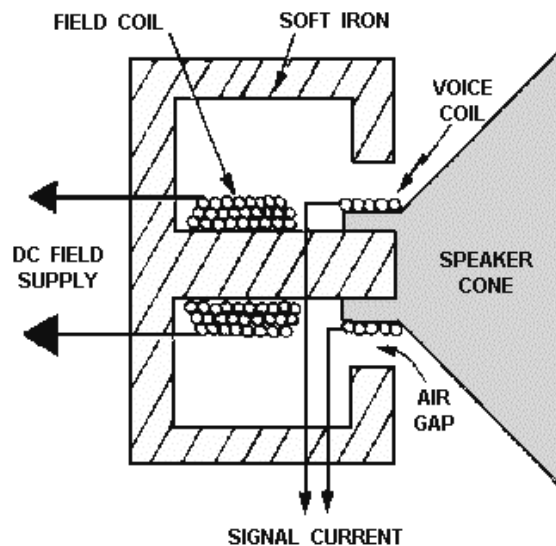

Figure 2-31.—Electromagnetic speaker.

Figure 2-32 shows a diagram of typical headphones used with Navy equipment. The device consists of a permanent magnet and two small electromagnets through which the signal currents pass. A soft iron diaphragm is used to convert the electrical effects of the device into sound power. When no signal currents are present, the permanent magnet exerts a steady pull on the soft iron diaphragm. Signal current flowing through the coils mounted on the soft iron pole pieces develops a magnetomotive force that either adds to or subtracts from the field of the permanent magnet. The diaphragm thus moves in or out according to the resultant field. Sound waves are then reproduced that have an amplitude and frequency (within the mechanical capability of the reproducer) similar to the amplitude and frequency of the signal currents.

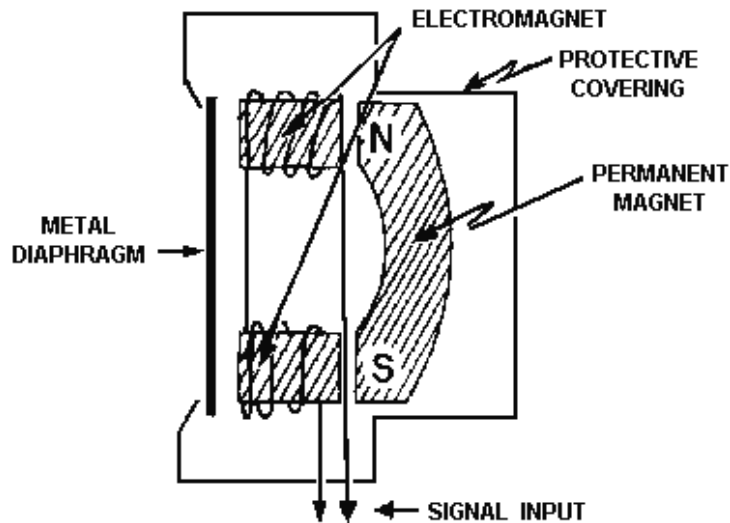

Figure 2-32.—Headphone.

As compared to permanent magnet speakers, standard headphones are considered to be high-impedance devices. Headphone electromagnets are normally wound with many turns of small wire, which provide the larger impedance. Because of the physically small size and inflexibility of the metal diaphragm, the headphones often give poor response to the lower audio frequencies. In the voice range of audio, most standard issue headphones are adequate.

SUMMARY

In this chapter you learned transmitter and receiver fundamentals. We also discussed modes of operation and special controls circuits. Let's review some of these areas.

A **HARMONIC** is an exact multiple of the fundamental frequency. Even harmonics are 2, 4, and so on, times the fundamental. Odd are 3, 5, and so on, times the fundamental frequency.

A **SUBHARMONIC** is an exact submultiple of the fundamental frequency. Even subharmonics are one-half, one-quarter, and so on. Odd subharmonics are one-third, one-fifth, and so on, of the fundamental frequency.

SUPPRESSION is the process of eliminating an undesired portion of a signal.

MULTIPLEXING is a method for simultaneous transmission of two or more signals over a common carrier wave.

An **ORDER-WIRE CIRCUIT** is a circuit between operators used for operations control and coordination.

RECEPTION is when an electromagnetic wave passes through a receiver antenna and induces a voltage in that antenna.

DETECTION is the separation of low-frequency (audio) intelligence from the high (radio) frequency carrier.

REPRODUCTION is the process of converting electrical signals to sound waves. This sound is speech, music, and so on.

SENSITIVITY of a receiver is the ability to reproduce weak signals. The greater the receiver sensitivity, the weaker the signal that will be reproduced.

Receiver **SELECTIVITY** is the ability to select the desired signal and reject unwanted signals.

NOISE SILENCER, NOISE SUPPRESSOR, or NOISE LIMITER, are circuits that clip the peaks of the noise spikes in a receiver.

SQUELCH is a circuit that cuts off the output of a receiver when there is no input.

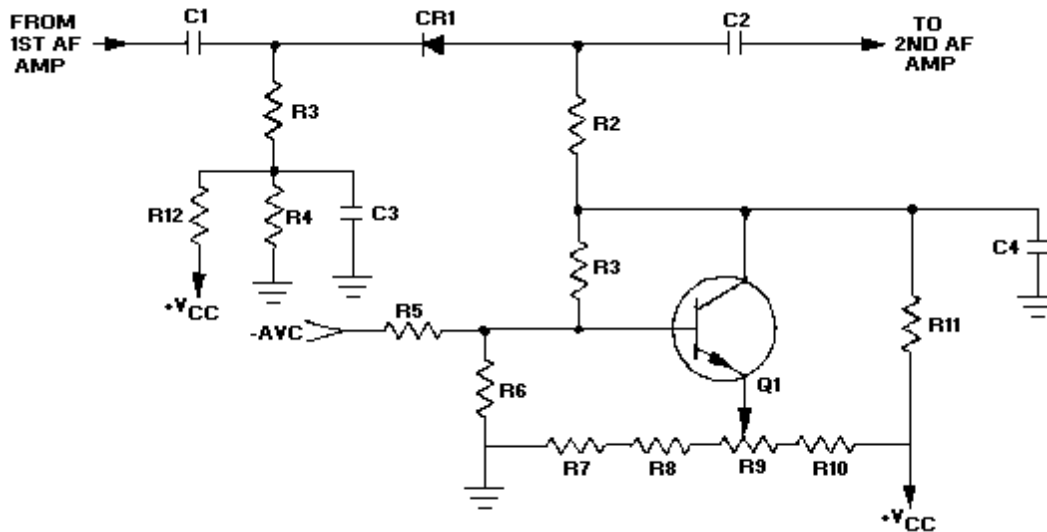

A **BALANCED-PHASE DETECTOR** or **PHASE-DISCRIMINATOR** is a circuit that controls the oscillator frequency (afc).

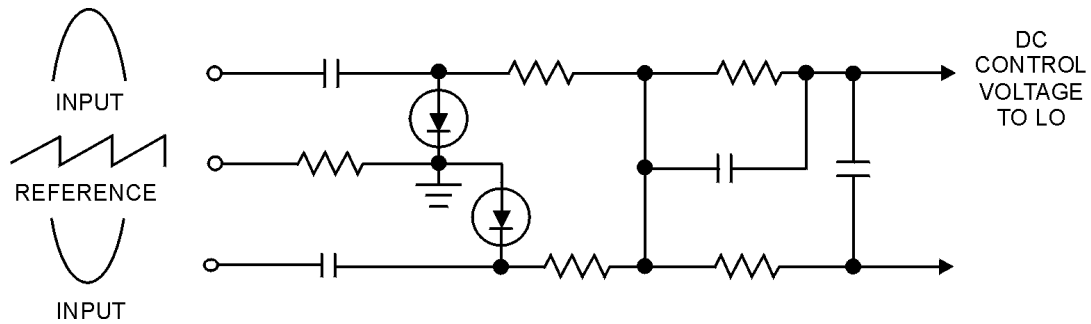

FREQUENCY SYNTHESIS is a signal-producing process through heterodyning and frequency selection.

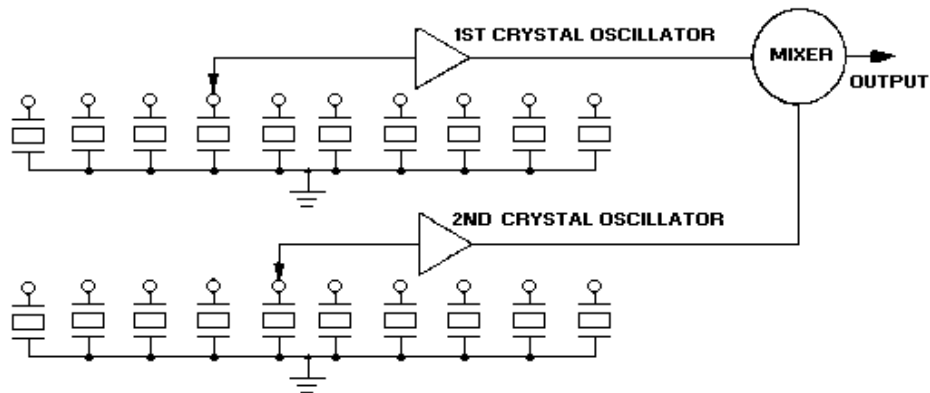

A **PERMANENT MAGNET SPEAKER** is one with a permanent magnet mounted on soft iron pole pieces.

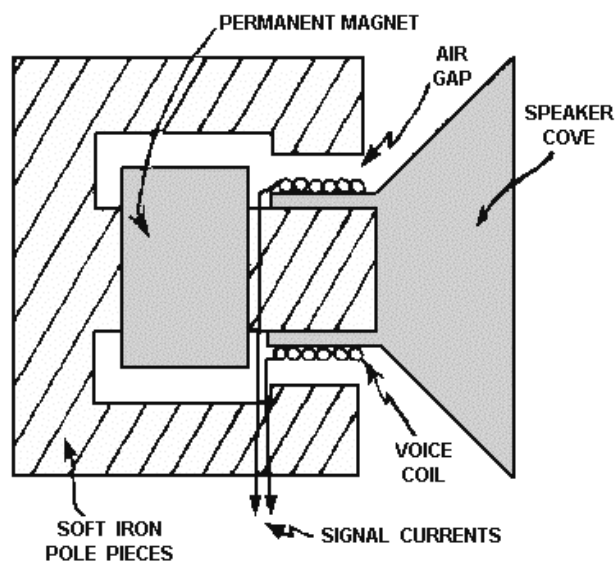

The **FIDELITY** of a receiver is the ability to accurately reproduce at its output the signal at its input.

GANGED TUNING is the process used to tune two or more circuits with a single control.

HETERODYNING is the mixing of the incoming signal with the local oscillator frequency. This produces the two fundamentals and the sum and difference frequencies.

An **IMAGE FREQUENCY** is an undesired frequency capable of producing the desired frequency through heterodyning.

AUTOMATIC VOLUME/GAIN CONTROL is a circuit used to limit variations in the output signal strength of a receiver.

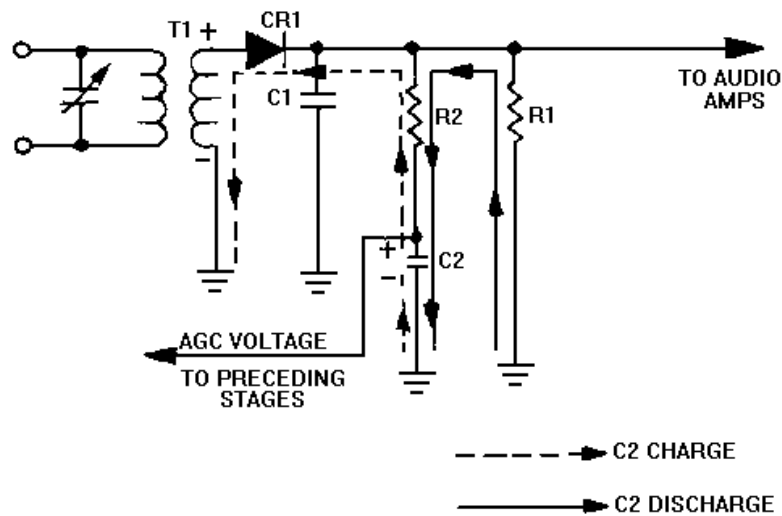

FADING is the variations in signal strength at the antenna of a receiver.

REVERSE AGC is when an amplifier is driven toward cutoff.

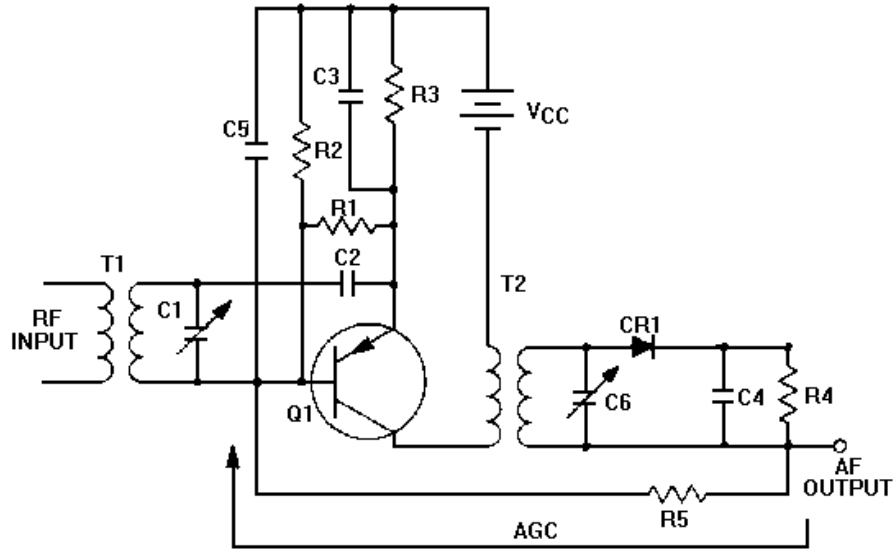

FORWARD AGC is when an amplifier is driven toward saturation.

A **BEAT-FREQUENCY OSCILLATOR** is an additional oscillator used in a receiver when the receiver is receiving a cw signal and provides an audible tone.

ANSWERS TO QUESTIONS Q1. THROUGH Q26.

- A1. *Am, fm, cw, ssb.*
- A2. *It generates an rf carrier at a given frequency within required limits.*
- A3. *Power amplifier.*
- A4. *It converts audio (sound) into electrical energy.*
- A5. *When no modulation is present.*
- A6. *It is an exact multiple of the basic or fundamental frequency.*
- A7. *600 megahertz.*
- A8. *To obtain higher carrier frequencies.*
- A9. *It saves power and frequency bandwidth.*
- A10. *For operator-to-operator service messages and frequency changes.*
- A11. *Reception, selection, detection, and reproduction.*
- A12. *Sensitivity, noise, selectivity, and fidelity.*
- A13. *Heterodyning.*
- A14. *To extract the modulating audio signal.*
- A15. *Wide bandpass.*
- A16. *A special type of detector and a carrier reinsertion oscillator.*
- A17. *Attenuates the strong and amplifies the weak.*
- A18. *To limit unwanted variations in the output.*
- A19. *Weak signals produce bias, which could result in no usable receiver output.*
- A20. *Dagc does not attenuate weak signals.*
- A21. *It is heterodyned with the rf to produce an audio frequency.*
- A22. *It eliminates noise when no signal is being received.*
- A23. *It controls the amount of bass and treble response.*
- A24. *It is used to achieve maximum selectivity.*
- A25. *It is used to accurately control the frequency of the oscillator.*
- A26. *The process of selecting and/or heterodyning frequencies to produce a signal frequency.*

CHAPTER 3

FUNDAMENTAL SYSTEMS EQUIPMENT

LEARNING OBJECTIVES

Upon completion of this chapter you will be able to:

1. State the function of a radio communications handset, a radio set control, and a transfer switchboard.
2. Describe the functions and interrelationships of a radio transmitter.
3. Describe the functions of receive and transmit multicouplers.
4. Describe the differences between the codes used for manual telegraphy and teletypewriter transmissions.
5. Describe the two basic modes of teletypewriter operation.
6. Describe the two types of teletypewriter dc circuits.
7. State the two types of radio teletypewriter shift systems and describe their basic differences.
8. Describe the functions and interrelationships of radio-frequency-carrier shift send and receive systems.
9. Describe the signal flow in an audio-frequency-tone shift system.
10. State the function of the tone terminal set in an audio-frequency-tone shift system.
11. Describe the basic multiplexing process.
12. Describe the three operations performed by a facsimile system.
13. Describe the functions and interrelationships of facsimile equipment.
14. Describe the countermeasures that can be used to eliminate compromising emanations.

EQUIPMENT PURPOSES

A communications system is a collection of equipment used together to do a specific job. You may see this equipment used to send or receive voice communications, or both, or to send, receive, or send and receive teletypewriter information.

Figure 3-1 is a basic block diagram of a voice system. You can see how this equipment is interconnected to form a basic communications system. We are going to look at several of the equipment blocks in detail.

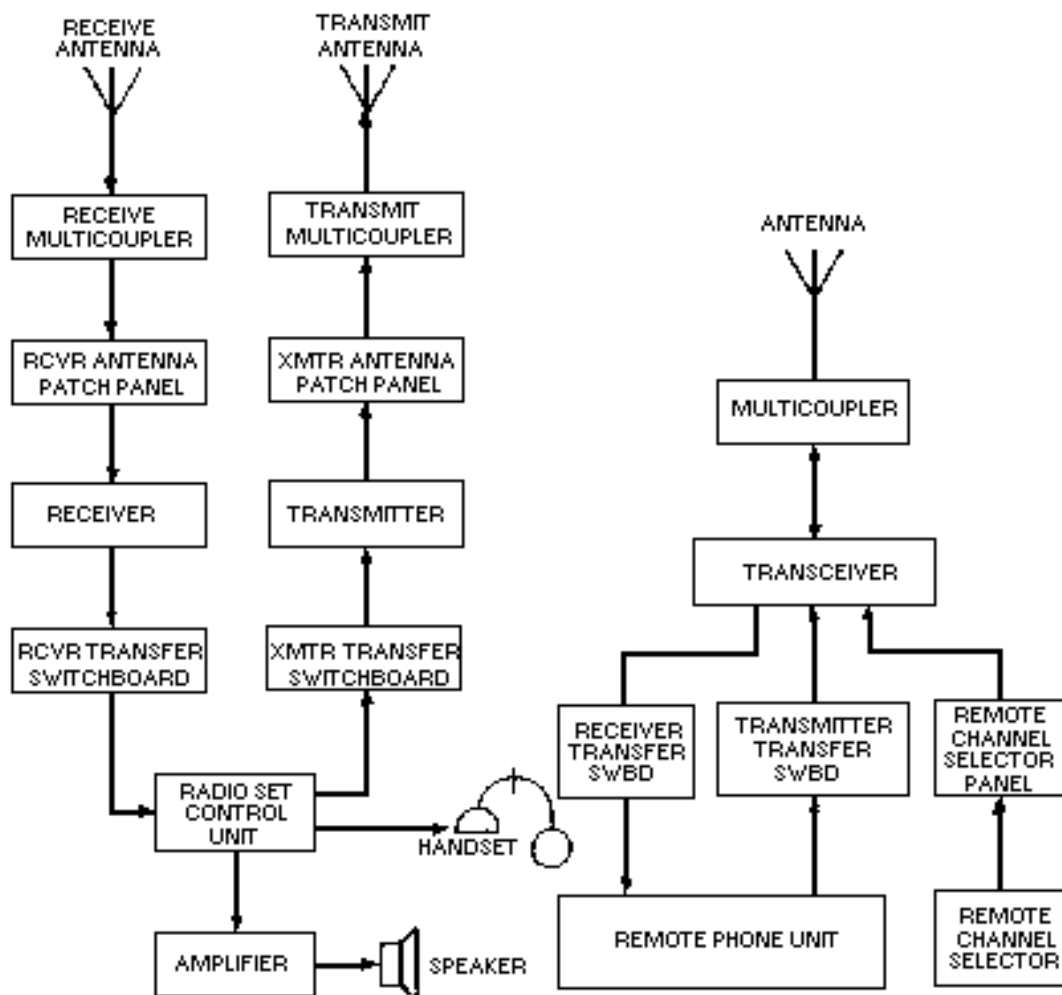

Figure 3-1.—Voice system.

HANDSET

The handset converts acoustical energy (your voice) to electrical energy for use in modulating a radio transmitter. It also converts electrical energy to acoustical energy for reproduction of a received signal. When the push-to-talk button is depressed on the handset, the dc keying circuit to the transmitter is closed, placing the transmitter on the air.

Handsets are normally connected to a radio set control unit.

RADIO SET CONTROL UNIT

The radio set control unit shown in figure 3-2 provides a capability to remotely control some radiophone transmitter functions and the receiver output. Some of the controls are used for turning the transmitter on and off. Others are used for voice modulating the transmission (or keying when cw operation is desired). You can even control the audio output level of the receiver and silence the receiver when transmitting.



Figure 3-2.—Radio set control unit.

Under standard operating conditions up to four of these units can be used in parallel with a single transmitter and receiver group to provide additional operating positions. This setup is often found aboard ship where a transmitter and/or receiver is controlled and operated from several locations such as the bridge or the combat information center.

TRANSFER SWITCHBOARDS

A transmitter transfer switchboard provides the capability to transfer remote control station functions and signals to transmitters. Figure 3-3 is a representative transfer switchboard that provides the capability for selectively transferring any one, or all, of ten remote control station functions and signals to any one of six transmitters. The cabinet has ten rotary switches arranged in two vertical rows of five each. Each switch has eight positions. The circuitry is arranged so that you cannot parallel transmitter control circuits; that is, you cannot connect more than one transmitter to any remote control location.

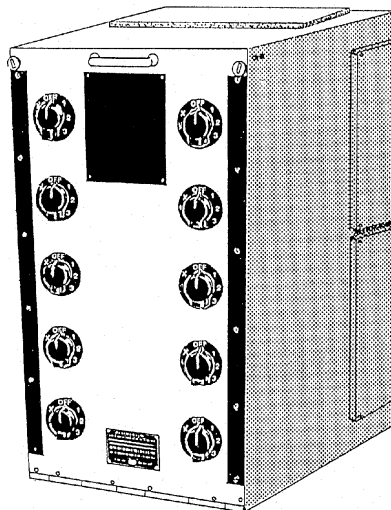

Figure 3-3.—Transmitter transfer switchboard.

Each switch operating knob corresponds to a remote control station. Each switch position (1 through 6) corresponds to a transmitter. One switch position, X, provides for transfer of all circuits to additional

transmitter transfer switchboards when more than six transmitters are installed in the system. When the rotary switch is placed in the OFF position the remote control station is removed from the system.

Let's look at an example of one transfer switchboard application. When remote control station number two is to have control of transmitter number three, the switch knob designated number two is rotated until its pointer indicates position three on its dial plate.

The receiver transfer switchboard permits the operator to transfer the audio output from a receiver to a remote control station audio circuit. A representative receiver transfer switchboard is shown in figure 3-4. This switchboard contains ten seven-position switches. Each switch is connected to a remote control station, and each switch position (one through five) is connected to a receiver.

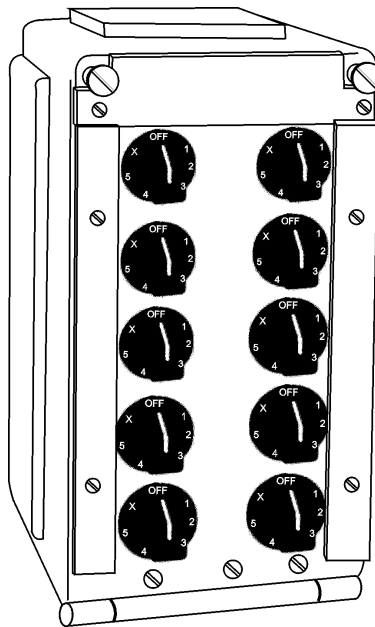

Figure 3-4.—Receiver transfer switchboard.

The X position on each switch allows transfer of circuits to additional switchboards just like with the transmitter transfer switchboard.

- Q1. What are the basic functions of a handset?*
- Q2. What capability does a transmitter transfer switchboard provide?*
- Q3. What function does a receiver transfer switchboard perform?*

TRANSMITTERS

You learned earlier that transmitters may be simple with low power (milliwatts) capabilities. These may be used to send voice messages a short distance. You may also use highly sophisticated units that use thousands (even millions) of watts of power to send many channels of data (for example voice, teletypewriter, television, telemetry) simultaneously over long distances. Let's look at a complete transmitter set.

Radio Transmitting Set

The applications, configurations, and components you will become familiar with here are typical of most general purpose transmitter systems used in the Navy. A specific transmitter is used only for ease of illustration and example.

We will be discussing a 1,000 watt, single-sideband radio transmitting set that is available to the Navy in any one of four setups. The normal configuration has a transmitter capable of voice, continuous wave, and radio teletypewriter transmissions in the 2- to 30-megahertz frequency range. Exact spacing and number of channels available within the frequency spectrum, modes of operation, and frequency range depend on the model of equipment and how it is configured for use. Stack or rack mounting is used in a ship or shore permanent installation with accessory equipment (for example an rf amplifier, coupler control unit, or power supply) to form a complete communications system. One of three different three-phase primary power sources can be used (depending on whether the transmitter is land, air, or shore based) to provide operating power to the set. Combinations available are 115 volts, 400 hertz; or 208/440 volts, 60 hertz.

General Description

Figure 3-5 shows the major units of this set. They are the radio transmitter, the radio frequency amplifier, the power supply, and the electrical equipment shock mount base. An antenna coupler group (consisting of a coupler and coupler control unit) is normally used to match the impedance of the system to a 50-ohm transmission line. If you want to operate with any 50-ohm antenna system, terminating connections are available.

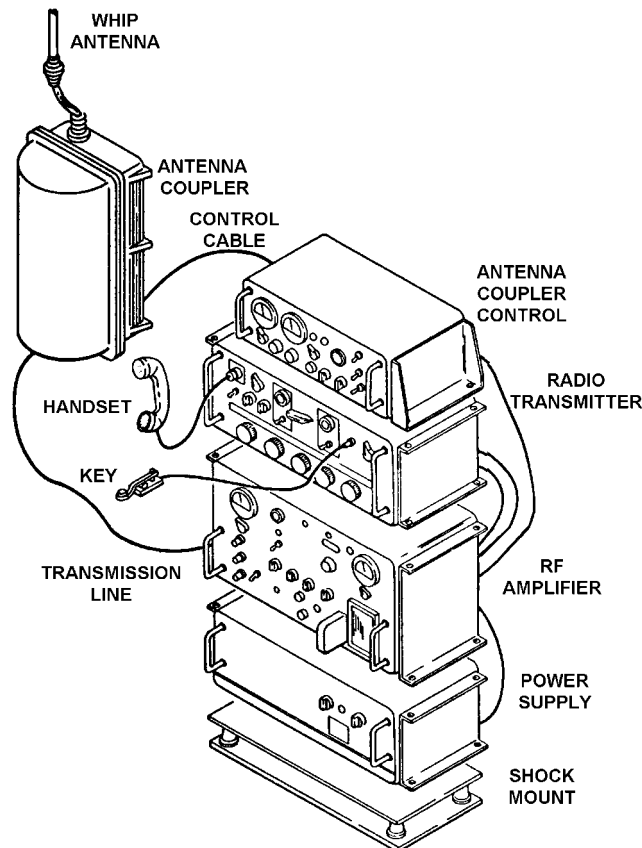

Figure 3-5.—Radio transmitting set.

The transmitter unit provides an upper sideband (usb), lower sideband (lsb), independent sideband (isb), cw, fsk, or compatible AM signal. The output of the transmitter has enough power to drive the radio frequency amplifier.

Depending on the model, the transmitter tunes across the frequency range in 100- or 500-hertz increments. Digital circuitry is used to accomplish this process. Transmitter outputs are also applied to the rf amplifier to automatically tune it to the correct frequency. We will go through a detailed breakdown of the transmitter unit later in this chapter.

RADIO FREQUENCY AMPLIFIER.—The rf amplifier unit is a two-stage linear power amplifier that produces an output of 1,000 watts with a nominal input of 100 milliwatts. Nineteen frequency bands are used to cover the operating frequency range. The operating band is automatically selected by digital coding generated by the transmitter. The code controls two motor-driven band switch assemblies. Automatic control circuits protect the unit against overload and compensate for variations in system gain, mode of operation, and loading.

All low voltages required for operation (except two of the relay control voltages) are internally produced. The high voltages required in the amplifier stages are produced by the associated power supply (when using 60 hertz primary power) or the optional internally mounted power supply (when using 400 hertz primary power).

Let's take a look at figure 3-6 to see all the operating controls and indicators located on the front panel. Some controls are used only for initial setup and are protected by a hinged access cover. All connections are made at the rear of the case. The amplifiers and the associated interstage broadband transformer assemblies are cooled by forced ventilation. Cooling air is drawn through a filter on the front panel and exhausted through a port on the rear of the case. You should always take particular care to clean or replace any filter in electronic equipment as a regular part of your preventive maintenance program.

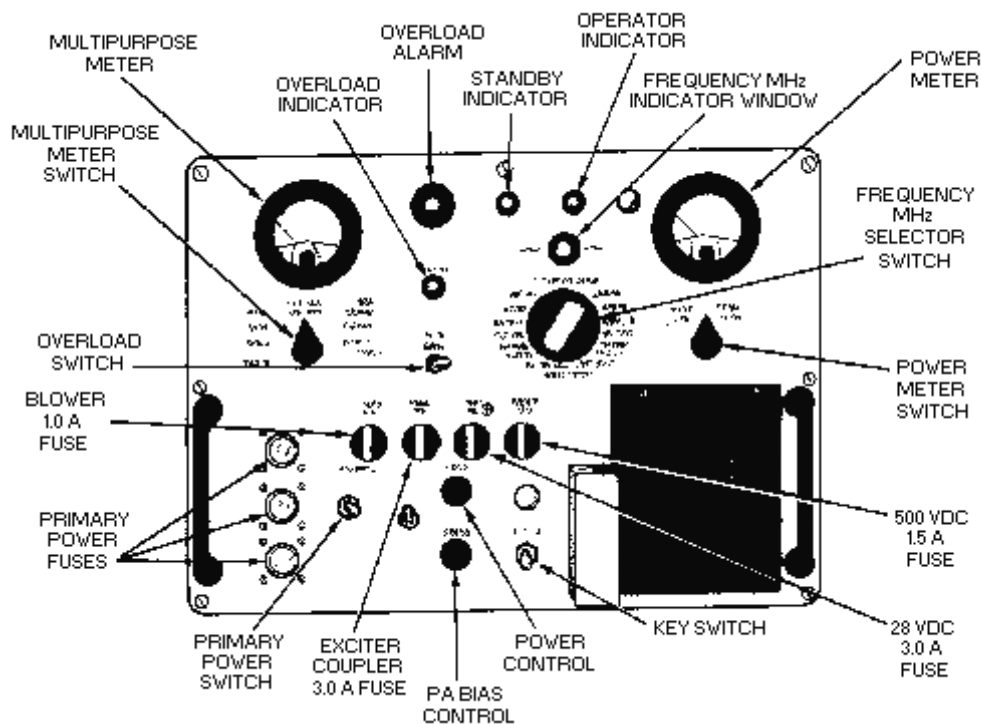

Figure 3-6.—Rf amplifier unit.

POWER SUPPLIES.—One power supply produces operating voltages for the amplifier when operating from a 60-hertz power source. All components of the power supply, except the power transformers, are mounted on a chassis and panel assembly that is hinge-mounted to a metal case. The power transformers are constructed as part of the case and there are no operating controls.

The other power supply produces operating voltages for the rf amplifier when a 400-hertz, three-phase, 115-volt primary power source is used.

ANTENNA COUPLER GROUP.—The antenna coupler group is an automatic antenna tuning system. However, the equipment design includes provisions for manual or semiautomatic tuning. This makes the system adaptable for use with other radio transmitters. The manual tuning capability is useful when a failure occurs in the automatic tuning circuitry. Tuning can also be accomplished without the use of rf power (SILENT TUNING). This method is useful in installations where radio silence must be maintained except for brief transmission periods.

The antenna coupler matches the impedance of a 15-, 25-, 28-, or 35-foot whip antenna to a 50-ohm transmission line at any frequency in the 2- to 30-megahertz range. Control signals from the associated antenna coupler control unit automatically tune the matching network in less than five seconds. During manual and silent operation, tuning is accomplished by the operator with the controls mounted on the antenna coupler control unit. A low power (not to exceed 250 watts) cw signal is required for tuning. Once tuned, the coupler is capable of handling 1,000 watts peak envelope power (pep).

The coupler is enclosed in an aluminum, airtight, pressurized case. Six mounting feet enable the unit to be attached to the mast of a ship at the base of a whip antenna. The coupler is pressurized with dry nitrogen to aid internal heat transfer and to prevent corona and arcing. All components of the coupler are secured to a chassis that is mounted to the case so that an air duct exists between the chassis plate and the

case. An internal fan circulates the nitrogen over and through the heat-producing elements and then through the air duct. While passing through the air duct, the nitrogen loses its heat to the bottom of the case. This heat is then transferred by convection through fins on the bottom of the case and by conduction through the mounting feet.

Figure 3-7 shows the antenna coupler control unit. This unit provides the power and control signals required to tune the coupler. Control signals are either automatically produced by the coupler control when a tune cycle is initiated or manually produced with the front panel controls.

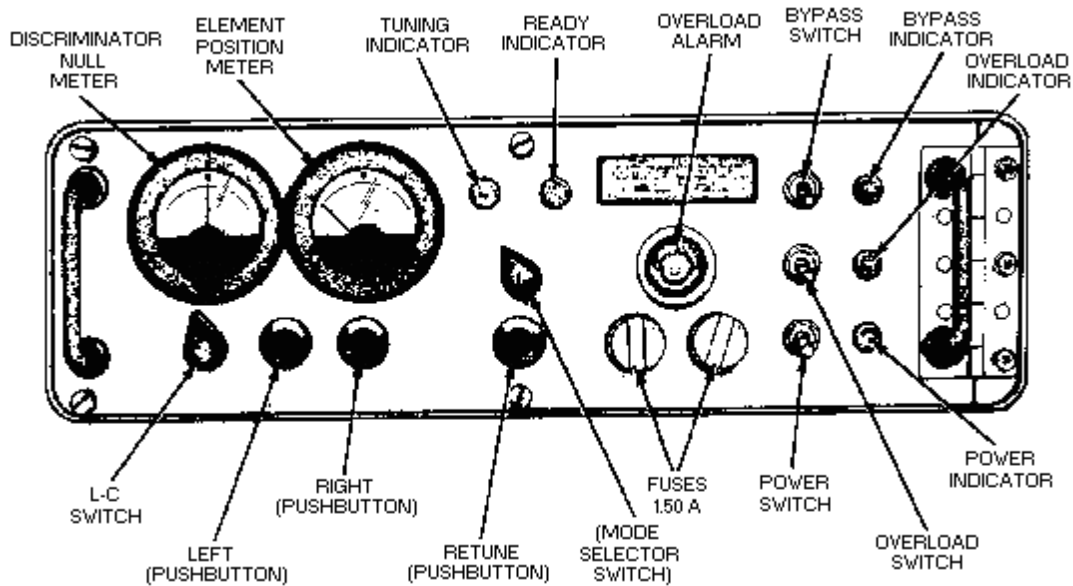

Figure 3-7.—Antenna coupler control unit.

All dc operating voltages are produced from a 115-volt, 48- to 63- or 350- to 450-hertz, single-phase primary power source. Meter and protection circuits are used to give you complete control of the coupler from the remotely positioned coupler control unit.

- Q4. If the rf amplifier discussed has an 80 milliwatt input, what would be the maximum output?
- Q5. What are the tuning modes for the coupler group discussed?
- Q6. What is the purpose of an antenna coupler?
- Q7. Why is the coupler pressurized with nitrogen?

RADIO TRANSMITTER.—Figure 3-8 shows the front panel of the radio transmitter unit. The radio transmitter accepts audio or coded intelligence and uses it to modulate one of 280,000 possible operating radio frequencies in the 2.0- to 29.999-megahertz frequency range. Tuning is accomplished digitally by means of five control knobs and a switch located on the front panel. The transmitter has a normal rf output level of at least 100 milliwatts and is designed to be used with an associated rf power amplifier.

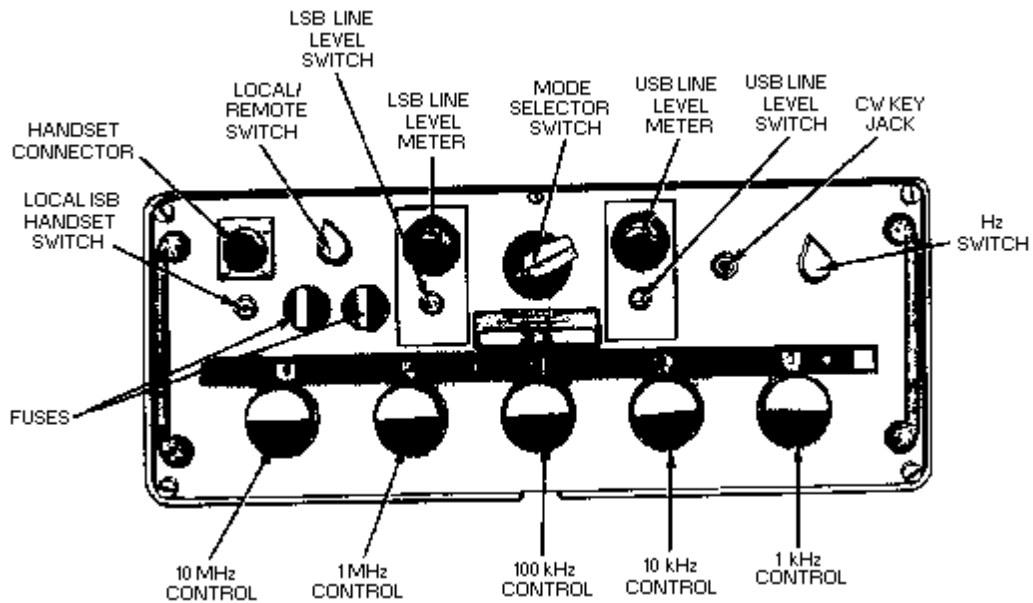

Figure 3-8.—Radio transmitter unit.

When the AM and ssb transmit modes of operation are used, the output from a handset is applied to the transmitter. The voice signals are amplified and used to modulate a 500-kilohertz local carrier that produces a 500-kilohertz IF. The resulting double sideband signal is filtered in the AM mode, amplified, and converted by a triple-conversion process to the desired rf operating frequency. The rf signal is amplified to a nominal 100 milliwatt level. In cw operation, the 500-kilohertz local carrier is inserted directly into the IF amplifiers. The signal is further processed in the same manner as the voice signals in the AM or ssb modes of operation. In fsk operation, the loop current is converted to audio frequencies representing marks and spaces. These audio signals are applied to the audio circuits of the transmitter. Thereafter, these signals are processed in the same manner as the voice signals in AM or ssb modes of operation. A typical radio transmitting set block diagram is shown in figure 3-9.

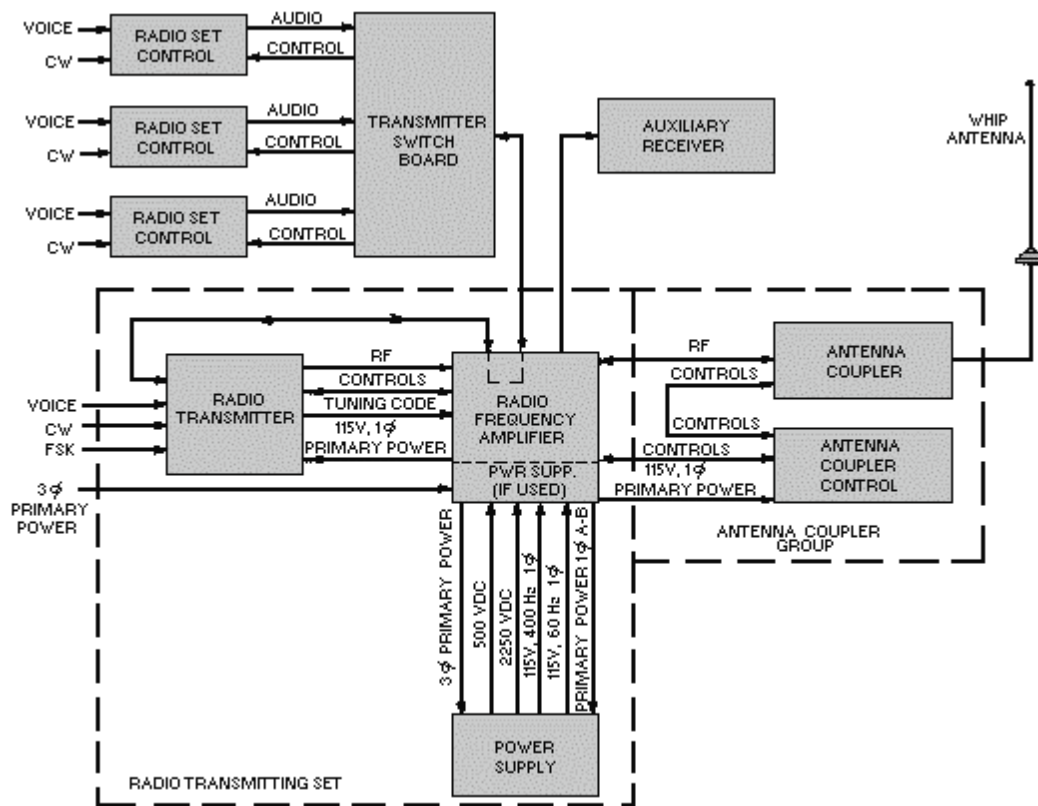

Figure 3-9.—Typical radio transmitting set block diagram.

RECEIVERS

The receiver we will discuss is a triple-conversion superheterodyne, tunable from 2 to 30 megahertz. Triple conversion uses three IF frequencies to give better adjacent-channel selectivity and greater image-frequency suppression. Figure 3-10 shows the front panel of this receiver where tuning is done digitally by five controls and a switch. A display window directly above each control provides a digital readout of the frequency setting. The displayed frequency can be changed in 1-kilohertz increments. The front panel switch allows the operating frequency to be changed in 100- or 500-hertz increments depending on the model. This will provide you with 280,000 discrete frequencies locked to a very accurate frequency standard. You can continuously tune each 1,000-hertz increment by selecting the VERNIER position of the hertz switch. When using the vernier, the full accuracy of the frequency standard is sacrificed. The receiver demodulates and provides audio outputs for the lsb, usb, isb, AM, cw, and fsk types of received signals.

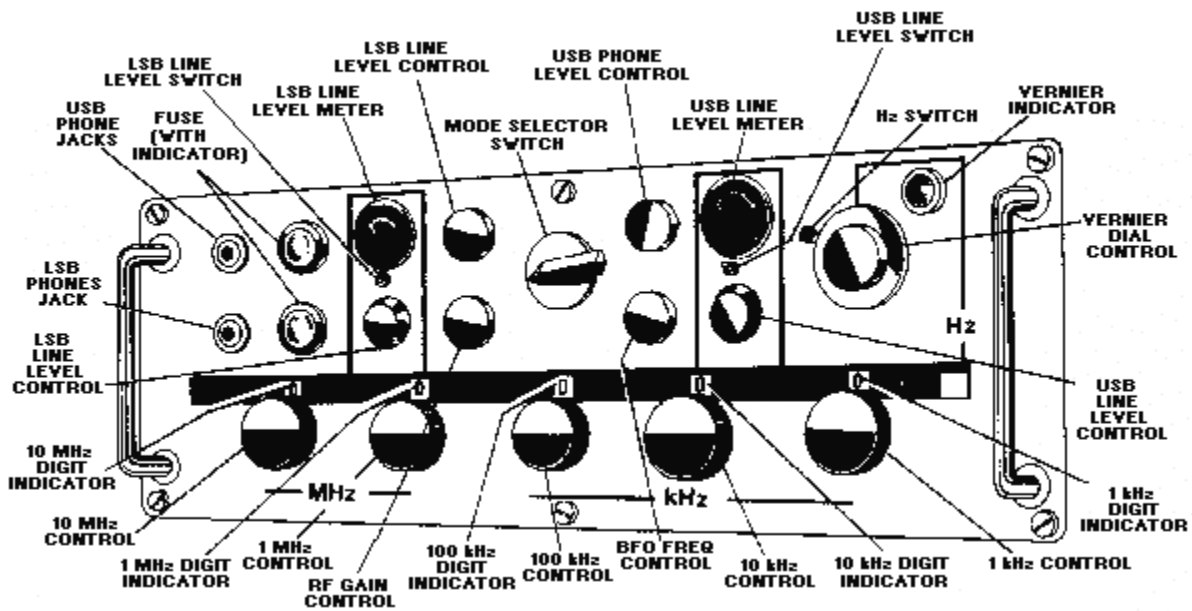

Figure 3-10.—Typical radio receivers

Q8. What are the transmitter operating modes?

Q9. What type of tuning does the receiver use?

ANTENNA DISTRIBUTION SYSTEMS

Receiving antenna distribution systems operate at low power levels and are built to fit a standard 19-inch rack. Each piece of distribution equipment is fitted with termination or patch fittings designed for ease of connecting and disconnecting. A basic patch panel is shown in figure 3-11. Even a fundamental distribution system has several antenna transmission lines and several receivers. Normally a patch panel consists of two basic patch panels. One panel is used to terminate the antenna transmission lines and the other the lines leading to the receivers. Any antenna can be patched to any receiver through the use of patch cords.

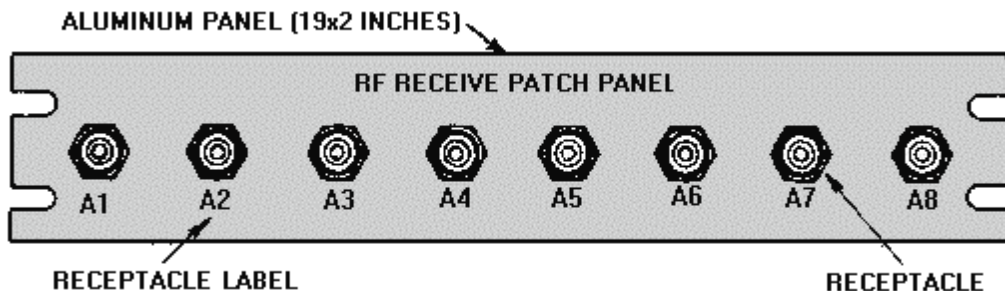

Figure 3-11.—Basic rf receive patch panel.

Many distribution systems are more complex. A complex distribution system to cover most situations is illustrated in figure 3-12. In this system you can patch four antennas to four receivers, or you can patch one antenna to more than one receiver via the multicouplers (multicouplers are covered later in

this chapter). You can also patch rf and audio from one compartment to another. A frequency standard is connected (through a distribution amplifier not shown) to the receivers.

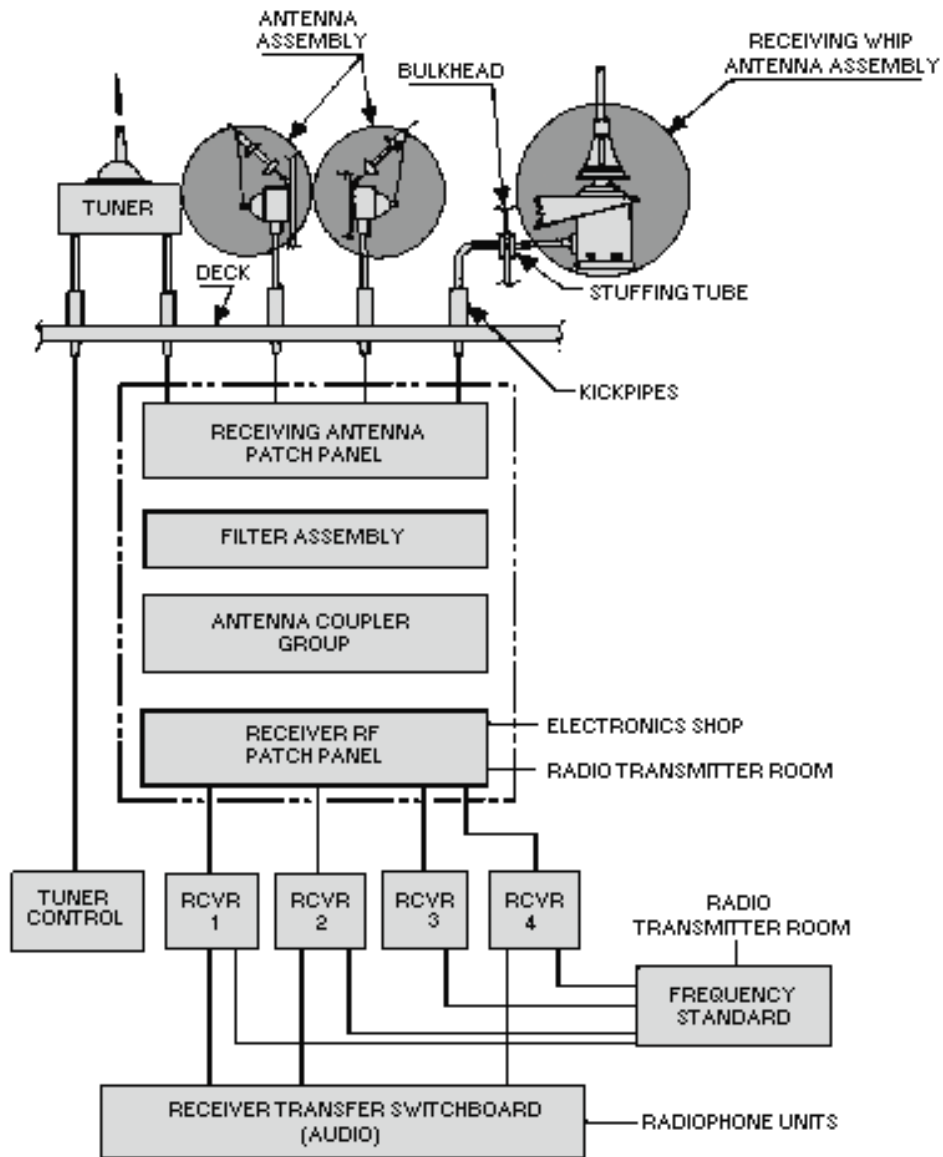

Figure 3-12.—Complex distribution system.

Transmitting antenna distribution systems perform the same functions as receiving systems. However, because of the higher power levels, design and fabrication problems are more difficult. The ideal design would be to have all the transmission lines designed for the highest power level. But because high-power patch cords are expensive, large, and difficult to handle, this approach is seldom followed.

In practice, the basic patch panel we just looked at in figure 3-11 is practical for low power levels. Another type of transmitter patch panel is shown in figure 3-13.

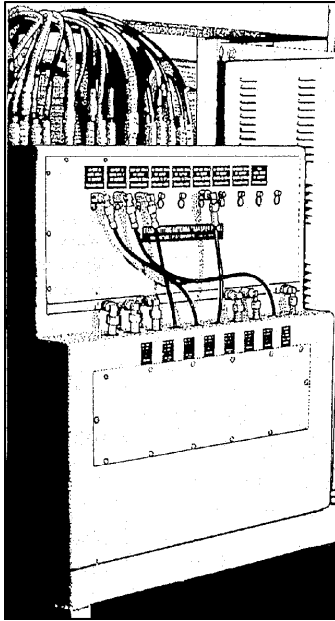

Figure 3-13.—Transmitting antenna patch panel.

This type of transmitting antenna patch panel is interlocked with the transmitter so that no open jack connection can be energized and no energized patch cord can be removed. This provides you with a greater degree of personnel and equipment safety.

Receive Multicoupler

Figure 3-14 is a filter assembly multicoupler that provides seven radio frequency channels in the 14-kilohertz to 32-megahertz range. Any or all of these channels may be used independently of any of the other channels, or they may operate simultaneously. You can make connections to the receiver by means of coaxial patch cords, which are short lengths of cable with plugs attached to each end.

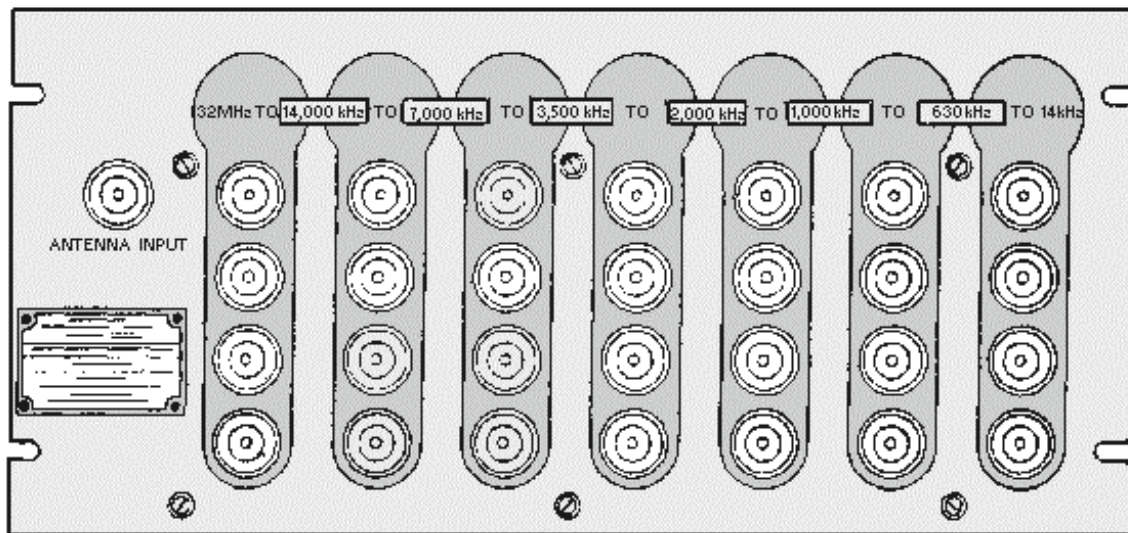

Figure 3-14.—Electrical filter assembly.

A set of nine plug-in type filter assemblies is furnished with the equipment and covers the entire vlf, lf, mf, and hf bands. Only seven of the assemblies may be installed at one time, and you have the option of selecting those you need to cover the most used frequency bands.

Figure 3-12 illustrates how the filter assembly is used in combination with other units to pass an rf signal from an antenna to one or more receivers.

Transmit Multicouplers

Most multicouplers for the hf range are designed for use with either transmitters or receivers, although some are used with both. There are a large number of channels in a multicoupler so that many transmitters can be used at the same time on one antenna. This is especially true in the 2- to 12-megahertz range.

Figure 3-15 shows you an antenna coupler group designed primarily for shipboard use. Each coupler group permits several transmitters to operate simultaneously into a single, associated, broadband antenna. You can see this reduces the total number of antennas required in the limited space aboard ship.

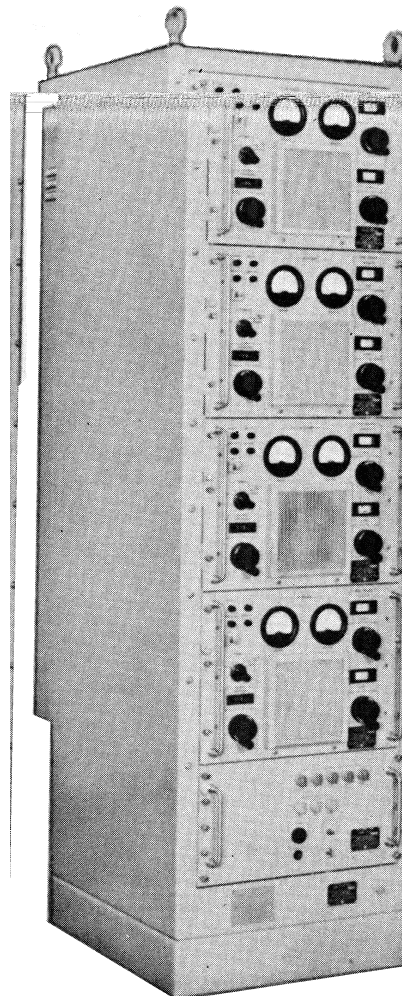

Figure 3-15.—Antenna coupler group.

These antenna coupler groups provide a coupling path of prescribed efficiency between each transmitter and its associated antenna. They also provide isolation between transmitters, tunable bandpass filters, and matching networks.

TELETYPEWRITER AND FACSIMILE EQUIPMENT

In previous areas we have discussed different methods of voice communications. At times, however, the message is too long for practical transmission by voice. To get information or an idea across to another person far away, you may also need a chart, map, or photograph. Teletypewriter (tty) and facsimile equipment allow us to do just that, with ease. Let's see how this is done.

BASIC PRINCIPLES

To give you an idea of how intelligence is sent via teletypewriter, let's take a look at the manual telegraph circuit. This circuit, shown in figure 3-16, includes a telegraph key, a source of power (battery), a sounder, and a movable sounder armature. If the key is closed, current flows through the circuit and the armature is attracted to the sounder by magnetism. When the key is opened, the armature is retracted by a spring. With these two electrical conditions of the circuit, intelligence can be transmitted by means of a teletypewriter code. These two conditions of the circuit are referred to as MARKING and SPACING. The marking condition occurs when the circuit is closed and a current flows; the spacing condition occurs when it is open and no current flows.

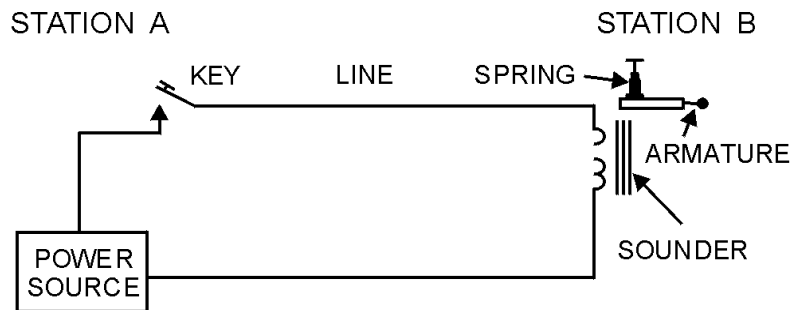

Figure 3-16.—Manual telegraph circuit.

If the key at station A is replaced by a transmitting teletypewriter and the sounder arrangement at station B is replaced by a receiving teletypewriter, the basic teletypewriter circuit (loop) shown in figure 3-17 is formed.

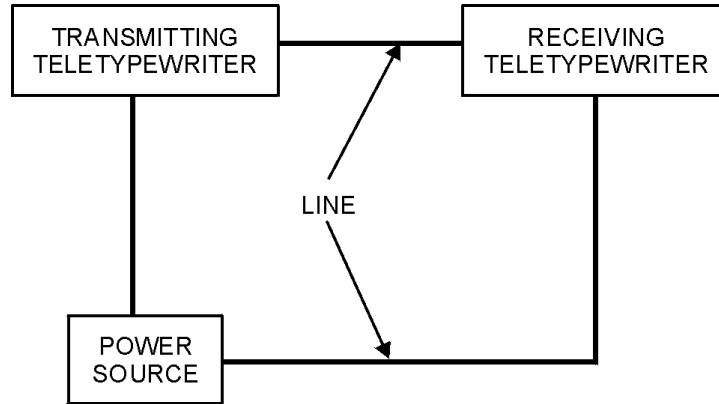

Figure 3-17.—Simple teletypewriter circuit.

If a teletypewriter signal could be drawn on paper, it would resemble figure 3-18. This is the code combination for the letter R. Shaded areas show intervals during which the circuit is closed, and the blank areas show the intervals during which the circuit is open. The signal has a total of seven units. Five of these are numbered and are called INTELLIGENCE units. The first and last units of the signal are labeled START and STOP. They are named after their functions: the first starts the signal, and the last stops it. These are a part of every teletypewriter code signal: the START unit is always spacing, and the STOP unit is always marking.

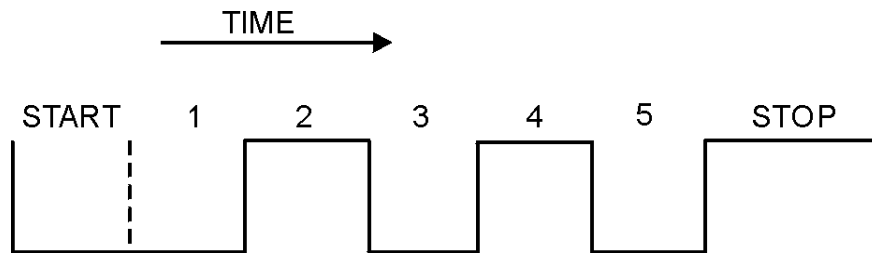

Figure 3-18.—Mark and space signals.

The teletypewriter signal is theoretically a perfect signal. The time between each unit remains the same during transmission of the signal. The shift from mark to space (and vice versa) is called a TRANSITION. A transition occurs at the beginning and end of each unit when it shifts from mark to space or space to mark; a character may have two, four, or six transitions.

When figuring the time duration of a signal character, no allowance for transition time is made since the transition is instantaneous and is considered to have zero time duration. The time duration for each unit is measured in milliseconds.

Q10. What is the function of an antenna patch panel?

Q11. What are the functions of a multicoupler?

Q12. What are the terms used to describe an open or closed telegraph circuit?

Q13. How many units are in a tty signal and what are they?

Codes

Two of the codes the Navy uses are found in manual telegraphy and in teletypewriter operation. One is very easy to understand while the other is more complex. Let's look at these two types and how they work.

MANUAL TELEGRAPHY.—In manual telegraphy, the most widely used code is the Morse code. In this code, two distinctive signal elements are employed—the dot and the dash. The difference between a dot and a dash is its duration, a dash being three times as long as a dot. Each character is made up of a number of dots and/or dashes. The dot and dash elements making up any character are separated from each other by a time interval equal to the duration of one dot. The time interval between the characters for each word is equal to the duration of three dots. The interval between words is equal to seven dots. (A signal-man uses the Morse code to send visual flashing-light messages. The radioman uses the Morse code to send messages electrically.)

TELETYPEWRITER MESSAGE TRANSMISSION.—In teletypewriter operation, the code group for each character is of uniform length. Since the Morse code is an uneven length code, it cannot be used in teletypewriter operation without additional code converters.

The FIVE-UNIT (five-level) CODE has been the most commonly used in modern printing telegraphy and is universally used in teletypewriter operation. This is also known as the Baudot code. The mechanical sending device in the teletypewriter divides the sending time for each character into five short code elements (impulses) of equal duration. The five-unit code is an example of what is called an even length or constant length code (one in which the number of signal elements for a character is the same for every character and the duration of each element is constant). In the five-unit code, each character consists of a combination of five signal elements; each element may be either a mark or a space. A total of thirty-two combinations of signal elements are possible with this arrangement.

The thirty-two possible combinations available from the five-unit code are insufficient to handle the alphabet and numbers since twenty-six combinations are required for the letters of the English alphabet alone. This leaves only six combinations for numerals, symbols, or nonprinting functions. This number of combinations is obviously inadequate; therefore, two of the thirty-two combinations are used as shift signals. The shift signals are often referred to as case-shift signals (one case is a letter shift, and the other a figure shift.) These two shift signals permit the remaining code combination to be used as letter-shift signals for letters and as figure-shift signals for numerals, function signs, and so forth. When a letter shift is transmitted, it sets the receiving instrument in a condition to recognize any letter signal combination. It will recognize letter combinations until a figure shift is received. Then the receiving instrument sets itself in a condition to recognize any figure signal combination received. The interpretation of a signal combination is determined by the previous shift signal. This plan enables 30 of the 32 available combinations to have two meanings.

Q14. There are not enough combinations of the five-unit code to handle the alphabet, symbols and so forth. What is used to increase the number of available code combinations?

Modes of Operation

The two basic modes of teletypewriter operation are ASYNCHRONOUS (start-stop) and SYNCHRONOUS. The most common mode used in teletypewriter operation is the start-stop mode. Synchronous operation is used more in high-speed data systems. Let's examine their differences.

ASYNCHRONOUS.—In the start-stop mode of operation, the receiving device is allowed to run for only one character. It is then stopped to await the reception of a start signal indicating the next character is

about to start. In this manner any difference in speed between the transmitting and receiving devices can accumulate only during the duration of one character. However, you should note that a penalty must be paid for this advantage. The length of each character must be increased to include a unit (element) to start the receiving device and another to stop it.

The start unit precedes the first intelligence unit and is always a space signal. Its purpose is to start the receiving machine. The stop unit follows the last code unit and is always a mark signal. Its purpose is to stop the receiving machine in preparation for receiving the next character. The start unit must be equal to at least one unit of the code. The standard mode uses a stop unit that is 1.42 times the length of one intelligence unit. It is common practice to refer to a code unit as an element and to use the terms interchangeably. You will also hear duration of a unit referred to as the unit interval.

The length of time required to transmit the entire character is called the CHARACTER INTERVAL. Character interval becomes very important in some transmissions because certain items of equipment are character length conscious or code conscious. Stop unit intervals of various lengths are used or produced by various equipment (1.0, 1.27, 1.5, 1.96, 2.0, and so forth). Basically, the only difference between them is the length of time required to transmit one character.

SYNCHRONOUS.—Synchronous teletypewriter operation does not in all cases have to rely upon elements of the transmitted character to maintain proper position in relation to the receiving device. External timing signals may be used that allow the start and stop elements to be discarded. You will then see only the elements necessary to convey a character.

Synchronous systems have certain advantages over asynchronous systems. The amount of time taken to transmit stop and start elements is made available for information transmission rather than for synchronizing purposes. Only the intelligence elements are transmitted. In start-stop signaling, the ability of the receiving device to select the proper line signal condition is dependent upon signal quality. For example, suppose the stop-to-start transition arrives before it should; then, because of atmospheric conditions, all subsequent selection positions in that character will appear earlier in time in each code element. A synchronous system has a higher capability for accepting distorted signals because it does not depend on a start-stop system for synchronization.

Modulation Rate

Several terms are used to refer to teletypewriter modulation rates or signaling speeds. These include BAUD RATE, BITS PER SECOND, and WORDS PER MINUTE. Baud is the only term that is technically accurate. The other terms are either approximations or require explanation.

The word baud by definition is a unit of modulation rate. You will sometimes see it used to refer to a signal element, but this reference is technically incorrect. Baud rate is the reciprocal of the time in seconds of the shortest signal element. To find the modulation rate of a signal in bauds, you must divide the number 1 by the time duration of the shortest unit interval present in the signal. For example, 22 milliseconds (.022 seconds) is the time interval of the shortest unit in the five-unit code at 60 words per minute. To find the number of bauds corresponding to 60 words per minute, divide 1 by .022. Rounding off the result of the division gives us the number 45.5, which is the baud equivalent of 60 words per minute. Each increase in words per minute will correspondingly decrease the signal unit time interval. (The defense communications system standard speed for teletypewriter operation is 100 words per minute or 75 baud.)

Words per minute is used only when speaking in general terms for an approximation of speed. The term *100 words per minute* means 100 five letter words with a space between them can be transmitted in a 60-second period. However, you can obtain this nominal words-per-minute rate in several systems by

varying either modulation rate or the individual character interval (length). For this reason, the modulation rate (baud) method of reference rather than words per minute is used.

Formula for baud rate and words per minute are as follows

$$\text{Baud} = \frac{1}{\text{unit interval (in seconds)}}$$
$$\text{Words per minute} = \frac{\text{Baud rate}}{\text{unit code} \times 0.1}$$

BIT is an acronym for the words *binary digit*. In binary signals, a bit is equivalent to a signal element. Because of the influence of computer and data processing upon our language, modulation rate is sometimes expressed in bits per second. When you understand all signal elements being transmitted are of equal length, then the modulation rate expressed in bits per second is the same as the modulation rate expressed in baud.

Dc Circuits

You were told the two conditions *mark* and *space* may be represented by any convenient means. The two most common are NEUTRAL and POLAR operation. In neutral, current flow represents the mark, and no current flow represents the space; in polar operation, current impulses of one polarity represent mark, and impulses of the opposite polarity of equal magnitude represent the space.

NEUTRAL.—Neutral circuits make use of the presence or absence of current flow to convey information. A neutral teletypewriter circuit is composed of a transmitting device, a battery source to supply current, a variable resistor to control the amount of current, a receiving device, and a line for the transmission medium.

POLAR.—Polar operation differs from neutral operation in two ways. Current is always present in the polar system, and it is either positive or negative. A polar teletypewriter circuit contains the same items as a neutral circuit plus an additional "battery" source. The battery referred to here is not an actual battery but is a solid-state dc power supply. It provides variable current to the teletypewriters. The reason for having an extra battery source is because polar circuits use positive battery for marks and negative battery for spaces.

You will find in polar operation that the distortion of a signal is almost impossible through low line currents, high reactance, or random patching of signal circuits or equipment. In polar signaling when you experience a complete loss of current (a reading of zero on a milliammeter), you know you have line or equipment trouble; whereas the same condition with neutral signaling may indicate a steady space is being transmitted. This gives us a condition called RUNNING OPEN. Under this condition, the teletypewriter appears to be running because the machines is decoding the constant space as the Baudot character blank and the type hammer continually strikes the type box but there is no printing or type box movement across the page.

Q15. What are the two teletypewriter modes of operation?

Q16. Define baud.

Q17. Define bit.

Q18. What are the two types of dc operations used to represent mark and space conditions?

BASIC SYSTEMS

When two ttys are connected by communications wire or cable (over short or long distances), the exchange of information between them is direct. When the teletypewriters are not physically joined, exchange of information is more involved. Direct-current mark and space intervals cannot be sent through the air. The gap between the machines must be bridged by radio using a radio transmitter and receiver. The transmitter produces a radio frequency carrier wave to carry the mark and space intelligence. A **KEYER** is needed to change the dc pulses from the tty into corresponding mark and space modulation for the carrier wave in the transmitter. The radio receiver and a **CONVERTER** are required to change the radio frequency signal back to dc pulses.

Radio Teletypewriter Systems

The Navy uses two basic radio teletypewriter (ratt) systems. These are the **TONE-MODULATED SYSTEM**, referred to as audio-frequency tone shift (afts), and the **CARRIER-FREQUENCY SHIFT SYSTEM**, referred to as radio-frequency-carrier shift (rfcs). The rfc system is also called frequency-shift keying (fsk).

Figure 3-19 shows a modulated carrier wave with audio tone impulses impressed on the radio-frequency carrier wave. These correspond to dc mark and space signals.

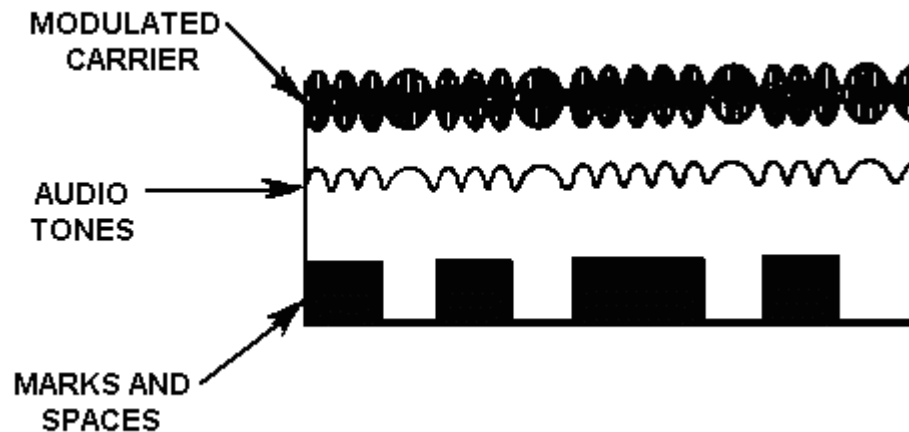

Figure 3-19.—Modulated carrier wave with audio tone for mark and space.

We can best explain the rfc signal by comparing it to the on-off cw signal. Cw signals are essentially a constant frequency with no variations along the frequency axis. Figure 3-20, view A, is an example. The complete intelligence is carried as variations in the signal amplitude. Figure 3-20, view B, shows the same signal as a shift in frequency between the mark and space.

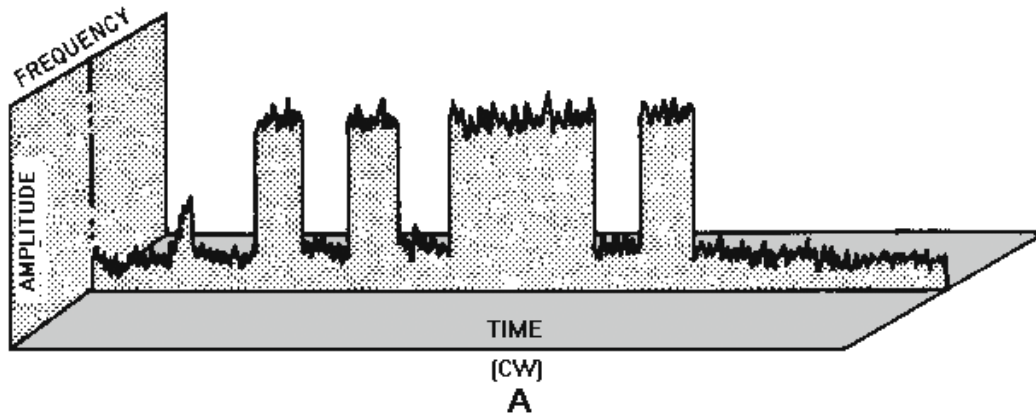

Figure 3-20A.—Cw compared to an rfcs teletypewriter signal.

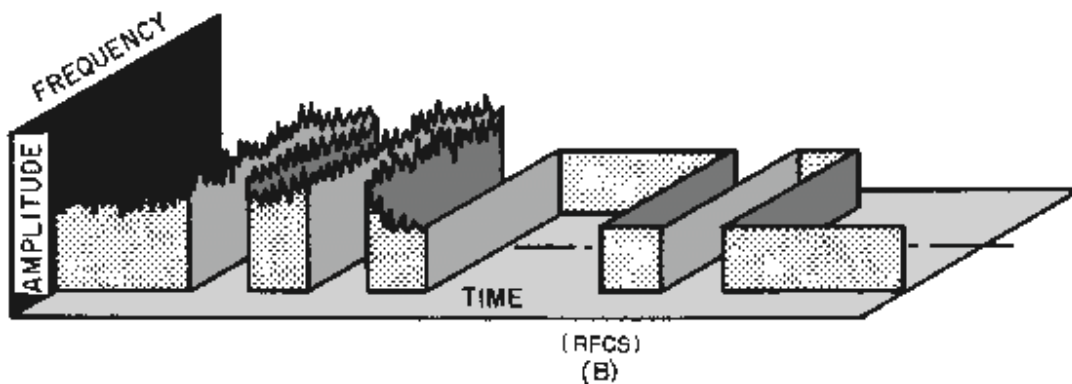

Figure 3-20B.—Cw compared to an rfcs teletypewriter signal.

AUDIO FREQUENCY TONE SHIFT.—Tone-modulated (afts) systems use amplitude modulation to change dc mark and space impulses into audio electrical impulses.

A basic tone-modulated system is shown in figure 3-21. Conversion to audio tones is accomplished by an audio oscillator in the tone converter. Rapid varying of the tone, according to the characters transmitted from the teletypewriter equipment, amplitude modulates the carrier wave in the transmitter. The receiver receives the modulated signal and separates the audio signal from the carrier. This process of separating the modulated signal is known as detection or demodulation.

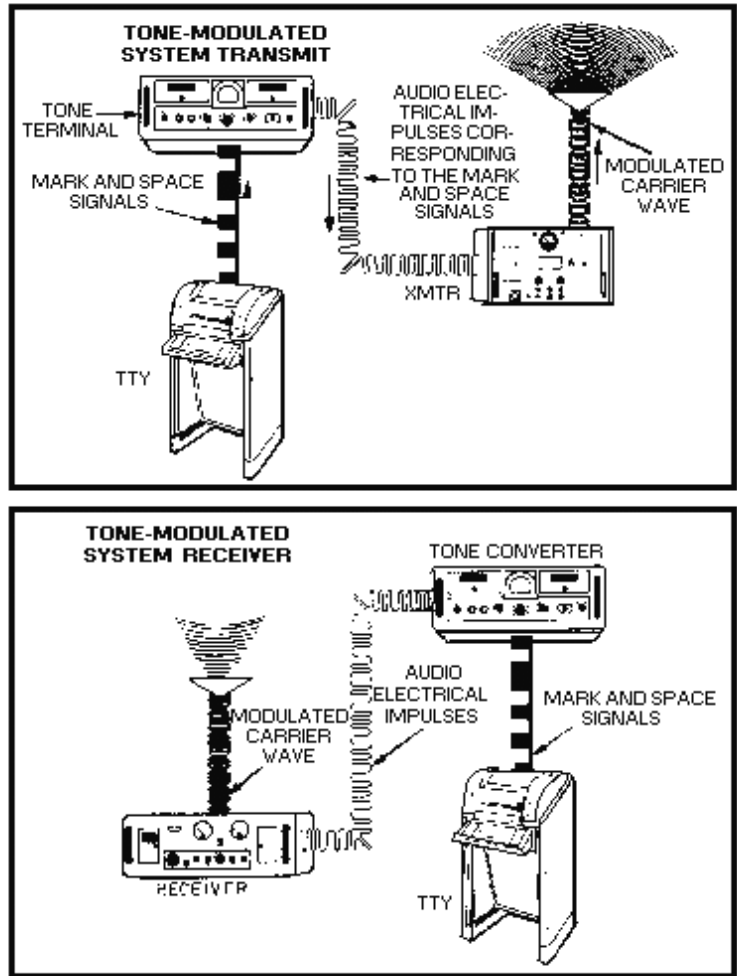

Figure 3-21.—Basic tone modulated (afts) system.

RADIO-FREQUENCY-CARRIER SHIFT.—For frequency-shift (fsk) systems, the transmitter provides a source of radio-frequency excitation. Figure 3-22 illustrates a basic frequency-shift keyed system. In modern systems, the keyer is built into the transmitter. The keyer shifts the signal box below or above the assigned frequency to correspond with the mark or space required to transmit tty characters. Normally the keyer is adjusted for an 850-hertz spread, 425 hertz above and 425 hertz below the assigned frequency. A spacing impulse will be 425 hertz above the operating frequency, and a marking impulse will appear 425 hertz below.

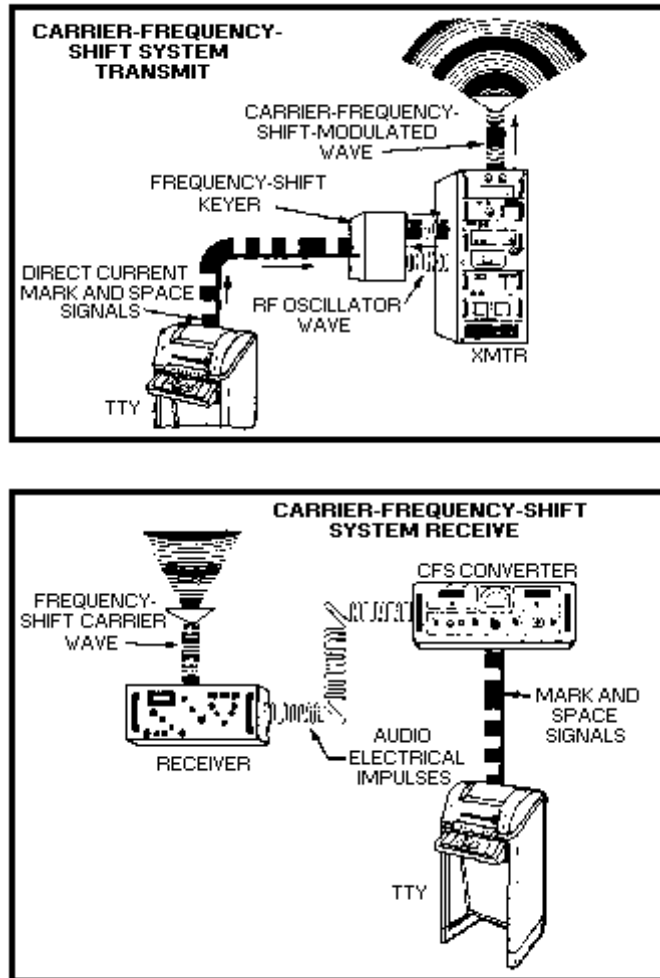

Figure 3-22.—Basic radio-frequency-carrier shift system (rfcs).

In both the tone-modulated system and the carrier-frequency shift system, all tty signals pass through the tty panel that controls the looping current in all the circuits. Looping current is the current supplied by the tty battery. The tty panel integrates the tone-modulated and the carrier-frequency shift systems. It provides every possible interconnection of available tty equipment. With this configuration maximum operational flexibility is achieved with the least amount of circuitry and equipment.

- Q19. What is the function of a keyer?
- Q20. What is the function of a converter?
- Q21. Basically describe an afcs system.
- Q22. Basically describe an rfcs system.

Rfcs Send System

Figure 3-23 shows an rfcs teletypewriter transmit communications system. You should refer to this figure frequently while reading the functional descriptions of the equipment shown.

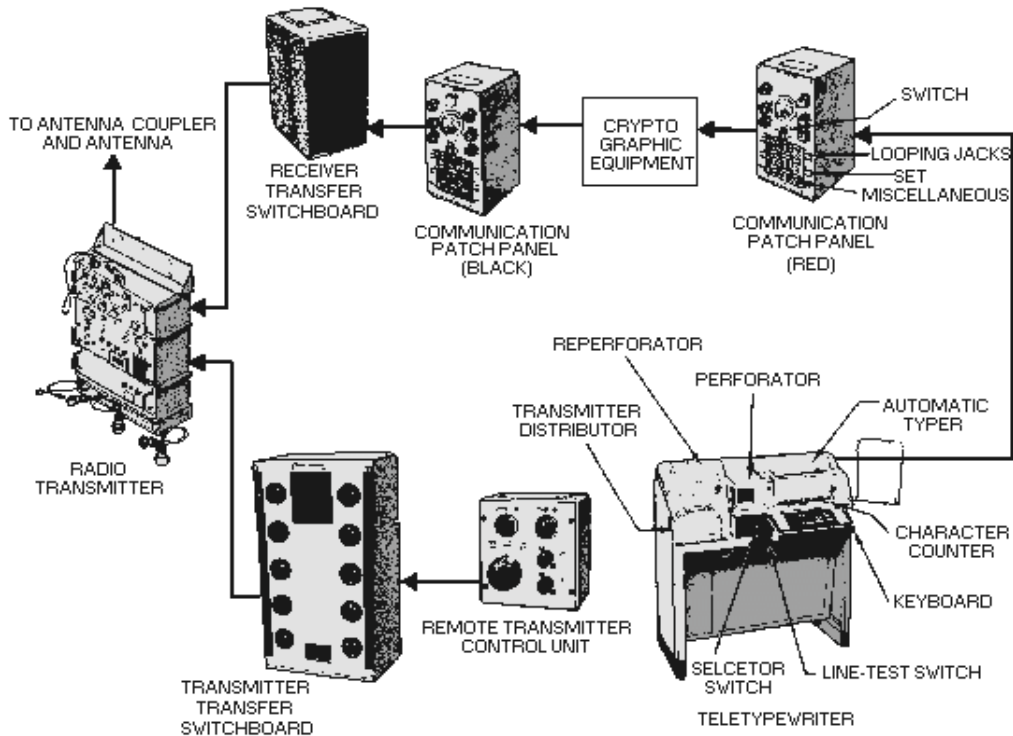

Figure 3-23.—Rfcs transmit (send) system.

TELETYPEWRITER SETS.—Most of the teletypewriter sets used by the Navy belong to one family of tty equipment. This equipment features various weights and sizes, quiet operation, and high operating speeds. They present relatively few maintenance problems. Because of this they are well suited for severe shipboard conditions of roll, vibration, and shock.

These teletypewriters operate at various speeds. Conversion from one speed to another is usually only a matter of changing the gears that are located within the equipment.

Teletypewriters may be send/receive units or receive only units. They may be designed as floor models, table models, or rack and wall-mounted sets. The teletypewriter shown is a send/receive floor model.

The teletypewriter receives messages and prints them on page-size copy paper. In addition, it can receive and record messages on perforated tape. You can use the keyboard or perforated tape to send messages. Page print monitoring is available with both methods. The set shown can prepare perforated and printed tape for separate transmission. It does this with or without simultaneous transmission and page-print monitoring. The combinations of services available are extensive.

The tty set may include a CABINET, KEYBOARD, PAGE PRINTER, TYPING PERFORATOR, TRANSMITTER DISTRIBUTOR, TYPING REPERFORATOR, power distribution panels, and a power supply.

In operation, the components are linked by electrical or mechanical connections. You are given a wide range of possibilities for sending, receiving, or storing tty messages. All equipment components are housed within the cabinet. Transmission signals are initiated through the keyboard (kybd) or through the

transmitter distributor (td). Signals received or local transmissions can be monitored on the page printer. The typing perforator and typing reperforator are devices for preparing tapes on which locally initiated or incoming tty messages can be stored for future transmission through the td.

COMMUNICATION PATCHING PANELS.—Ttys are provided flexibility by jacks that are used to terminate all ttys and associated equipment. The jacks are wired in communications patching panels, usually referred to as tty patch panels. You are able to connect any combination of equipment electrically by means of patch cords.

The plugs on the patch cords are inserted into the jacks at the front of the panel. These plugs have three different parts. They are the tip, ring, and sleeve. The tip carries the intelligence signal while the ring carries the synchronizing (step) or timing signals. The sleeve carries an alarm signal that indicates (both visually and audibly) a problem to the operator. The problem may be equipment failure, loss of loop current, or improper patching. Commonly used combinations of equipment are often wired together within the panel (called normal-through). Individual pieces of equipment are wired on jacks to allow you to use them alone or in combination.

Tty patch panels also furnish a central point for connecting the dc voltage supply into the tty circuits. One source of supply can be used for all circuits passing through a particular panel.

RED and BLACK are used on patch panels to identify whether that panel is used for passing secure or nonsecure information. Red indicates that secure (encrypted) information is being passed through the panel. Black indicates that nonsecure (unencrypted) information is being passed. Patch panels through which secure information is passed are indicated by a red sign on the front that has inch high white block letters that say "RED PATCH PANEL." Panels through which nonsecure information is passed are indicated by two black signs on the front with inch high white block letters. One sign says "BLACK PATCH PANEL" and the other "UNCLAS ONLY."

Each panel contains six channels. Each channel has its own series circuit of looping jacks, set jacks, and a rheostat for adjusting line current. The number of looping and set jacks in each channel varies with the panel model. Each panel includes a meter and rotary selector switch for measuring the line current in any channel. There are six miscellaneous jacks. Any tty equipment not regularly assigned to a channel, may be connected to one of these jacks.

If the desired tty equipment is wired in the same looping channel as the radio adapter used, no patching is required. But, if the desired tty is not wired in the same looping channel as the keyer or converter, it must be patched. For example, let's put a tty on channel 1 and a converter on channel 3. If you want to receive, you must insert one end of the patch cord in the set jack for channel 1 and the other end in either one of the two looping jacks of channel 3.

In any switching operation between the plugs and jacks of a tty panel, the cord plug must be pulled from the looping jack before you remove the other plug from the set (machine) jack. Pulling the plug from the set jack first opens the circuits to the channel, causing all tty messages in the channel to be interrupted.

WARNING

Removing the set (machine) jack before the looping jack exposes a dangerous dc voltage on the exposed plug.

Q23. Most Navy tty sets operate at what speeds?

Q24. A receive tty set provides outputs in what formats?

Q25. What does the color red indicate on a tty patch panel?

CRYPTOGRAPHIC EQUIPMENT.—Cryptographic equipment is used to ENCRYPT and DECRYPT tty messages that require security handling. (Encrypting is the method used to code a transmitted message; decrypting is used to decode a received message.) To code or decode any message, the send and receive cryptographic equipment must be compatible.

REMOTE TRANSMITTER CONTROL UNIT.—The remote transmitter-control unit is mounted close to the kybd and permits remote control of the transmitter (xmtr). It has a transmitter power on-off switch, a power-on indicator lamp, a carrier-on indicator lamp, and a three-position rotary selector switch. For rfcs operation you set the switch to CFS SEND to transmit and to CFS REC to receive. Use the TONE S/R position for both transmitting and receiving afcs signals.

An audio frequency tone-shift system will be discussed later in this chapter.

TRANSMITTER TRANSFER SWITCHBOARD.—The transmitter transfer switchboard is used in this system to connect the remote transmitter control unit to the radio transmitter.

RADIO TRANSMITTER.—The radio transmitter transmits the tty signal. You should be careful when tuning the transmitter for rfcs operation. The carrier frequency setting is critical and must be properly set to ensure a correct output from the transmitter.

Q26. What are the functions of cryptographic equipment?

Rfcs Receive System

Figure 3-24 shows the rfcs receive system used to receive the transmitted signal and translate it back to a usable output. You should look at this figure while studying the units in this section.

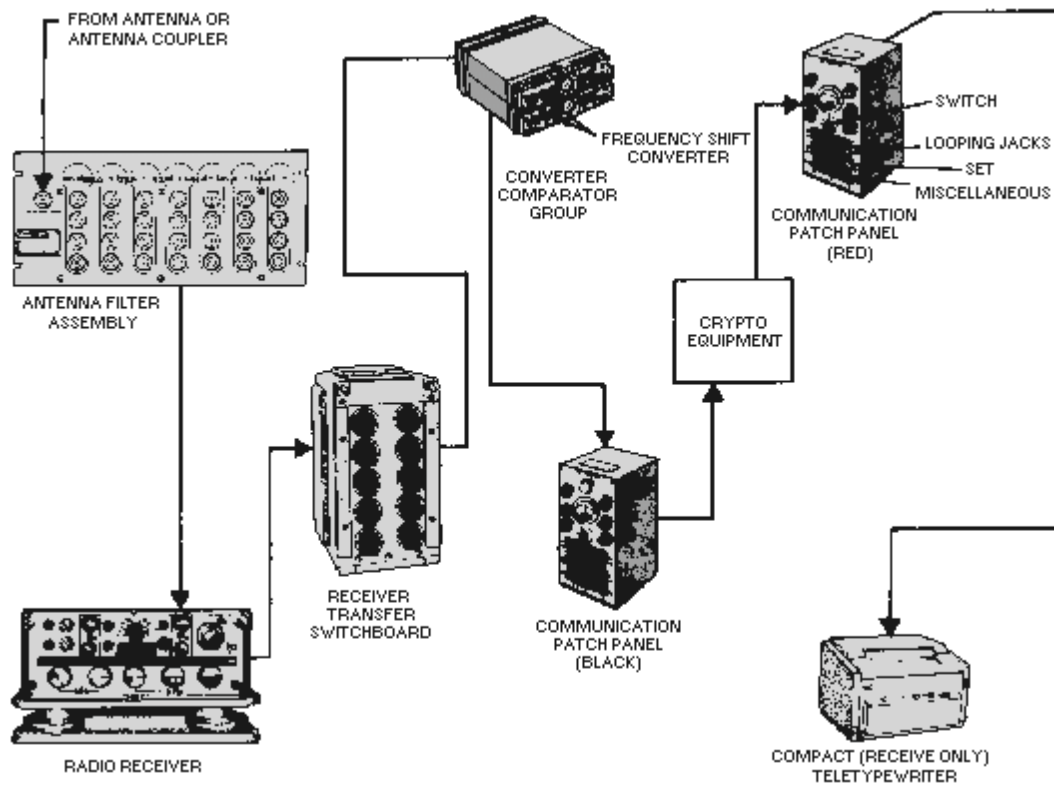

Figure 3-24.—Rfcs receive system.

ANTENNA FILTER ASSEMBLY.—The antenna filter assembly is connected to the antenna and receives the rf signal from the antenna. It filters out any unwanted rf signals and allows the desired band of frequencies to pass.

RADIO RECEIVER.—The radio receiver takes the rf signal passed on by the antenna filter and translates it to an audio signal.

RECEIVER TRANSFER SWITCHBOARD.—The receiver transfer switchboard is used to tie the receiver to any converter unit connected to it. This allows you a wide selection of equipment for connection to the same receiver.

CONVERTER-COMPARATOR GROUP.—The converter-comparator group is used with receivers in either space or frequency diversity operation. When diversity operation is not required, each converter can be used separately with a single receiver.

Each converter has its own COMPARATOR circuitry. This built-in design feature results in a considerable reduction in size from older units. The comparator was located in a separate chassis in the older units. Size has been further reduced through the use of microelectronics.

Figure 3-25 shows the basic method we use to convert a frequency-shift rf signal into a signal that controls the dc loop of a tty. The frequency shifts of the af output from the receiver are converted into dc pulses by the af discriminator. The dc pulses are then fed into the keyer. The keyer opens and closes the dc loop of the tty according to the mark and space characters received.

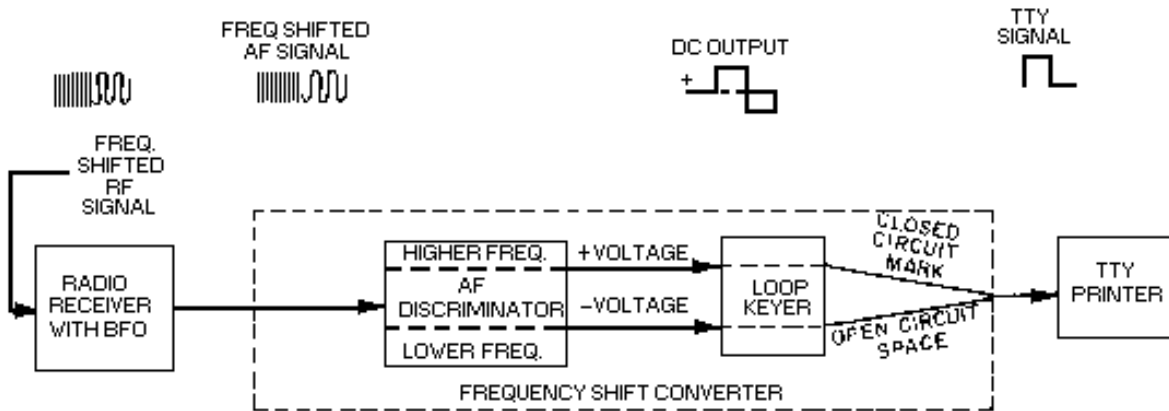

Figure 3-25.—Frequency shift receiving system simplified block diagram.

In diversity operation the comparator section of the converter-comparator group (shown in figure 3-24) compares the strength of the signals from two receivers. Signals from each converter are fed into a comparator circuit that compares the signals. This comparison is displayed on a crt on the front of the equipment. The comparison is in the form of LISSAJOUS PATTERNS. A lissajous pattern is a combined, simultaneous display of the amplitude and phase relationships of two input signals. One signal is applied to the vertical and the other to the horizontal deflection circuits. Lissajous patterns have many applications in electronics. They have operational uses as well as uses in corrective and preventive maintenance. Further coverage on lissajous patterns can be found in NEETS, Module 19, *The Technician's Handbook*. Figure 3-26 shows several typical lissajous monitoring patterns for the converter-comparator group. Once we have a correctly tuned signal, the comparator feeds it to the communication patching panel for patching to the tty. Now let's refer back to figure 3-24 while we discuss the rest of the units in the system.

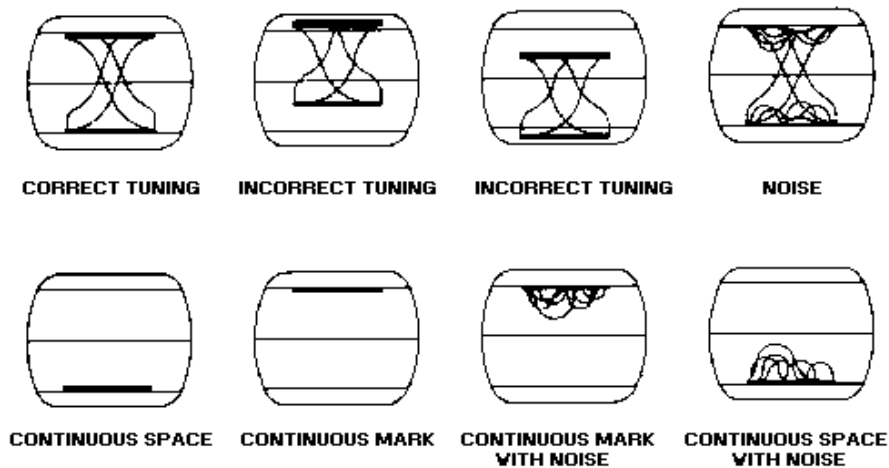

Figure 3-26.—Typical lissajous monitoring patterns.

COMMUNICATION PATCH PANEL.—The communication patch panel serves the same functions on the receive side of the rfc system as it did on the transmit side. It routes the dc signal to the

proper cryptographic equipment. It also routes the decoded teletypewriter signal from the cryptographic equipment to the selected tty.

CRYPTOGRAPHIC EQUIPMENT.—The cryptographic equipment converts the transmitted coded signal to a decoded signal that can be printed out in its original state.

TELETYPEWRITER.—The tty equipment is used to convert the dc signal received from the communication patch panel to a printed copy of the original transmitted message. The tty shown is used only for receive and does not have the ability to transmit.

Q27. What are the functions of a converter-comparator group?

Afts System

Figure 3-27 is a simplified block diagram of a HALF-DUPLEX (send or receive) uhf, audio-frequency-tone shift system. A half-duplex communications circuit permits two-way communications between stations. Communications can be in either direction but not simultaneously. The term half-duplex is qualified by adding send only, receive only, or send or receive. Let's use the block diagram to trace a signal through the system.

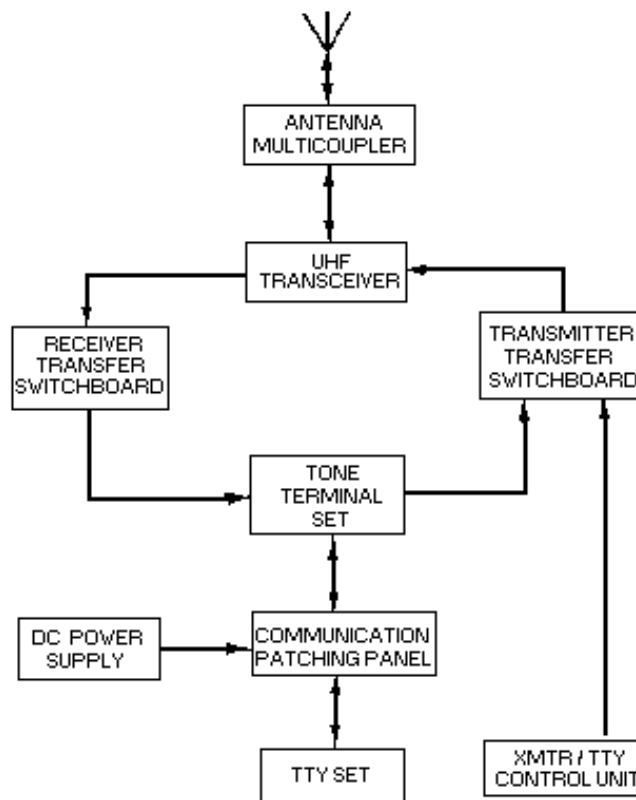

Figure 3-27.—Half-duplex afts teletypewriter system.

SIGNAL FLOW.—On the transmit side, dc signals from the tty set are fed to the communication patching panel. From the panel they are patched to the tone terminal set. The tone terminal set converts

the dc signals into audio tone-shift signals. These signals are then patched to the transmitter section of the transceiver through the transmitter transfer switchboard. The audio tone-shift signals modulate the rf carrier generated by the transmitter (xmtr). The rf tone-modulated signals are then radiated by the antenna.

On the receive side, the rf tone-modulated signals are received at the antenna. You then patch the signal via the multicoupler to the receiver section of the transceiver. Demodulation takes place at this point. The resulting audio tone-shift signals are then patched through the receiver transfer switchboard. The signals now go from the switchboard to the tone terminal set, where they are converted back to dc signals. The dc signals are then patched through the communication patching panel to the tty for printing.

TONE TERMINAL SET.—In tone modulation transmission, the tty pulses are converted into corresponding audio tones. These tones amplitude modulate the rf carrier in the transmitter. Conversion to audio tones is accomplished by an audio oscillator in the tone converter.

An internal relay in the tone converter closes the control line to the transmitter. This keys the transmitter on the air when the operator begins typing a message. The transmitter remains keyed until after the message has been transmitted.

On the receive side, the tone converter accepts the mark and space tones coming in from a receiver and converts them into signals suitable to operate a relay in the converter. The make and break contacts of the relay are connected in the local tty dc loop circuit. This causes the teletypewriter to print in unison with the mark and space signals from the distant tty.

Multiplexing Equipment

The number of communications networks in operation throughout any given area is increasing. As a result, all areas of the rf spectrum have become highly congested.

The maximum number of intelligible transmissions taking place in the radio spectrum is being increased through the use of MULTIPLEXING. Multiplexing is the simultaneous transmission of a number of intelligible signals (messages) in either or both directions using only a single rf carrier. You may use two methods of multiplexing. These are TIME-DIVISION and FREQUENCY-DIVISION.

TIME-DIVISION.—With AM voice and tone communications, we want to transmit and receive for 360 degrees of each sine wave. However, an audio signal may be transmitted and received satisfactorily by periodically sampling the signal. The sampling process yields a received signal like the one shown in figure 3-28. There is no limit to the maximum number of samples that may be made, but you must sample at least twice per cycle of audio to get satisfactory results. In practical systems, 2.4 samples per cycle are usually taken. This concept of sampling forms the basis for time-division multiplex (tdm) operation.

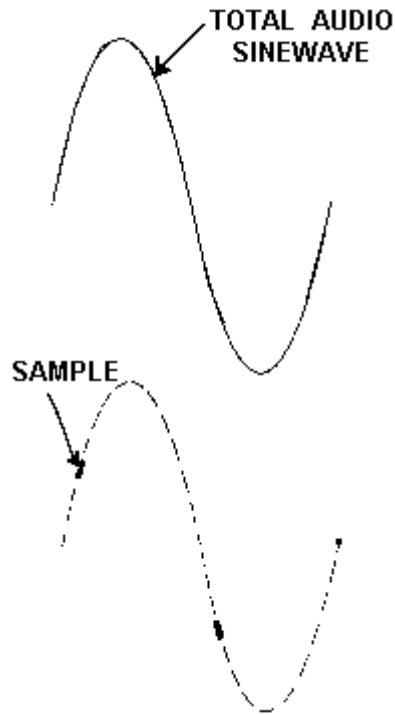

Figure 3-28.—Components of a sine wave.

Figure 3-29, view A, illustrates, the fundamental principle of tdm. Let's look at an example. Assume that a 3,000-hertz tone is applied to each of the six channels in the transmitter. Assume also that the rotating switch turns fast enough to sample, in turn, each of the six channels 2.4 times during each cycle of the 3,000-hertz tone. The speed of rotation of the switch must then be $2.4 \times 3,000$ or 7,200 rotations per second. This is the optimum sampling for a practical system.

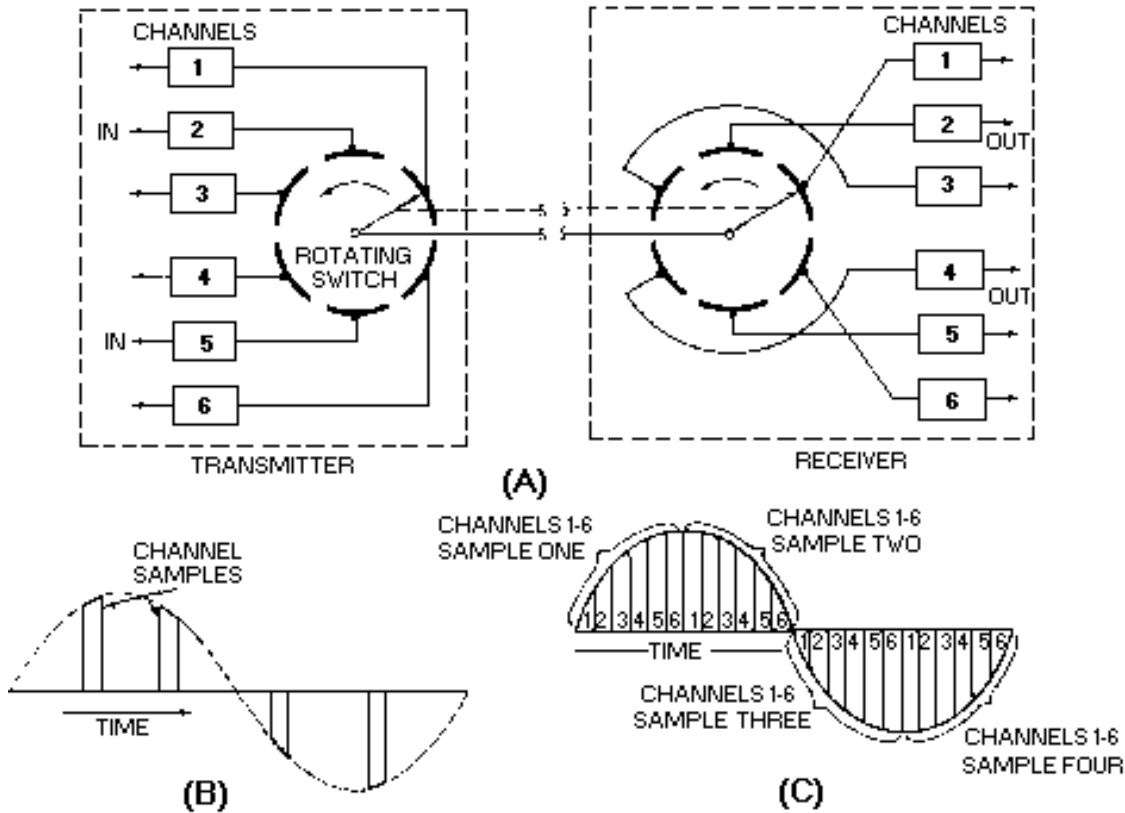

Figure 3-29.—Fundamental principle of time-division multiplexing.

When the transmitter and receiver switches are synchronized, the signals will be fed in the proper sequence to the receiver channels. The samples from transmitter channel one will be fed to receiver channel one. In this way, many channels of audio are combined to form a single output (multiplexed) chain. Time spacing occurs between the components of the separate channels. The chain is transmitted (via wire or radio path) to distant demultiplexing receivers. Each receiving channel functions to select and reconstruct only the information included in the originally transmitted channel.

In most present day applications, electronic switching is used as the sampling component. The main advantage to electronic sampling is the longer life of an electronic switch when compared to an electromechanical switch. We use a mechanical system in our example to make this concept easier for you to see.

Now let's look at figure 3-29, view B, where channel one is shown sampled four times. (This is the output of channel one in our transmitter.) Figure 3-29, view C, shows all six channels being sampled four times during each cycle. (This is the output of the rotating switch in our transmitter.) What you see here is a continuous, time-sharing waveform.

More than six channels (perhaps 24 or more) may be used. As we increase the number of channels, the width of each sample segment must be reduced. The problem with reducing the width of the pulse is that the bandwidth (bw) necessary for transmission is greatly increased. Decreasing the pulse width decreases the minimum required rise time of the sampling pulse and increases the required bandwidth. When you increase the number of channels, you increase the bw. The bw is also affected by the shape of the sampling pulse and the method used to vary the pulse.

Common methods of time-division multiplexing include PULSE AMPLITUDE MODULATION (pam), PULSE WIDTH or PULSE DURATION MODULATION (pwm or pdm), PULSE POSITION MODULATION (ppm), and PULSE CODE MODULATION (pcm). We have been studying an example of pulse amplitude modulation. (These methods of tdm were discussed in NEETS, Module 12, *Modulation Principles*.)

FREQUENCY DIVISION.—Frequency division multiplexing (fdm), unlike tdm, transmits and receives for the full 360 degrees of a sine wave. Fdm used presently by the Navy may be divided into two categories. One category is used for voice communications and the other for tty communications.

The normal voice speaking range is from 100 to 3,500 hertz. During single channel AM voice communications, the audio frequency amplitude modulates a single rf (carrier frequency). However, in voice fdm, each voice frequency modulates a separate frequency lower than the carrier frequency (subcarrier frequency). If these subcarrier frequencies are separated by 3,500 hertz or more, they may be combined in a composite signal. This signal modulates the carrier frequency without causing excessive interference.

In figure 3-30, the output of channel one is the voice frequency range of 100 to 3,500 hertz. The output of channel two is the combination of a different voice frequency with a subcarrier frequency of 4,000 hertz. The output of channel three is another voice frequency. This voice frequency combined with a subcarrier frequency of 8,000 hertz gives you an output frequency range of 8,100 to 11,500 hertz. The overall bw for the composite modulation package shown is 100 to 15,500 hertz. Each separate channel occupies its own band of frequencies. The composite signal is used to modulate the carrier frequency of the transmitter.

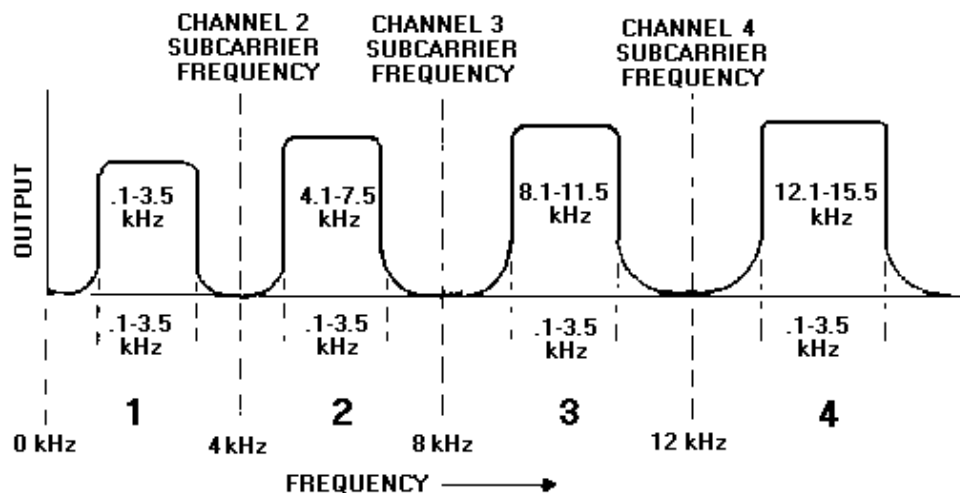

Figure 3-30.—Block diagram of a frequency-division multiplexing system.

Multichannel broadcast and ship/shore terminations use tty fdm. With this system, each channel of the composite tone package of the broadcast is assigned an audio frequency. By multiplexing tty circuits, up to 16 circuits may be carried in any one of the 3,000 hertz multiplexed channels described above. Don't confuse the two types of multiplexing. In the first case, 3,000 hertz audio channels have been combined. In the second case, a number of dc tty circuits are converted to tone keying and combined in a single 3,000-hertz audio channel. Figure 3-31 illustrates a 16-channel, tty-multiplexing system. The output of the dc pulsed circuits is converted to audio keying. Each channel has a separate audio center frequency. Channel frequencies range from 425 hertz for the lowest channel to 2,975 hertz for the highest

channel. A mark in an individual tty loop keys an audio tone 42.5 hertz below the center frequency. A space in the input signal keys an audio tone 42.5 hertz above the center frequency. Let's look at an example. The mark and space frequencies for channel one are calculated as 382.5 hertz and 467.5 hertz, respectively (425 ± 42.5). Combining these keyed tones into a composite signal results in a tone package within a standard 3,000-hertz bandwidth. By occupying no more than 3,000 hertz of the audio spectrum, the output signal is suitable for transmission via radio or landline.

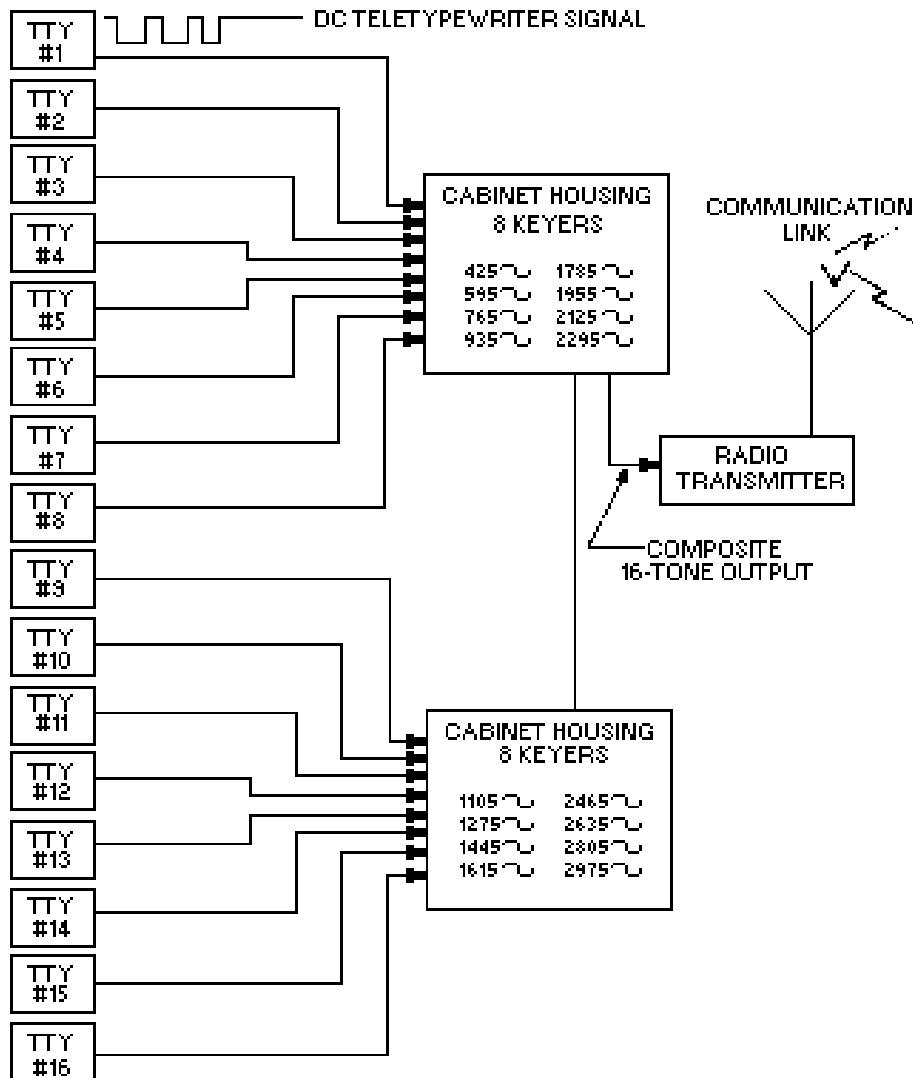

Figure 3-31.—Block diagram of modulator units.

Q28. What is the function of a tone terminal set?

Q29. What are the two types of multiplexing?

Q30. What is the purpose of multiplexing?

Facsimile

FACSIMILE (fax) is a method of transmitting still images over an electrical communications system. The images, called "pictures" or "copy" in fax terminology, may be weather maps, photographs, sketches, typewritten or printed text, or handwriting. Figure 3-32 shows a facsimile transceiver. You must realize that the still image serving as the fax copy or picture cannot be transmitted instantly in its entirety. Three distinct operations are performed. These are (1) scanning, (2) transmitting, and (3) recording or receiving.

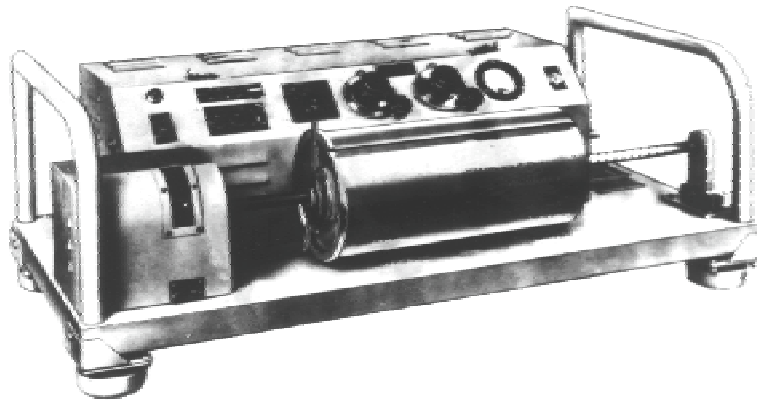

Figure 3-32.—Facsimile transceiver.

Scanning consists of subdividing the picture in an orderly manner into a large number of segments. This process is accomplished in the fax transmitter by a scanning drum and phototube arrangement.

The picture you want to transmit is mounted on a cylindrical scanning drum. This drum rotates at a constant speed and at the same time moves longitudinally along a shaft. Light from an exciter lamp illuminates a small segment of the moving picture and is reflected by the picture through an aperture to a phototube. During picture transmission, the light crosses every segment of the picture as the drum slowly spirals past the fixed lighted area.

The amount of light reflected back to the phototube is a measure of the lightness or darkness of the segment of the picture being scanned. The phototube changes the varying amounts of light into electrical signals. These are used to amplitude modulate the constant frequency output of a local oscillator. The modulated signal is then amplified and sent to the radio circuits.

Signals received by the fax receiver are amplified and actuate a recording mechanism. This recorder makes a permanent recording (segment by segment) on paper. The paper is attached to a receiver drum similar to the one in the fax transmitter. The receiver drum rotates synchronously with the transmitter drum. Synchronization of the receiver and transmitter is done to reduce distortion. Synchronization is obtained by driving both receiver and transmitter drums with synchronous motors operating at the same speed. Drum rotation continues until the original picture is reproduced. The recording mechanism may reproduce the picture photographically by using a modulated light source shining on photographic paper or film. It may also reproduce directly by burning a white protective coating from specially prepared black recording paper.

The receiver drum is FRAMED with respect to the transmitter drum by a series of phasing pulses that are transmitted just before transmission. The pulses operate a clutch mechanism that starts the

scanning drum in the receiver. This ensures proper phasing with respect to the starting position of the scanning drum in the transmitter.

Figure 3-33 is a block diagram of the equipment necessary for radio facsimile operation. View A shows the receiving system. This system consists of a standard radio receiver, a frequency-shift converter, and a facsimile recorder. View B shows two systems for transmitting TIF signals. The upper row of blocks is for carrier-frequency shift transmission. This system consists of a facsimile transceiver, a keyer adapter, a frequency shift keyer and a transmitter capable of fsk emission. The lower row of blocks is for audio-frequency shift transmission and uses a fax transceiver, a radio modulator, and an AM transmitter.

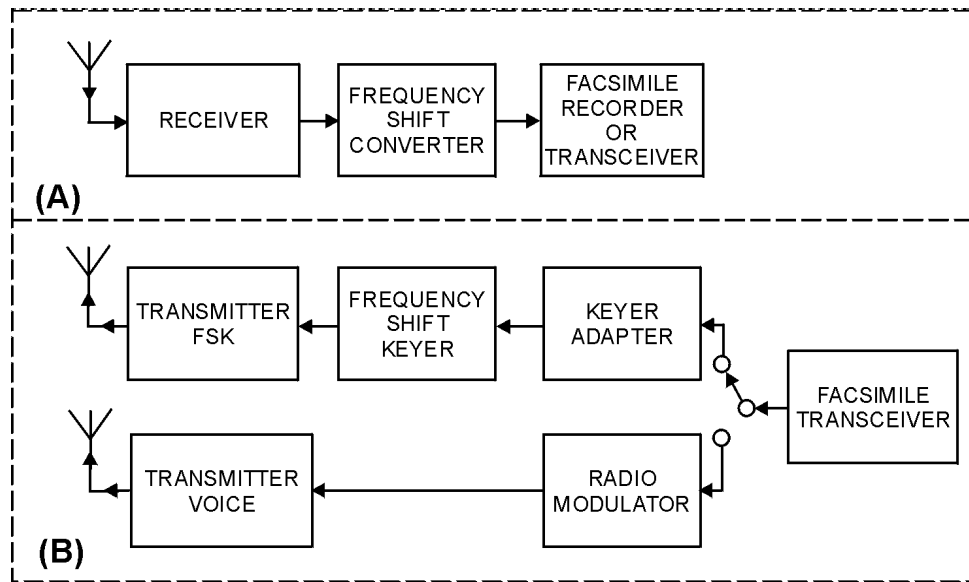

Figure 3-33.—Radio facsimile systems.

SECURITY, QUALITY MONITORING, AND SAFETY

Security, quality monitoring, and safety are important areas that you must be aware of. If the fundamentals are followed, you will see higher quality communications. You will also help meet the communications goals of the Navy. Let's find out what these fundamentals are and what they will do for you.

TEMPEST

Compromising emanations (ce) are, generally referred to as TEMPEST. These signals may be unintentional, data-related, or intelligence-bearing. If intercepted or analyzed, these signals could disclose classified information. TEMPEST problems are associated with material transmitted, received, handled, or otherwise processed by electrical information processing equipment or systems. Any electrical information processing device may cause problems. Even your electric typewriter or a large, complex data processor may emit interceptable compromising emanations. Some countermeasures taken to ensure against TEMPEST problems are listed below:

- Design of equipment in which ce is suppressed
- Approved installation criteria that limits interaction between classified and unclassified signal lines, power lines, grounds, equipment, and systems
- Low level keying and signaling
- Shielded enclosures for equipment installations
- Proper shipboard grounding of equipment, including ground straps

TRANSMISSION SECURITY

Transmission security includes all measures designed to protect transmission from interception, traffic analysis, and imitative deception. Every means of transmission is subject to interception. In radio transmission, it should be assumed that all transmissions are intercepted.

Speed Versus Security

Three fundamental requirements of a military communications system are *reliability*, *security*, and *speed*. Reliability is always first. Security and speed are next in importance and, depending on the stage of an operation, are interchangeable. During the planning phase, security is more important than speed. During the execution phase, speed sometimes passes security in importance.

Radio Transmission Security

When a message is transmitted by radio, the originator may know some of those who are receiving it, but will never know *all* of those who are receiving the message. You must assume that an enemy receives every transmission. Property prepared messages using modern cryptographic systems may prevent an enemy from understanding a message. However, they can still learn a lot. For example, as time for a planned operation approaches, the number of messages transmitted increases. An enemy then knows that something will occur soon, and their forces are alerted. Strict radio silence is the main defense against radio intelligence.

The amount of radio traffic is not the only indicator used by an enemy. Statistical studies of message headings, receipts, acknowledgments, relays, routing instructions, and services are also used by an enemy. Communications experts can often learn much about an opponent from these studies. Direction finders are another aid the enemy can use to determine where messages originate.

Radiotelephone Security

Radiotelephone networks are operated so frequently that many operators tend to be careless. There are too many instances of interception of vhf and uhf transmissions at distances of many thousands of miles. You may have occasion to work on or around this type of equipment. If you are ever required to bring any transmitter on the air for any purpose, you must be familiar with and use all the correct procedures.

Q31. The transmission of still images over an electrical communications system is known as what?

Q32. The term TEMPEST refers to what?

Q33. What are the three fundamental requirements of a military communications system?

Q34. Which of the above requirements is most important?

SHIPBOARD COMMUNICATIONS SYSTEMS QUALITY MONITORING (QMCS)

In recent years the volume of shipboard communications has increased greatly. This expansion has led to the shipboard installation of sophisticated equipment. Factors such as frequency accuracy and dc signal distortion are critical to the operation of communications systems. These systems demand precise initial lineup and monitoring to ensure satisfactory operations are maintained. System degradation is often caused by many small contributing factors. When these factors are added together, the system becomes unusable.

Scheduled Maintenance

When you perform scheduled, logical checks that ensure continuous, optimum performance of shipboard communications systems, you are doing SCHEDULED MAINTENANCE. In many cases this maintenance prevents outages before they occur. Some of the scheduled checks will include the following:

- Transmitter/receiver frequency
- Transmitter power out
- Receiver sensitivity/bandwidth
- Primary power (voltage, current, cycles)

Electromagnetic Interference (emi)

Many complex electronic systems are installed aboard Navy ships. In modern ships, complex systems with higher power and greater sensitivity are being crowded into a restricted and corrosive area. Figure 3-34 is a Spruance class destroyer with its crowded (compact) communications environment. The ability of these systems to perform their individual functions without interference is known as ELECTROMAGNETIC COMPATIBILITY (emc). Emc is concerned with the structure of the ship and its electrical and electronic system. Compact environment is a major limitation to the effectiveness of a total ship system concept.

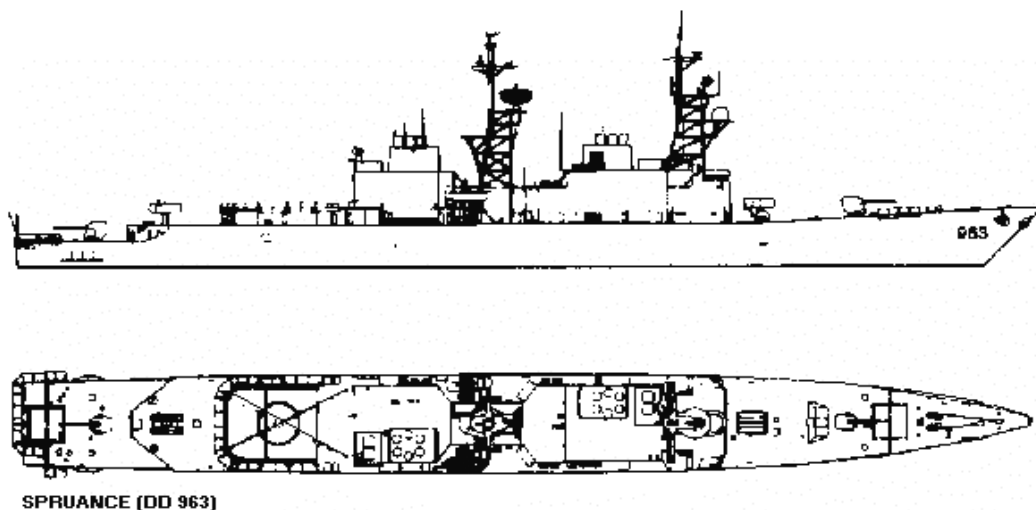

Figure 3-34.—Total ship.

Operation of a total ship system in this unique shipboard environment presents a challenge to all concerned. You must always consider the effects that motion, temperature variations, and exposure to adverse elements will have on the performance of the total ship system. This is particularly true on those system components that are mounted topside.

On board ship, you will find much attention is given to keeping the topside cosmetically and mechanically shipshape. It is equally important to keep it electronically shipshape. Minor mechanical problems, such as loose connections, broken bond straps, or rusty junctions can cause serious communications problems. These sources of electromagnetic radiations reduce receiver performance and are known as ELECTROMAGNETIC INTERFERENCE (emi). Sources of emi can be divided into the following broad categories:

- Functional. Emi can originate from any source designed to generate electromagnetic energy and which may create interference as a normal part of its operation. The interference may be unintentional or caused by other on board or adjacent platform systems. This interference also may be intentional or caused by electronic countermeasures (ECM).
- Incidental. Emi can originate from man-made sources. These are sources not designed specifically to generate electromagnetic energy but which do in fact cause interference. Examples of incidental emi sources include power lines, motors, and switches.
- Natural. Emi can be caused by natural phenomena, such as electrical storms, rain particles, and solar and interstellar radiation. It is recognized by the following audible noises:
 - Intermittent impulses of high intensity that are caused by nearby electrical storms
 - Steady rattling or cracking caused by distant electrical storms
 - Continuous noise of precipitation static caused by electrically charged rain drops
 - A steady hiss at high frequencies caused by interstellar noise
- Hull-generated. Emi can be caused by the interaction of radiated signals with elements of the hull and rigging of a ship. (The functional signals themselves do not cause interference.)

The following are two general methods by which emi is transmitted:

Conduction. Undesired energy from one equipment is coupled to interconnecting cables or components of another equipment. This energy is conducted via the wiring in the shielded enclosure that protects sensitive circuits. You will find proper design, adequate isolation, and shielding of cables and equipment can control this problem.

Radiation. Energy is beamed directly from the transmitting antenna, or source, to the victim receiving antenna. When this interference is picked up by a receiver, you have two solutions. Interfering energy can be eliminated at the source or you can filter, or blank it out at the victim equipment. Filtering is far less desirable. Interference may be on the same frequency as the desired signal and will not be eliminated without affecting the reception of all desired signals.

Most unprotected shipboard receivers are susceptible to emi over a frequency range much wider than their normal bandpass. Off-frequency rejection rarely excludes strong, adjacent-channel signals. These signals enter the receiver and degrade receiver performance by being processed along with the desired, tuned signal. Usually, the presence of emi will be apparent to you. It has a bad effect. Upon the desired signal quality, such as that in CROSS-MODULATION where a spurious response occurs when the carrier

of a desired signal intermodulates with the carrier of an undesired signal. Extremely strong, off-frequency signals may even burn out the sensitive front-end stages of a receiver. Emi also can degrade overall receiver performance in a less noticeable way. It does this by desensitizing the receiver front end. The noise level is raised and effectively lowers the signal to noise ratio and thus the sensitivity. This causes a decrease in desired signal amplification. For these reasons, shipboard receive systems are designed to include protective circuitry between the antenna and receiver to filter out off-frequency signals. This prevents or limits interference, desensitization, or burnout. Depending upon the system, these protective devices may include filters, multicouplers, preselectors, and so forth. These devices can minimize interference caused by inadequate frequency separation or poor physical isolation between transmit and receive antennas.

Q35. What is the purpose of QMCS?

Q36. What is emi?

Q37. What are the two emi transmission methods?

ELECTROMAGNETIC RADIATION

Radio-frequency (rf) transmitting systems with high-power transmitting tubes and high-gain antennas have increased the possibility of injury to personnel working in the vicinity.

An electromagnetic radiation hazard exists when electronic equipment generates a strong enough electromagnetic field to fall in a category listed below:

- Causes harmful or injurious effects to humans and wildlife
- Induces or otherwise couples currents and/or voltages of magnitudes large enough to initiate electroexplosive devices or other sensitive explosive components of weapons systems, ordnance, or other explosive devices
- Creates sparks large enough to ignite flammable mixtures or materials that must be handled in the affected areas

These hazardous situations can be caused by a transmitter or antenna installation. These generate electromagnetic radiation in the vicinity of personnel, ordnance, or fueling operations in excess of established safe levels. Sometimes the existing electromagnetic radiation levels increase to a hazardous level. When personnel, ordnance, or fueling operations are located in an area that can be illuminated by electromagnetic radiation, hazardous situations may occur.

Electromagnetic radiation is hazardous to personnel in two ways. It can cause rf burns; and it can cause biological, thermal, and neurological effects to personnel (RADHAZ). Because of the differences in characteristics and safety precautions required for each of the two types, they will be discussed separately.

An rf burn hazard is a hazardous condition caused by the existence of radio frequency (rf) voltages in places where they are not intended to be. Any ship with high-power hf transmitters is susceptible. Potentially hazardous voltages have been found in many areas. Some of these areas are lifelines, vertical ladders, ASROC launchers, gun mounts, rigging for underway replenishment, and boat davits. Another of these areas is on aircraft tied down on carrier and helicopter flight decks.

Whether or not an induced voltage creates an rf burn hazard depends on whether personnel will come into contact with the object being energized. Generally, only the voltage between an object and the deck is important. The rf burn occurs when a person comes into contact with a source of rf voltage in a

manner that allows rf current to flow through the area of contact. Resistance of the skin to the current flow at the areas of contact causes heat. The effect of the heat on a person at the point of contact ranges from noticeable warmth to a painful burn.

The most useful and widespread technique in the reduction of rf burn hazards is the proper bonding and grounding of all metallic objects in the rf radiation field.

In some cases, the rf burn hazard can be eliminated only through the use of restrictive operating procedures. These procedures govern the simultaneous use of transmitting and cargo equipment. Techniques such as operation of transmitters at reduced power and the prohibition of simultaneous use of certain combinations of antennas, frequencies, and cargo handling equipment are used.

Figure 3-35 shows typical rf radiation hazard warning signs.

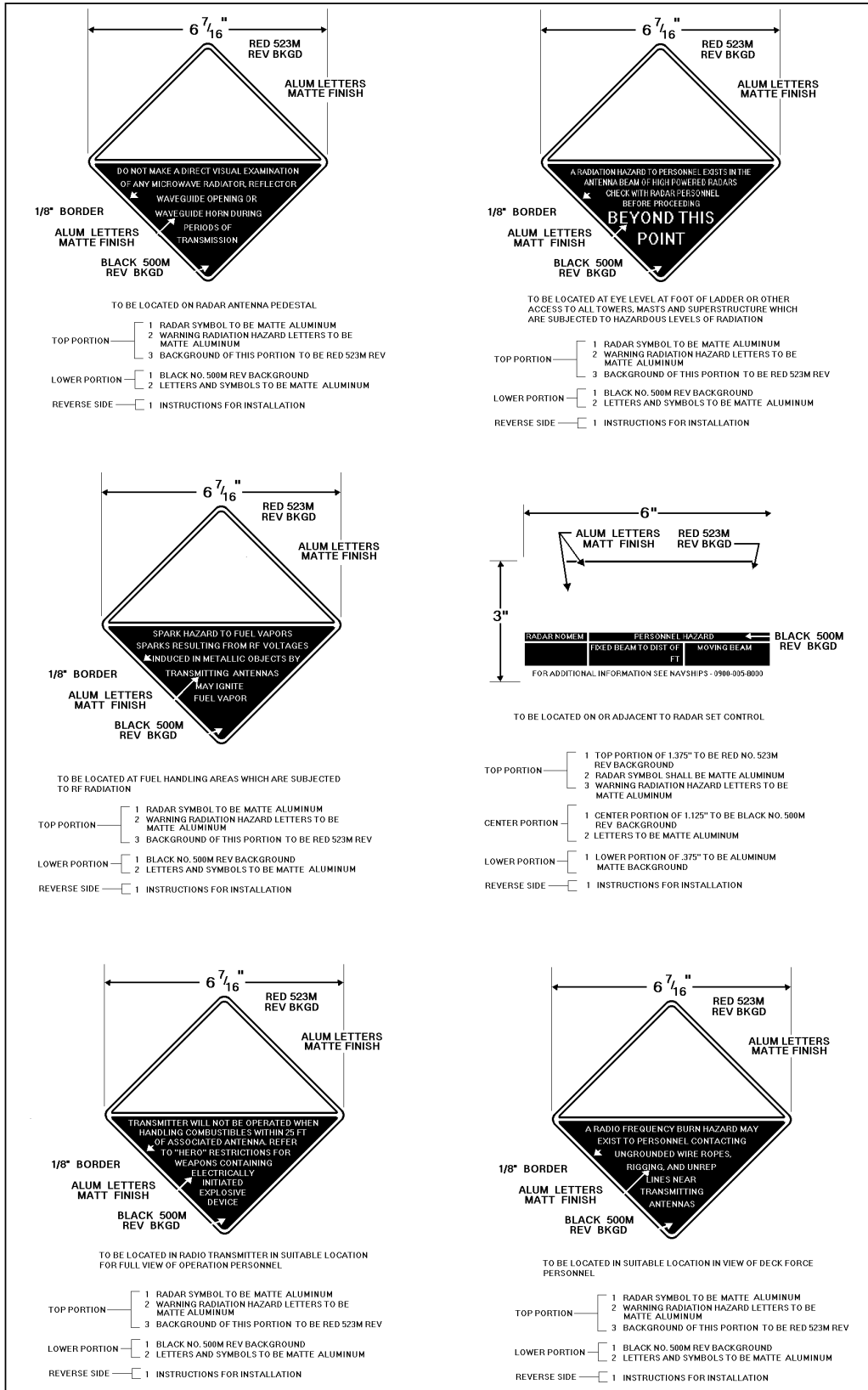

Figure 3-35.—Typical rf radiation hazard warning signs.

Most studies on the subject of radiation hazards (RADHAZ) have emphasized the impact of electromagnetic radiation on man. Man is singled out because of the biological, thermal, and neurological effects that occur in human organs and other biological tissues. Certain organs of the body are considered to be more susceptible than others to the effects of electromagnetic radiation. Presently available information and experience indicate that the eyes and testes are the most vulnerable body organs. The overwhelming danger to date appears to be the hazard from thermal effects, which are a function of intensity of radiation and frequency. This is particularly true in the range of 1 to 3 gigahertz. Thermal effects appear to taper off in severity outside this range.

When the body is irradiated by energy from a point source, the total body surface is usually not exposed. The larger the area exposed and the larger the radiation power density, the higher the body temperature rise and the greater the hazard. Microwave radiation from a radar source will "cook" you internally, just as a microwave oven cooks a chicken.

An injury of great concern is that to the lens of the eye. Exposure of the lens to high-intensity microwaves may cause cataracts. Current medical evidence indicates that a significant temperature elevation of the lens is required for cataract formation. If exposure is limited to 10 milliwatts per centimeter squared, the lens temperature is not elevated to levels at which cataracts occur.

In addition to thermal effects, nonionizing radiation is known to produce nonthermal effects. An association of a biological hazard with the nonthermal effects has not been demonstrated.

A peculiar effect experienced by some personnel is the sensation of sound when they are exposed to pulsed microwave fields. This occurs at levels below stated hazard limits and is not, by itself, considered dangerous.

Q38. Electromagnetic radiation is hazardous to personnel in what two ways?

Q39. What is the most useful and widespread technique to reduce rf burn hazards?

SUMMARY

Now that you have completed this chapter, a short review of what you have learned is in order. The following summary will refresh your memory of basic systems equipment, its principles, terms, and typical circuitry required for you to understand this concept.

A **RADIO SET CONTROL UNIT** is used to remotely control certain transmitter and receiver functions.

TRANSMITTER TRANSFER SWITCHBOARDS selectively transfer remote control station functions and signals to transmitters.

RECEIVER TRANSFER SWITCHBOARDS transfer receiver audio outputs to remote control station audio circuits.

A **TRANSMITTER** generates an rf carrier, modulates it with intelligence, amplifies it, and applies it to an antenna.

An **ANTENNA COUPLER** is a device used for impedance matching between an antenna and a transmitter or receiver.

A **RECEIVER** receives electromagnetic energy (rf) and may convert it to a visible or audible form.

MULTICOUPLERS patch several receivers or transmitters to one antenna. They also filter out harmonics and spurious responses, and provide impedance matching.

MARKING is when a circuit is closed and current flows in teletypewriter operation.

SPACING is when a circuit is open and no current flows in teletypewriter operation.

INTELLIGENCE is any signal that conveys information (voice, teletypewriter, facsimile).

A **START** unit is the first unit of a teletypewriter signal. It is always a space.

A **STOP** unit is the last unit of a teletypewriter signal. It is always a mark.

A **TRANSITION** is the time it takes to shift from a mark to a space condition or from a space to a mark condition.

A **CODE** in teletypewriter operation is a combination of mark and space conditions representing symbols, figures, or letters.

NONSYNCHRONOUS teletypewriter operation is when both transmitter and receiver do not operate continuously.

SYNCHRONOUS teletypewriter operation is when both transmitter and receiver operate continuously.

WORDS-PER-MINUTE is an approximate rate of speed. It means the number of five letter words with a space between them that can be transmitted or received in a one-minute period.

BAUD is a measurement of speed based on the number of code elements or units per second.

BITS-PER-SECOND is an acronym of the words binary digit. One bit is equal to one signal unit or element.

NEUTRAL teletypewriter operation is where current flow represents a mark and no flow represents a space.

POLAR teletypewriter operation is where current flow of one polarity represents a mark and current of the opposite polarity is a space.

RUNNING OPEN is the teletypewriter condition where the type hammer constantly strikes the type box but does not print or move across the page.

A **KEYER** is a device that changes dc pulses to mark and space modulation for teletypewriter transmissions.

A **CONVERTER** changes an audio signal back to dc pulses during teletypewriter reception.

AUDIO FREQUENCY TONE SHIFT systems use amplitude modulation to change dc mark and space impulses into audio impulses.

RADIO FREQUENCY CARRIER SHIFT systems use a keyer to shift a radio frequency signal above or below an assigned frequency. These shifts correspond to marks and spaces.

A **TELETYPEWRITER** is a machine that can transmit and or receive letters, numbers, or symbols. It may have a keyboard similar to a typewriter.

A **PERFORATOR** is a device that stores a teletypewriter message on a paper tape by punching Baudot coded messages into it.

TRANSMITTER DISTRIBUTOR is a device that reads Baudot code from paper tape and allows a message to be sent or a message to be printed on a page printer.

A **REPERFORATOR** stores an incoming tty signal on paper tape.

A **PAGE PRINTER** prints teletypewriter characters one at a time in a full-page format. This is usually a high-speed printer.

RED is the reference color of equipment that passes classified information. It normally refers to patch panels.

BLACK is the reference color of equipment that passes unclassified information. It normally refers to patch panels.

A **PATCH PANEL** is used to tie a receiver or transmitter to its associated equipment.

A **COMPARATOR** compares incoming signals and selects the strongest to be fed to a teletypewriter through a patch panel. This is used in diversity operation

A **LISSAJOUS PATTERN** is a combined, simultaneous display of the amplitude and phase relationships of two input signals on a crt.

A **TONE-TERMINAL** set converts tty dc pulses into audio tones for modulation of a transmitter in audio-frequency tone shift transmissions.

MULTIPLEXING is the process of transmitting a number of intelligence signals simultaneously over a single rf carrier.

TIME-DIVISION multiplexing is the process that periodically samples several intelligence signals. This can be a received signal or one to be transmitted.

FREQUENCY-DIVISION multiplexing transmits and receives the full 360 degrees of each sine wave.

FACSIMILE is the method for transmitting and receiving still images. These images can be maps, photographs, and handwritten or printed text.

SCANNING is the process of subdividing a picture in an orderly manner into segments. This is used in facsimile transmission.

FRAMING is the process of synchronizing a facsimile receiver to a transmitter. This allows proper picture reproduction.

TEMPEST is a term normally used to describe compromising emanations. These emanations are unintentionally radiated signals that could disclose classified information.

ELECTROMAGNETIC INTERFERENCE is a term used to describe the degradation of a receiver or system by externally produced rf energy.

ANSWERS TO QUESTIONS Q1. THROUGH Q39.

- A1. To convert energy electrical/acoustic to acoustic/electrical and to key/unkey a transmitter. Also it mutes a receiver when transmitting.*
- A2. Transferring remote control functions and signals to transmitters.*
- A3. Transfers receiver audio outputs to remote control stations.*
- A4. 800 watts.*
- A5. Automatic, semiautomatic, and manual.*
- A6. It matches the impedance of an antenna to that of a transmission line at any desired frequency.*
- A7. To aid in heat transfer and prevent corona and arcing.*
- A8. Lsb, usb, isb, AM, cw, fsk.*
- A9. Digital.*
- A10. To connect an antenna/transmission line to a receiver/transmitter.*
- A11. Patching and filtering and permits the multiple use of receivers and/or transmitters on a single antenna.*
- A12. Space and mark.*
- A13. Intelligence (5), start (1), stop (1).*
- A14. Shift signals.*
- A15. Synchronous and nonsynchronous.*
- A16. A unit of modulation rate.*
- A17. Binary digit.*
- A18. Neutral and polar.*
- A19. Converts dc to corresponding mark and space modulation.*
- A20. Converts the audio signal to dc pulses.*
- A21. Uses AM to change dc to audio.*
- A22. A keyer provides rf excitation, which can be shifted above or below the assigned frequency.*
- A23. 60, 75, or 100 wpm.*
- A24. Page-size copy paper and perforated tape.*
- A25. It handles classified information.*
- A26. To code or decode messages.*

- A27. *The comparator compares the signal strengths from the receivers and the converter converts the frequency-shift rf signal into a tty set dc loop control signal.*
- A28. *It converts dc to audio or vice versa.*
- A29. *Time-division and frequency-division.*
- A30. *It allows simultaneous transmission of multiple signals on a single transmission path.*
- A31. *Facsimile.*
- A32. *Compromising emanations.*
- A33. *Reliability, security, and speed.*
- A34. *Reliability.*
- A35. *To ensure continuous, optimum performance of communications systems.*
- A36. *Electromagnetic interference.*
- A37. *Conduction and radiation.*
- A38. *Rf burns and biological, thermal, and neurological effects.*
- A39. *Proper bonding and grounding.*

CHAPTER 4

INTRODUCTION TO SATELLITE COMMUNICATIONS

LEARNING OBJECTIVES

Upon completion of this chapter you will be able to:

1. Describe the basic operation of the two types of satellites.
2. Describe the basic components of an operational satellite system.
3. Describe the function of earth terminal equipment.
4. Describe the basic signal flow of a typical shipboard receive-only system.
5. Describe the basic signal flow of a typical shipboard transceiver system.
6. Describe the advantages of satellite communications in terms of capacity, reliability, vulnerability, and flexibility.
7. Describe the limitations of satellites in terms of power, receiver sensitivity, and availability.

HISTORY OF SATELLITE COMMUNICATIONS

The first artificial satellite was placed in orbit by the Russians in 1957. That satellite, called *Sputnik*, signaled the beginning of an era.

The United States, who was behind the Russians, made an all-out effort to catch up, and launched *Score* in 1958. That was the first satellite with the primary purpose of communications.

The first regular satellite communications service was used by the Navy in 1960. The moon was used to bounce teletypewriter signals between Hawaii and Washington, D.C. During the early 1960s, the Navy used the moon as a medium for passing messages between ships at sea and shore stations. This method of communications proved reliable when other methods failed.

Military satellite communications technology was at a low level until 1965. At that time high quality voice transmissions were conducted between a satellite and two earth stations. That was the stepping stone to the Initial Defense Communications Satellite Program (IDCSP), which will be covered later in this chapter.

Experience with satellite communications has demonstrated that satellite systems can satisfy many military requirements. They are reliable, survivable, secure, and a cost effective method of telecommunications. You can easily see that satellites are the ideal, if not often the only, solution to problems of communicating with highly mobile forces. Satellites, if properly used, provide much needed options to large, fixed-ground installations.

For the past fifty years, the Navy has used high-frequency (hf) transmissions as the principal method of sending messages. In the 1970s, the hf spectrum was overcrowded and "free" frequencies were at a

premium. Hf jamming and electronic countermeasures (ECM) techniques became highly sophisticated during that period. As a result the need for new and advanced long-range transmission methods became apparent.

Communications via satellite is a natural outgrowth of modern technology and of the continuing demand for greater capacity and higher quality in communications.

In the past, the various military branches have had the resources to support their communications needs. Predicted usage indicates that large-scale improvements will have to be made to satisfy future needs of the Department of Defense. These needs will require greater capacity for long-haul communications to previously inaccessible areas. Satellite communications has the most promise for satisfying these future requirements.

DEFENSE COMMUNICATIONS SATELLITE PROGRAM (DCSP)

The Defense Communications Satellite Program (DCSP) was initiated by the Secretary of Defense in 1962. Phase I of the program was given the title Initial Defense Communications Satellite Program (IDCSP). The first satellite launch occurred in June 1966 when seven experimental satellites were placed into orbit. The final launch of this program consisted of eight satellites and occurred in June 1968.

DEFENSE SATELLITE COMMUNICATIONS SYSTEM (DSCS) PHASE II

The Phase II Defense Satellite Communications System (DSCP Phase II) has changed from an all-analog communications system to an all-digital communications system. The performance capability provided by the Phase II DSCS is limited by equipment availability. Extensive digital traffic capability has become common. You can credit this to the availability of digital modems (modulator/demodulator) and broadband equipment. Overall performance of the Phase II DSCS is a great improvement over the capabilities provided by Phase I DSCS. The Phase II satellites provide a great increase in effective radiated power and rf bandwidths. You will find these satellite configurations use wide coverage and narrow beam antennas. They provide an extensive range of communications services and capabilities. (This will be further discussed later, in this chapter.)

FUNDAMENTAL SATELLITE COMMUNICATIONS SYSTEM

A satellite communications system uses satellites to relay radio transmissions between earth terminals. The two types of communications satellites you will study are ACTIVE and PASSIVE. A passive satellite only reflects received radio signals back to earth. An active satellite acts as a REPEATER; it amplifies signals received and then retransmits them back to earth. This increases signal strength at the receiving terminal to a higher level than would be available from a passive satellite.

A typical operational link involves an active satellite and two or more earth terminals. One station transmits to the satellite on a frequency called the UP-LINK frequency. The satellite then amplifies the signal, converts it to the DOWN-LINK frequency, and transmits it back to earth. The signal is next picked up by the receiving terminal. Figure 4-1 shows a satellite handling several combinations of links simultaneously.

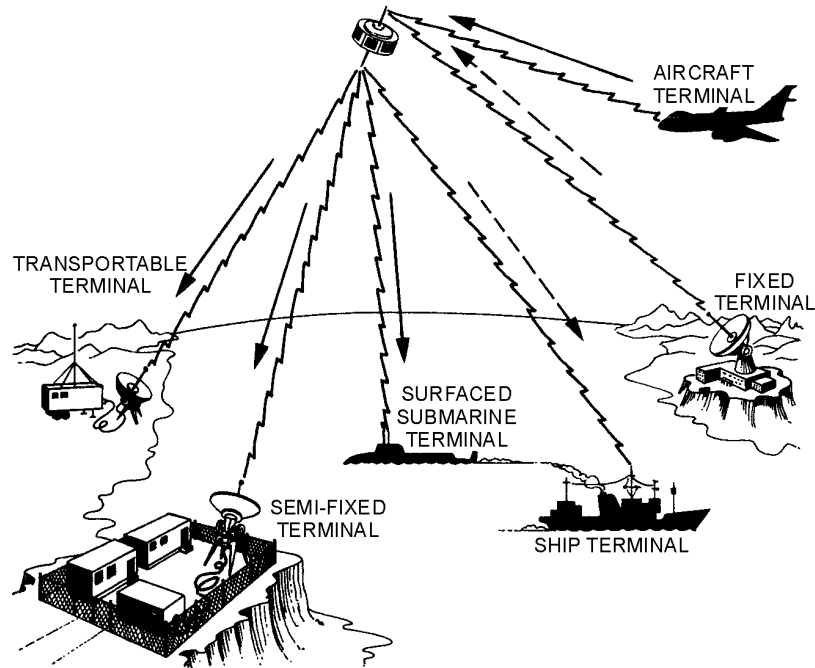

Figure 4-1.—Satellite communications system.

DESCRIPTION OF COMMUNICATIONS SATELLITE SYSTEM

The basic design of a satellite communications system depends to a great degree upon the characteristics of the orbit of the satellite. In general terms, an orbit is either elliptical or circular in shape. A special type of orbit is a **SYNCHRONOUS ORBIT**. In this type you will find the period (time required for one revolution) of the orbit the same as that of the earth. An orbit that is not synchronous is called **ASYNCHRONOUS**. A period of orbit that approaches that of the earth is called **NEAR SYNCHRONOUS** (subsynchronous). Orbits are discussed in more detail later in this chapter.

In addition to the fundamental components shown in figure 4-1, the design of the overall system determines the complexity of the various components and the manner in which the system operates. Current satellites are capable of handling many teletypewriter (tty) and voice circuits at the same time.

Orbit Descriptions

Orbits generally are described according to the physical shape of the orbit and the angle of inclination of the plane of the orbit. These terms are discussed in the following paragraphs:

PHYSICAL SHAPE.—All satellites orbit the earth in elliptical orbits. (A circle is a special case of an ellipse.) The shape of the orbit is determined by the initial launch parameters and the later deployment techniques used.

PERIGEE and **APOGEE** are two, of the three parameters used to describe orbital data of a satellite. These are shown on figure 4-2. Perigee is the point in the orbit nearest to the center of the earth. Apogee is the point in the orbit the greatest distance from the center of the earth. Both distances are expressed in nautical miles.

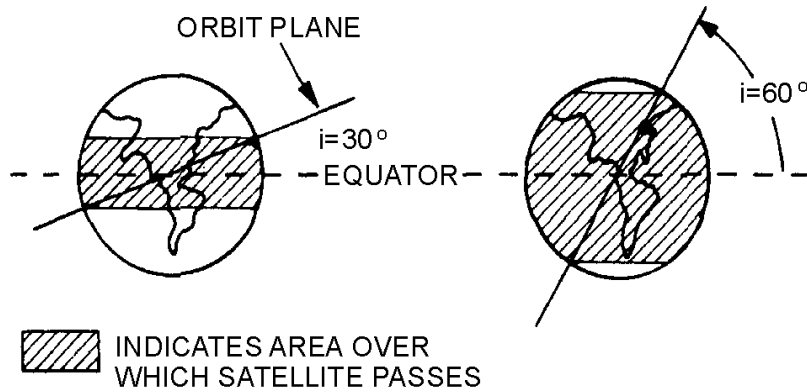

Figure 4-2.—Elliptical satellite orbit.

ANGLE OF INCLINATION.—The ANGLE OF INCLINATION (angle between the equatorial plane of the earth and the orbital plane of the satellite) is the third parameter used to describe the orbit data of a satellite. Figure 4-3 depicts the angle of inclination between the equatorial plane and the orbital plane. Most satellites orbit the earth in orbital planes that do not coincide with the equatorial plane of the earth. A satellite orbiting in any plane not identical with the equatorial plane is in an INCLINED ORBIT.

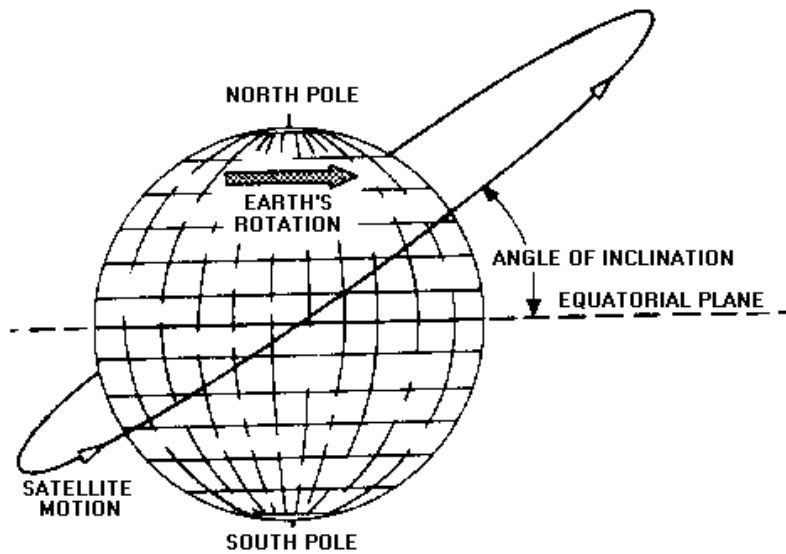

Figure 4-3.—Inclined satellite orbit.

The inclination of the orbit determines the area covered by the path of the satellite. As shown in figure 4-4, the greater the inclination, the greater the amount of surface area covered by the satellite.

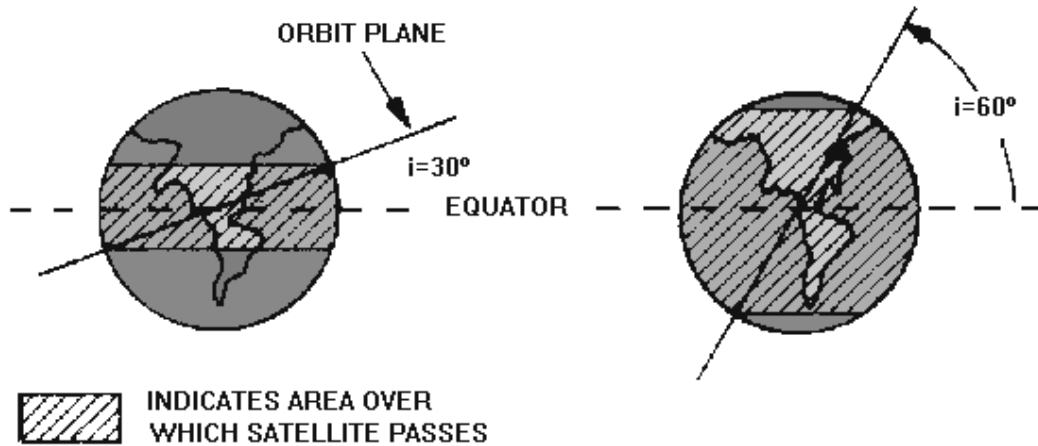

Figure 4-4.—Effect of orbit plane inclination on satellite coverage.

SPECIAL TYPES OF INCLINED ORBITS.—A satellite orbiting in a plane that coincides with the equatorial plane of the earth is in an EQUATORIAL ORBIT. A satellite orbiting in an inclined orbit with an angle of inclination of 90 degrees or near 90 degrees is in a POLAR ORBIT.

SPECIAL TYPES OF CIRCULAR ORBITS.—We stated previously that a circular orbit is a special type of elliptical orbit. You should realize a circular orbit is one in which the major and minor axis distances are equal or approximately equal. Mean height above earth, instead of perigee and apogee, is used in describing a circular orbit. While we are discussing circular orbits, you should look at some of the terms mentioned earlier in this chapter. A satellite in a circular orbit at a height of approximately 19,300 nautical miles above the earth is in a synchronous orbit. At this altitude the period of rotation of the satellite is 24 hours, the same as the rotation period of the earth. In other words, the orbit of the satellite is in sync with the rotational motion of the earth. Although inclined and polar synchronous orbits are possible, the term synchronous usually refers to a synchronous equatorial orbit. In this type of orbit, satellites appear to hover motionlessly in the sky. Figure 4-5 shows how one of these satellites can provide coverage to almost half the surface of the earth.

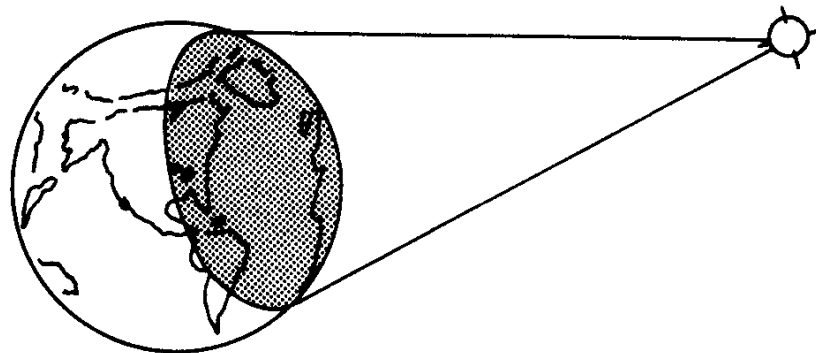

Figure 4-5.—Illumination from a synchronous satellite.

Three of these satellites can provide coverage over most of the earth (except for the extreme north and south polar regions). A polar projection of the global coverage of a three-satellite system is shown in figure 4-6.

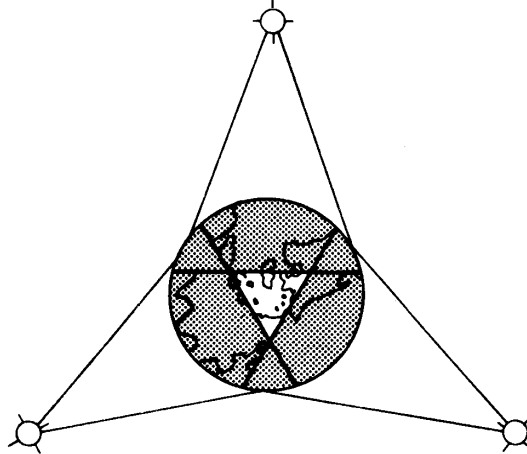

Figure 4-6.—Worldwide synchronous satellite system viewed from above the North Pole.

A satellite in a circular orbit at other than 19,300 nautical miles above the earth is in a near-synchronous orbit. If the orbit is lower than 19,300 nautical miles, the period of orbit of the satellite is less than the period of orbit of the earth. The satellite then appears to be moving slowly around the earth from west to east. (This type of orbit is also called subsynchronous.) If the orbit is higher than 19,300 nautical miles, the period of orbit of the satellite is greater than the period of orbit of the earth. The satellite then appears to be moving slowly around the earth from east to west. Although inclined and polar near-synchronous orbits are possible, near synchronous implies an equatorial orbit.

A satellite in a circular orbit from approximately 2,000 miles to 12,000 miles above the earth is considered to be in a **MEDIUM ALTITUDE ORBIT**. The period of a medium altitude satellite is considerably less than that of the earth. When you look at this altitude satellite, it appears to move rather quickly across the sky from west to east.

- Q1. What are the two types of communications satellites?*
- Q2. A typical satellite communications operational link consists of a satellite and what two other components?*
- Q3. A satellite in a synchronous orbit can cover how much of the surface of the earth?*
- Q4. What areas of the earth are not normally covered by satellites?*

SATELLITE CHARACTERISTICS

Early communications satellites were limited in size to the diameter of the final stage of the rocket that was used for launching. Weight was determined by the thrust of the rocket motors and the maximum weight the rocket could lift into orbit.

As early as June 1960, two satellites were successfully placed in orbit by the same launch vehicle. With the development of multilaunch capability, added flexibility became available. We then had choices as to the size, weight, and number of satellites to be included in each launch.

Using our multilaunch capabilities, the Defense Satellite Communications System (DSCS) has placed larger and heavier satellites in synchronous equatorial orbits. Figure 4-7 is a drawing of a DSCS satellite. It shows each pair of transmit and receive dish antennas. As you can see, a large area of the earth can be covered using only one satellite.

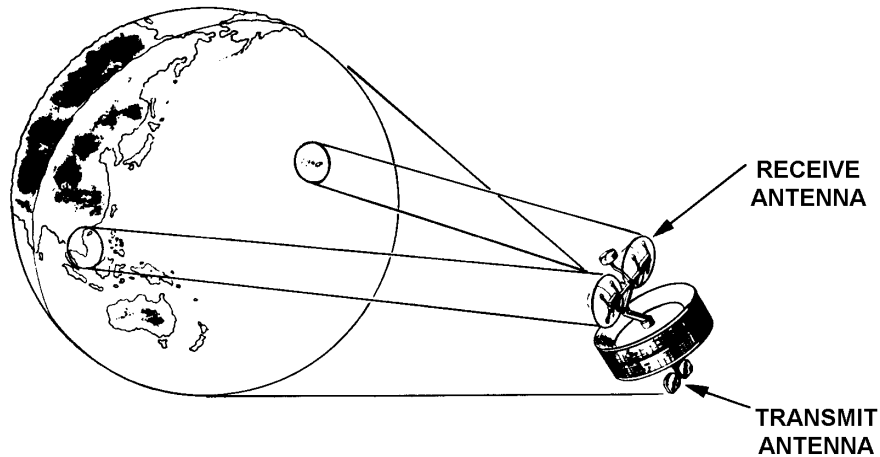

Figure 4-7.—DSCS satellite.

Satellite Power Sources

Early communications satellites were severely limited by the lack of suitable power sources. This severely limited the output power of the satellite transmitter. The only source of power available within early weight restrictions was a very inefficient panel of solar cells without battery backup. A major disadvantage of this type of power source is that the satellite has no power when it is in ECLIPSE (not in view of the sun). For continuous communications, this outage is unacceptable.

A combination of solar cells and storage batteries is a better prime power source. This is a practical choice, even though the result is far from an ideal power source. About ten percent of the energy of the sunlight that strikes the solar cells is converted to electrical power. This low rate is sometimes decreased even further. You find this when the solar cells are bombarded by high-energy particles that are sometimes found in space.

Early satellites had over 8,500 solar cells mounted on the surface of the satellite, which supplied about 42 watts of power. No battery backup was provided in these satellites.

Newer communications satellites have about 32,000 solar cells mounted on the surface of the satellite, and they supply about 520 watts. A nickel cadmium battery is used for backup power during eclipses.

Nuclear power sources have been used in space for special purposes, but their use stops there. Technology has not progressed sufficiently for nuclear power sources to be used as a power source.

Satellite Orientation

Satellite orientation in space is important for continuous solar cell and antenna orientation. Since the primary source of power in most satellites is from solar cells, a maximum number of the solar cells must be exposed to the sun at all times. The satellite antenna must also be pointed at the appropriate earth terminals. Our communications satellites use what is termed spin stabilization to meet these important requirements.

Spin stabilization operates on the principle that direction of the spin axis of a rotating body tends to remain fixed in space. An example of spin stabilization is the effect of the rotation of the earth in keeping its axis fixed in space. A satellite that has a spin axis parallel to the axis of the earth will maintain this position since both axes are fixed in space. Figure 4-8 illustrates the use of this principle. It depicts an equatorial orbit satellite used to keep a doughnut-shaped antenna pattern pointing toward the earth.

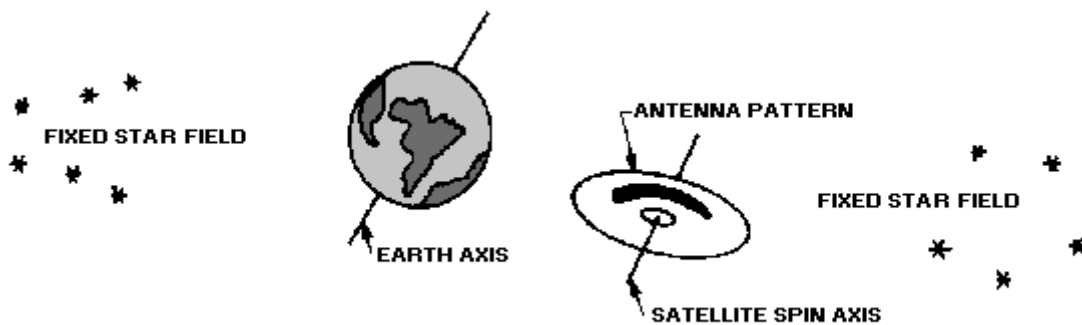

Figure 4-8.—Spin-stabilized satellite antenna pattern.

Once the system is in motion, spin stabilization requires virtually no additional energy. A spin-stabilized satellite is usually constructed like a flywheel. Its heavier equipment is mounted in the same plane and as close to the outside surface as possible.

After reaching its orbit, the radial jets are pulsed to start the satellite spinning. The satellite spin axis is orientated to the axis of the earth by means of small axial jets. Velocity jets are used to place the satellite in orbit position and provide velocity correction. Figure 4-9 is an example of spin stabilization.

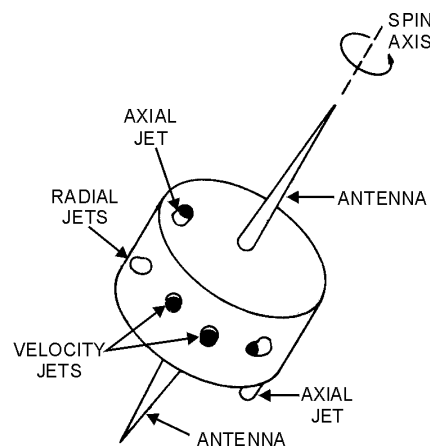

Figure 4-9.—Spin-stabilized satellite controls.

Solar cells are installed around the outside surface of a spin-stabilized satellite. This gives you a large number of solar cells exposed to the sun at all times (except when the satellite is in eclipse). The use of omnidirectional antennas causes a small part of the total radiated energy to be directed toward the earth at all times.

Omnidirectional antennas radiate only a small amount of energy toward the earth. Many techniques have been tried to achieve an earth-oriented antenna system. One system developed uses spin stabilization for orientation of the satellite. It uses a stationary inner platform for mounting remote controlled antennas. The satellite is constructed in two parts with both parts having radial jets. The inner platform contains the communications antennas and the communications package. After the satellite is stabilized in space, inner radial jets spin the inner platform. The inner platform is stationary with respect to earth and is oriented to such a position that the communications antennas point continuously toward the earth. This arrangement allows the use of high-gain directional antennas that concentrate the majority of the radiated energy in the direction of the earth.

The latest versions of communications satellites use a stationary platform with four high-gain antennas. Two steerable narrow beam antennas are used for communications between and within regions of high traffic density. Two horn antennas provide for earth communications between facilities outside the narrow beam coverage. The antenna arrangement for these types of communications satellites is shown in figure 4-7.

Q5. What was the major operational limitation of early communications satellites?

Q6. Satellite orientation in space is important for what two reasons?

EARTH TERMINAL CHARACTERISTICS

Communications satellite earth terminals are usually located in areas remote from the actual users of these communications. This is necessary to minimize rf interference to the satellite.

Locating the terminals in these remote locations requires interconnecting communications links. Links permit communications flow to and from the users of the satellite systems. Interconnect links are usually connected via telephone cables or microwave radio links with normal terminal equipment.

Earth satellite communications terminals generally have a single, large antenna; a highly sensitive receiver; a powerful transmitter; multiplex equipment; modulating-demodulating equipment; and telemetry equipment. Each of these elements will be discussed later in this chapter.

Antennas

Earth terminal antennas are highly directional, high-gain antennas capable of transmitting and receiving signals simultaneously. Generally, large, high-gain, parabolic antennas are used.

Generally speaking, three sizes of parabolic-type antennas are currently in use at earth terminal sites. These are a parabolic antenna sixty feet in diameter, a parabolic antenna forty feet in diameter, and a cluster of four parabolic antennas, each ten feet in diameter. These four in combination are equal to a parabolic antenna eighteen feet in diameter. They are shown in figures 4-10, 4-11, and 4-12, respectively.

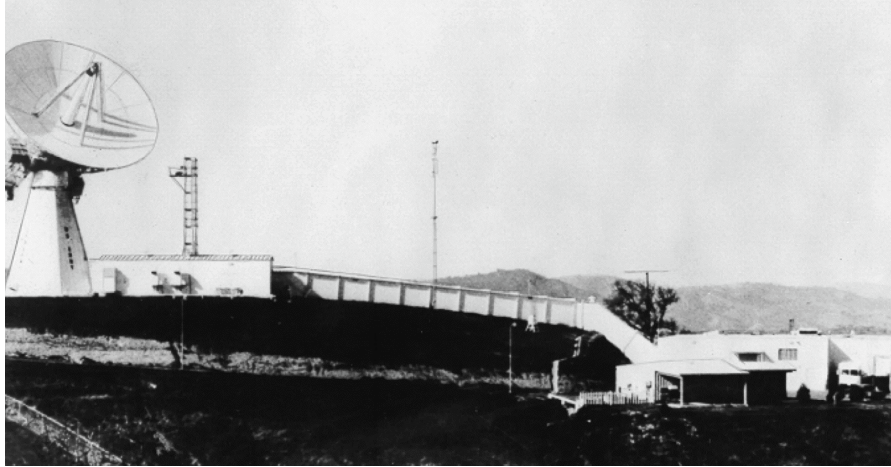

Figure 4-10.—Typical satellite earth terminal with sixty-foot antenna.

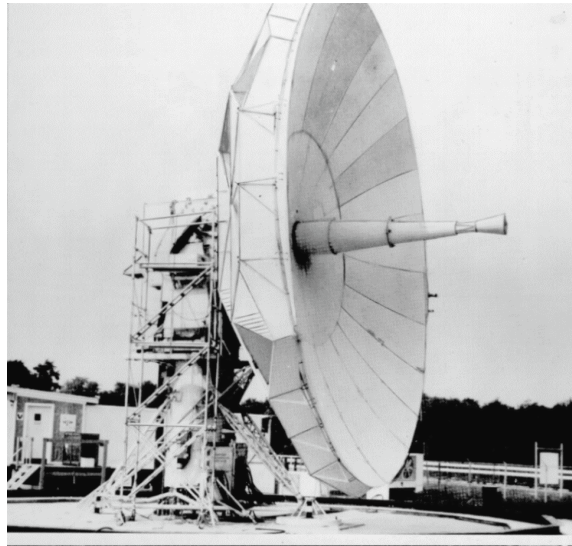

Figure 4-11.—Forty-foot antenna and pedestal.

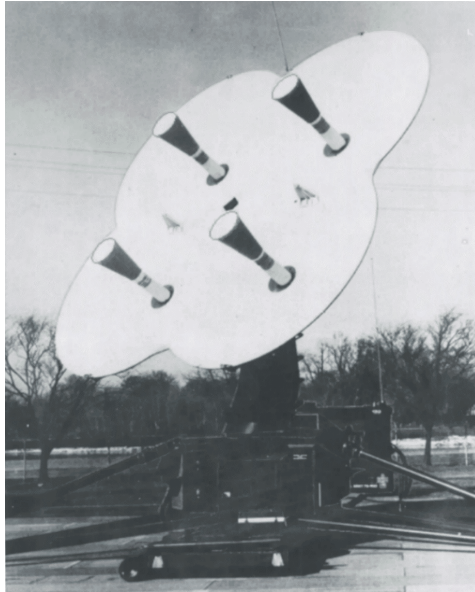

Figure 4-12.—Parabolic antenna cluster.

Receivers

All satellite communications earth terminals are equipped with specially designed, highly sensitive receivers. These receivers are designed to overcome down-link power losses and to permit extraction of the desired communications information from the weak received signal. The terminals currently in use have specially designed preamplifiers mounted directly behind the antennas.

Transmitters

All earth terminal transmitters generate high-power signals for transmission to the communications satellites. High-powered transmitters and highly directional, high-gain antennas are combined in this configuration. This is necessary to overcome up-link limitations and to ensure that the signals received by the satellite are strong enough to be detected by the satellite. Each transmitter has an exciter/modulator and a power amplifier. The modulator accepts the input signal from the terminal equipment and modulates an IF carrier. The exciter translates the IF signal to the up-link frequency and amplifies it to the level required by the power amplifier.

Transmitters used in earth terminals have output power capabilities that vary from 10 watts to 20 kilowatts, depending on the type used and the operational requirements.

Telemetry Equipment

Telemetry equipment is included in all communications satellite systems. This permits monitoring of the operating conditions within the satellite. Telemetry can be used also for remote control of satellite operations, such as energizing axial jets for changing the spin axis of the satellite.

Q7. What type of antennas are generally used at earth terminals?

Q8. Why do earth terminals require highly sensitive receivers?

Q9. What is the range of earth terminal transmitter output power?

SHIPBOARD RECEIVE-ONLY EQUIPMENT SYSTEMS

The purpose of a shipboard receive-only system is to receive fleet multichannel teletypewriter broadcasts, which, as you recall from chapter 1, require no receipt. These are transmitted from a ground station and relayed to naval vessels by satellite.

Figure 4-13 is a typical shipboard receive-only system. In this system the transmitted carrier may be frequency modulated (fm) or phase-shift-key (psk) modulated for tty operation. The receiving antennas for this system are positioned about the ship. They are arranged in a manner (normally one in each quadrant of the ship) that at no time allows the line-of-sight to be blocked between the relay satellite and one or more of the antennas. Incoming signals pass from the antennas to an amplifier-converter. Each amplifier-converter routes an IF signal on one line of a twin axial cable that connects it to the combiner-demodulator. An operating power and local-oscillator signal are coupled from the combiner-demodulator to each amplifier-converter on the other line of the cable used for the IF signal. Because of signal path variations, shading, and reflections, the incoming signals are subject to random phase and amplitude variations. The combiner operation performed within the combiner-demodulator removes the phase variations from each input signal. It then measures the amplitudes of the signals for optimum combining and sums the signals. After being combined, the signal is demodulated and coupled from a receiver transfer switchboard to a telegraph demultiplex terminal.

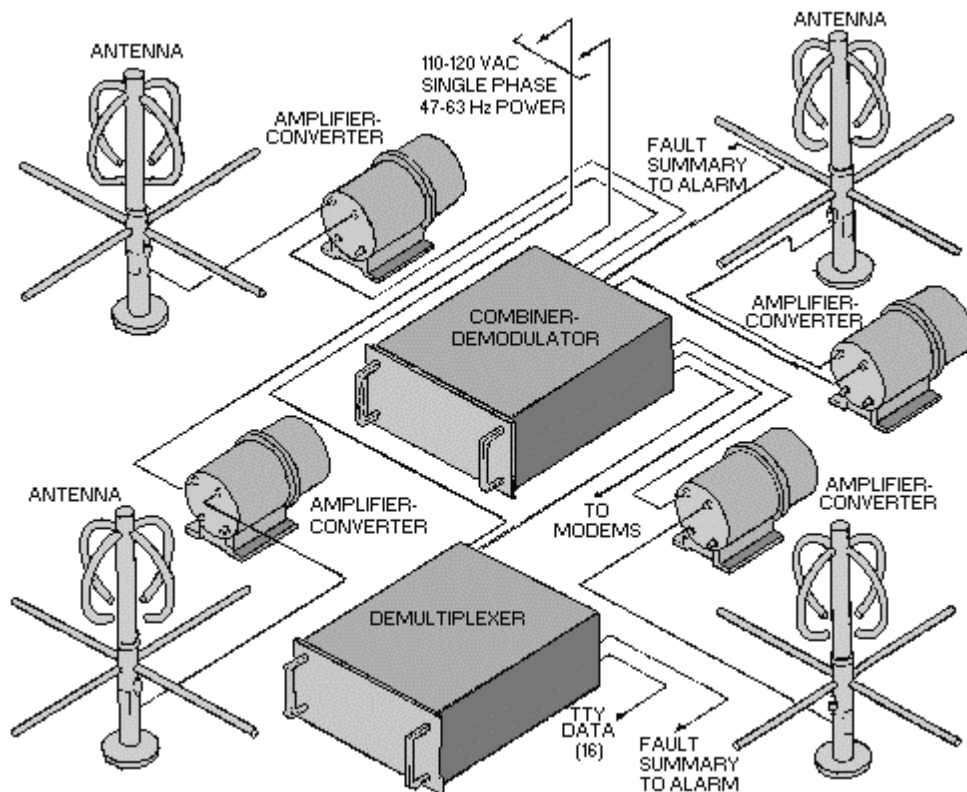

Figure 4-13.—Typical shipboard receive only system.

Q10. What is the function of shipboard receive-only equipment?

Q11. What types of modulation are shipboard receive-only equipment designed to receive?

SATELLITE ACQUISITION AND TRACKING

An essential operation in communicating by satellite is the acquisition (locating) of the satellite by the earth terminal antenna and the subsequent tracking of the satellite. Initial acquisition depends upon an exact knowledge of the position of the satellite. In combination with the geographic location of the earth terminal, knowing the position of the satellite enables you to compute accurate antenna pointing information. The degree of difficulty in locating and tracking a satellite is determined largely by what type orbit the satellite is in.

The locating and tracking of a synchronous satellite is relatively simple. This is because the satellite appears to be stationary. Locating a near-synchronous satellite is also relatively simple because of the slow relative motion of the satellite. However, the movement of a near-synchronous satellite is enough that accurate tracking is required to keep the narrow beam antenna pointed toward the satellite. Satellites in medium altitude circular orbits or in elliptical orbits are more difficult to acquire and to track because of the rapid changes in position.

Orbital Prediction

To acquire and track a satellite in space, the earth terminal antennas must be provided with very accurate pointing information. Antenna pointing information is based upon the orbital prediction of the satellite. This information is derived from an EPHEMERIS table. This table provides the coordinates of a satellite or a celestial body at specific times during a given period. After you know the ephemeris data of a satellite, you can predict for any given location the apparent track of the satellite as viewed from that location.

The constants defining an orbit are initially obtained by the process of tracking. At the time of launch, the rocket is tracked by radar from lift-off to orbit and then until it passes out of sight. Tracking data obtained in this way is sufficient for making rough predictions of the orbit. These predictions are made rapidly with a computer and sent to tracking stations all over the world. These other tracking stations watch for the satellite during its first trip and record additional data. During the first week of orbiting, tracking stations all around the world are obtaining progressively more accurate data concerning the Satellite. This data is put into a computer where corrections of earlier estimates of the orbit are made.

Once the initial predictions are complete and the satellite link becomes operational, very little change in these calculations is made. The orbits of a satellite will change slightly over a period of time; however, these changes are so gradual that predictions will be accurate enough to be used for weeks or even months without further corrections. When the orbits are known precisely, an ephemeris can be calculated for each satellite of the system.

Antenna Pointing

Antenna pointing instructions for each satellite must be computed separately for each ground station location. A satellite that bears due south of station A at an elevation of 25 degrees may simultaneously bear due southeast of station B at an elevation of 30 degrees. Antenna pointing instructions are determined by taking into consideration the orbital prediction and the latitude and longitude of each ground station.

To establish radio contact with a satellite, the ground station needs to know the bearing and elevation of a satellite. This allows the antenna to be properly pointed.

Acquisition

The acquisition of satellite signals by a ground station equipped with large antennas and operated at microwave frequencies places severe requirements on the system. Several factors must be considered. These factors are discussed below:

SPATIAL-TIME FACTOR.—Very accurate antenna pointing information is available to earth terminals from the satellite control facility located in Sunnyvale, California. Because of equipment limitations, a small search about the predicted location of the satellite must often be conducted to make initial contact. Either a manual or automatic scan is made around a small area close to the point where the satellite appearance is predicted.

FREQUENCY CONTROL.—The frequency of a radio signal received from a satellite is not generally the exact assigned down-link frequency. This variation depends upon the type of orbit of the satellite. The greatest frequency variations in signals from satellites occur in medium altitude circular or elliptical orbits. The smallest frequency variations occur in signals from satellites in near-synchronous or synchronous orbits.

Tracking

When a particular satellite has been acquired, the earth terminal antenna will track that satellite for as long as it is used as a communications relay. Several methods of tracking are in actual use; however, we will explain PROGRAMMED TRACKING and AUTOMATIC TRACKING.

PROGRAMMED TRACKING.—In programmed tracking the known orbital parameters of the satellite are fed into computation equipment to generate antenna pointing angles. The antenna pointing angles are fed as commands to the antenna positioning servomechanisms. (You may want to review servos in NEETS, Module 15, *Principles of Synchros, Servos, and Gyros*.) These point the antenna in the required direction. The amount of data and computations involved in using programmed tracking is extensive. These are a result of the antenna mount flexing and atmospheric and ionospheric bending of radio waves. Because of these uncertainties, programmed tracking is not used extensively.

AUTOMATIC TRACKING.—In automatic tracking, the equipment generates antenna pointing information by comparing the direction of the antenna axis with the direction from which an actual satellite signal is received. Automatic tracking systems track the apparent position of a satellite. The direction of arrival of the radio signal and the real position of the satellite is not required. The automatic tracking system uses a servomechanism to move the antenna. Once the satellite has been located, the servomechanism generates its own pointing data. This eliminates the requirement for continuous data input and computation.

SATELLITE OUTAGE TIME.—The satellite outage time specifications allow for stewing (moving) the earth terminal antennas, acquiring the satellite signal, and checking for circuit continuity at HAND OVER. (Hand over is the period of time for one earth terminal to yield control to another as a satellite moves out of its area of coverage.) This hand over period represents an outage time. If the control terminal is unable to hand over to another terminal within a specified time, other arrangements are made. For example, control may be retained or transferred to another terminal within the coverage area. There are several reasons why a terminal may be unable to assume control on time; these reasons may combine to increase the outage time. The difference of drift velocities of the satellites leads to bunching within a coverage area. This causes gaps in coverage and increases outage times. When two or more satellites simultaneously occupy the same space of the terminal antennas, they will interfere with each other. This prevents reliable communications. Other factors leading to increased outage times are SATELLITE-SUN CONJUNCTION (increased noise while the satellite passes near the sun), SATELLITE ECLIPSE

(absence of power from solar cells), and satellite failures. The distribution of outage times is a complicated function of time and earth-station locations. With careful coverage coordination, maximum communications effectiveness is obtained.

Q12. Why is satellite acquisition and tracking important?

ROLE OF SATELLITE COMMUNICATIONS

In the context of a worldwide military communications network, satellite communications systems are very important. Satellite communications links add capacity to existing communications capabilities and provide additional alternate routings for communications traffic. Satellite links, as one of several kinds of long-distance links, interconnect switching centers located strategically around the world. They are part of the defense communication systems (DCS) network. One important aspect of the satellite communications network is that it continues in operation under conditions that sometimes render other methods of communications inoperable. Because of this, satellites make a significant contribution to improved reliability of Navy communications.

ADVANTAGES OF SATELLITE COMMUNICATIONS

Satellite communications have unique advantages over conventional long distance transmissions. Satellite links are unaffected by the propagation variations that interfere with hf radio. They are also free from the high attenuation of wire or cable facilities and are capable of spanning long distances. The numerous repeater stations required for line-of-sight or troposcatter links are no longer needed. They furnish the reliability and flexibility of service that is needed to support a military operation.

Capacity

The present military communications satellite system is capable of communications between backpack, airborne, and shipboard terminals. The system is capable of handling thousands of communications channels.

Reliability

Communications satellite frequencies are not dependent upon reflection or refraction and are affected only slightly by atmospheric phenomena. The reliability of satellite communications systems is limited only by the equipment reliability and the skill of operating and maintenance personnel.

Vulnerability

Destruction of an orbiting vehicle by an enemy is possible. However, destruction of a single communications satellite would be quite difficult and expensive. The cost would be excessive compared to the tactical advantage gained. It would be particularly difficult to destroy an entire multiple-satellite system such as the twenty-six random-orbit satellite system currently in use. The earth terminals offer a more attractive target for physical destruction. These can be protected by the same measures that are taken to protect other vital installations.

A high degree of freedom from jamming damage is provided by the highly directional antennas at the earth terminals. The wide bandwidth system that can accommodate sophisticated anti-jam modulation techniques also lessens vulnerability.

Flexibility

Most operational military satellite earth terminals are housed in transportable vans. These can be loaded into cargo planes and flown to remote areas. With trained crews these terminals can be put into operation in a matter of hours. Worldwide communications can be established quickly to remote areas nearly anywhere in the free world.

SATELLITE LIMITATIONS

Limitations of a satellite communications system are determined by the technical characteristics of the satellite and its orbital parameters. Active communications satellite systems are limited by two things. Satellite transmitter power on the down links and receiver sensitivity on the up links. Some early communications satellites have been limited by low-gain antennas.

Power

The amount of power available in an active satellite is limited by the weight restrictions imposed on the satellite. Early communications satellites were limited to a few hundred pounds because of launch-vehicle payload restraints. The only feasible power source is the inefficient solar cell. (Total power generation in the earlier satellites was less than 50 watts.) As you can see, the rf power output is severely limited; therefore, a relatively weak signal is transmitted by the satellite on the down link. The weak transmitted signal is often reduced by propagation losses. This results in a very weak signal being available at the earth terminals. The level of signals received from a satellite is comparable to the combination of external atmospheric noise and internal noise of standard receivers. Special techniques must be used to extract the desired information from the received signal. Large, high-gain antennas and special types of preamplifiers solve this problem but add complexity and size to the earth terminal. (The smallest terminal in the defense communication systems network has effectively an 18-foot antenna and weighs 19,500 pounds.) Development of more efficient power sources and relaxation of weight restrictions have permitted improved satellite performance and increased capacity.

Receiver Sensitivity

Powerful transmitters with highly directional antennas are used at earth stations. Even with these large transmitters, a lot of signal loss occurs at the satellite. The satellite antenna receives only a small amount of the transmitted signal power. A relatively weak signal is received at the satellite receiver. This presents little problem as the strength of the signal received on the up link is not as critical as that received on the down link. The down-link signal is critical because the signal transmitted from the satellite is very low in power. Development of high-gain antennas and highly sensitive receivers have helped to solve the down-link problem.

Availability

The availability of a satellite to act as a relay station between two earth terminals depends on the locations of the earth terminals and the orbit of the satellite. All satellites, except those in a synchronous orbit, will be in view of any given pair of earth stations only part of the time. The length of time that a nonsynchronous satellite in a circular orbit will be in the ZONE OF MUTUAL VISIBILITY (the satellite can be seen from both terminals) depends upon the height at which the satellite is circling. Elliptical orbits cause the satellite zone of mutual visibility between any two earth terminals to vary from orbit to orbit. These times of mutual visibility are predictable. Figure 4-14 illustrates the zone of mutual visibility.

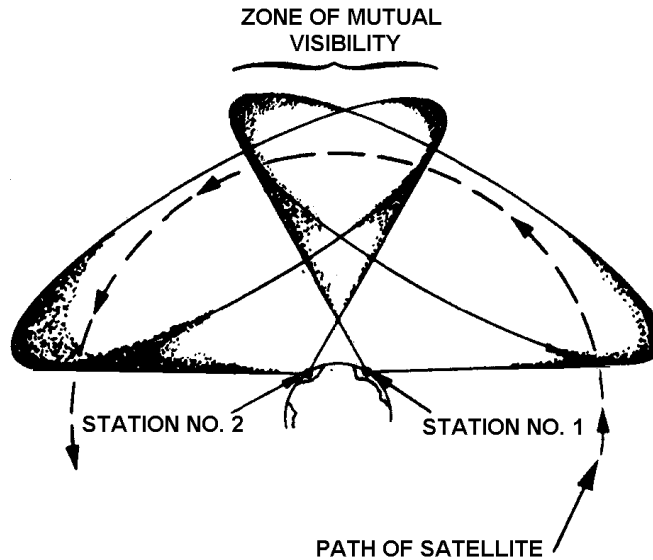

Figure 4-14.—Zone of mutual visibility.

Q13. *What are the two limitations to an active satellite communications system?*

FUTURE SATELLITE COMMUNICATIONS

Satellite communications are becoming well established in the Navy. In October 1983 the Department of the Navy established the Naval Space Command, which assumed operational responsibility for Navy space systems plus coordination responsibility with other operational activities. Most ships have satellite communications capability. New systems have been installed on ships and are fully compatible with other electronic systems and equipment. Communications via satellite has increased existing Navy communications capabilities for the command and control of naval forces. Satellite communications has not replaced all existing means of radio communications. However, it is a major step in modernizing Navy communications. It has relieved the Navy of its total dependence on hf radio transmission and reduced the need for many hf ground stations overseas.

A recent step in the advancement of satellite communications was the start of the DSCS Phase III. The first Phase III satellite was launched into orbit by the space shuttle in the summer of 1984. Seven satellites will be placed in space during this phase. Figure 4-15 shows a Phase III satellite being tested in a simulated space environment, Figure 4-16 shows the Phase III satellite as it appears in space. Phase III will develop the use of 40-watt, solid-state amplifiers to replace the currently used traveling-wave tube (twt). It will also be used to develop new type filters. These filters will provide increased channel bandwidth, which will provide additional communications capacity.

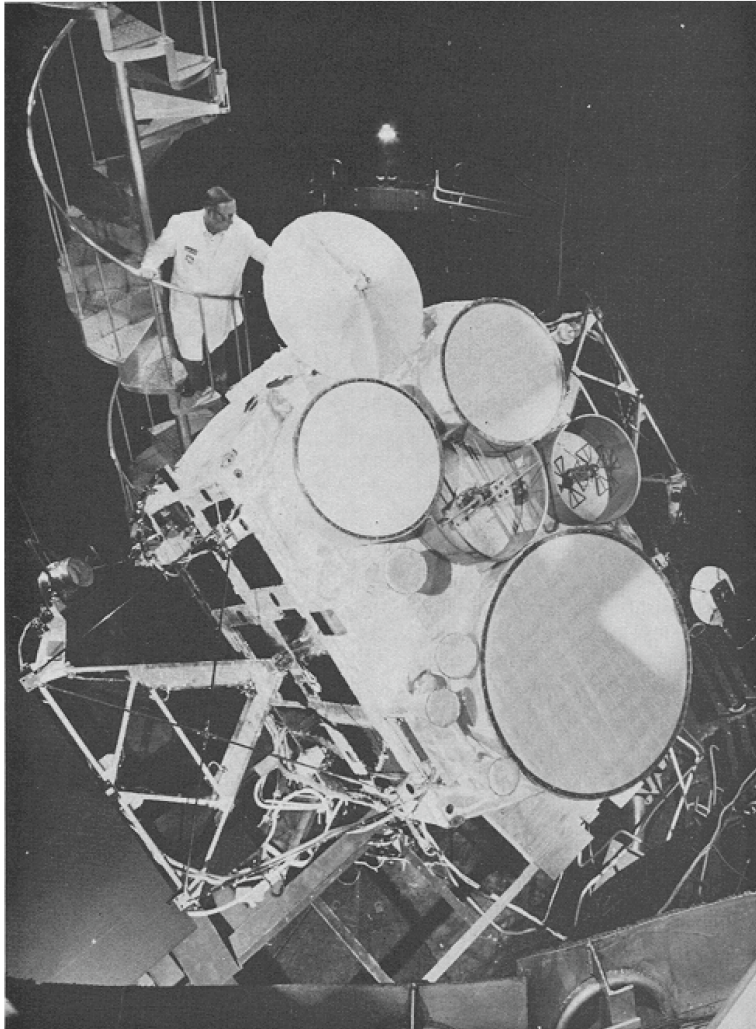

Courtesy of Martin Marietta Astro Space, Copyright © All rights reserved

Figure 4-15.—DSCS Phase III satellite being tested.

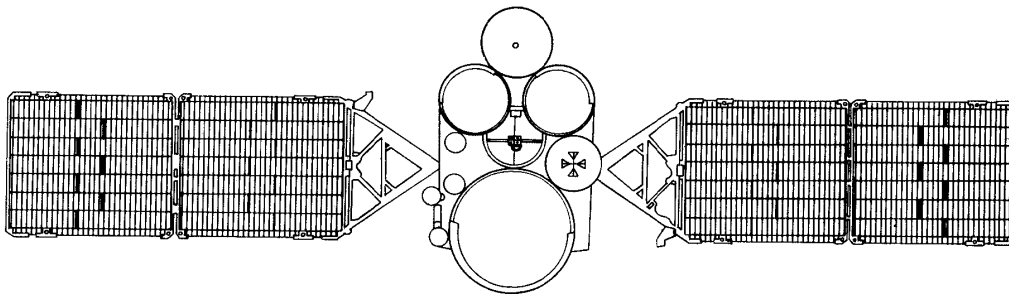

Courtesy of Martin Marietta Astro Space, Copyright © All rights reserved

Figure 4-16.—DSCS Phase III satellite as it appears in space.

The survivability of reliable communications for the command and control of our strategic nuclear forces is paramount. Space systems perform many missions more effectively than earthbound systems.

Spaceborne communications increase the effectiveness of military operations. The Department of Defense is engaged in the development of new communications techniques and systems, including some that are space based. As the use of space continues its march forward, vital new opportunities for national defense will continue to materialize. This will improve the survivability of our strategic communications against nuclear and electronic attack.

More information on satellite communications can be found in Navy publication NTP 2, *Navy Satellite Operations*. This publication was written to concisely explain the role of the Navy in the Defense Communications Satellite Program. It also issues procedures for effective, coordinated use of available satellite resources.

SUMMARY

Now that you have completed this chapter, a short review of what you have learned will be helpful. The following review will refresh your memory of satellite communications, equipment, and theory.

A **PASSIVE SATELLITE** is one that reflects radio signals back to earth.

An **ACTIVE SATELLITE** is one that amplifies the received signal and retransmits it back to earth.

REPEATER is another name for an active satellite.

The **UP LINK** is the frequency used to transmit a signal from earth to a satellite.

The **DOWN LINK** is the frequency used to transmit an amplified signal from the satellite back to earth.

A **SYNCHRONOUS ORBIT** is one in which the satellite moves or rotates at the same speed as the earth.

An **ASYNCHRONOUS ORBIT** is one where the satellite does not rotate or move at the same speed as the earth.

A **NEAR SYNCHRONOUS ORBIT** is one in which the satellite rotates close to but not exactly at the same speed as the earth.

PERIGEE is the point in the orbit of a satellite closest to the earth.

APOGEE is the point in the orbit of a satellite the greatest distance from the earth.

The **ANGLE OF INCLINATION** is the angular difference between the equatorial plane of the earth and the plane of orbit of the satellite.

INCLINED ORBITS are orbits where there is some amount of inclination. These include equatorial and polar orbits.

An **EQUATORIAL ORBIT** is an orbit that occurs when the plane of a satellite coincides with the plane of the earth at the equator.

A **POLAR ORBIT** is an orbit that has an angle of inclination of or near 90 degrees.

A **MEDIUM ALTITUDE ORBIT** is an orbit from 2,000 to 12,000 miles above the earth. The rotation rate of the earth and satellite are quite different, and the satellite moves quickly across the sky.

An **ECLIPSE** is when the satellite is not in view or in direct line of sight with the sun. This happens when the earth is between them.

An **EPHEMERIS** is a table showing the precalculated position of a satellite at any given time.

PROGRAMMED TRACKING uses known satellite orbital parameters to generate antenna pointing angles.

AUTOMATIC TRACKING is done by the equipment comparing the direction of the antenna axis and the direction of the received signal.

HAND OVER is the period of time for one earth terminal to yield control to another as a satellite moves out of its area of coverage.

SATELLITE-SUN CONJUNCTION is when the satellite and sun are close together and the noise from the sun prevents or hampers communications.

A **SATELLITE ECLIPSE** is an eclipse where the rays of the sun don't reach the satellite. This prevents recharging of the solar cells of the satellite and decreases the power to the transmitter.

The **ZONE OF MUTUAL VISIBILITY** is where the satellite can be seen by both the up- and down-link earth terminals.

ANSWERS TO QUESTIONS Q1. THROUGH Q13.

- A1. Passive and active.*
- A2. Earth terminals.*
- A3. Approximately one-half.*
- A4. The extreme polar regions.*
- A5. The lack of suitable power sources.*
- A6. To allow maximum solar cell exposure to the sun and satellite antenna exposure to earth terminals.*
- A7. Large, high-gain parabolic antennas.*
- A8. To overcome satellite transmitter low power and permit extraction of the desired information from the received signal.*
- A9. Up to 20 kilowatts.*
- A10. To receive fleet multichannel tty broadcasts.*
- A11. Fm or psk.*
- A12. To ensure earth terminal antennas are always pointed towards the satellite.*
- A13. Satellite down-link transmitter power and up-link receiver sensitivity.*

CHAPTER 5

INTRODUCTION TO MISCELLANEOUS COMMUNICATIONS SYSTEMS AND EQUIPMENT

LEARNING OBJECTIVES

Upon completion of this chapter you will be able to:

1. Describe the basic operation of communications systems that operate at medium frequencies and below.
2. Describe the basic microwave line-of-sight communications system.
3. Describe the basic tropospheric scatter communications system.
4. Describe the objective/purpose of the naval tactical data system (NTDS).
5. Describe the naval tactical data system (NTDS) data transmission subsystems in terms of links.
6. Explain the various applications of portable communications equipment.
7. Define the term laser.
8. Describe the basic theory of operation of lasers
9. Describe the possible applications of lasers in communications.

INTRODUCTION

In the previous four chapters we've looked at communications equipment and systems that were used in several frequency ranges. Some have had many applications. In this chapter you will look at systems used in some portions of the rf spectrum that have not been covered in detail. We will also discuss the naval tactical data system (NTDS), which operates in the high-frequency and ultrahigh-frequency regions. Various portable communications equipments used in the military and an introduction to the laser and its uses in communications are included. Some of the applications presented are fairly new to the military community.

SYSTEMS

As discussed in chapter 1, the frequency range from elf to shf is from below 300 hertz up to 30 gigahertz. The first area we will cover is the lower frequency bands (medium frequency [mf] and below). You will then get a look at the microwave region and the high-frequency and ultrahigh-frequency range as it pertains to the naval tactical data system (NTDS).

MEDIUM FREQUENCY AND BELOW

Most of the receivers and transmitters that you will see used in the mf portions of the rf spectrum and below are very similar in design. In chapter 1 we discussed the operational uses of the equipment; now let's look at the equipment itself.

Equipment items covered in this and other chapters are meant to be merely representative of equipment that may be encountered in naval communications. No attempt will be made to include all of the possible equipment or equipment configurations.

Transmit Equipment

You should realize the transmitters used in bands of medium frequency and below are similar to those you studied in chapter 2. In other words, a transmitter used in one frequency range is basically the same as one used in another range. However, there are some differences. Two of the differences are component size and the use of a technique called DOUBLING UP.

The components used in bands of medium frequency and below are much larger physically than the ones previously discussed. This is because of the higher operating voltage and current levels required to produce the very high-powered rf outputs needed for the uses covered in chapter 1. A given resistor used in an hf application may be rated at 1/2 watt, whereas the same resistor used in a lower frequency application would probably be rated in tens or even hundreds of watts.

A block diagram of a doubled-up transmitter is shown in figure 5-1. Remember, bands of medium frequencies and below are used almost exclusively for broadcast and are on the air continuously. Doubling up increases reliability. As you can see, two transmitters are located in the same equipment cabinet. This allows you to quickly transfer circuits if one should fail. This dual installation also allows both amplifiers to be used together to double the output power. When you use this application, you sacrifice the doubling-up capability of only the power amplifier. All the other components are still available as backups. Let's go through figure 5-1 and describe the block functions.

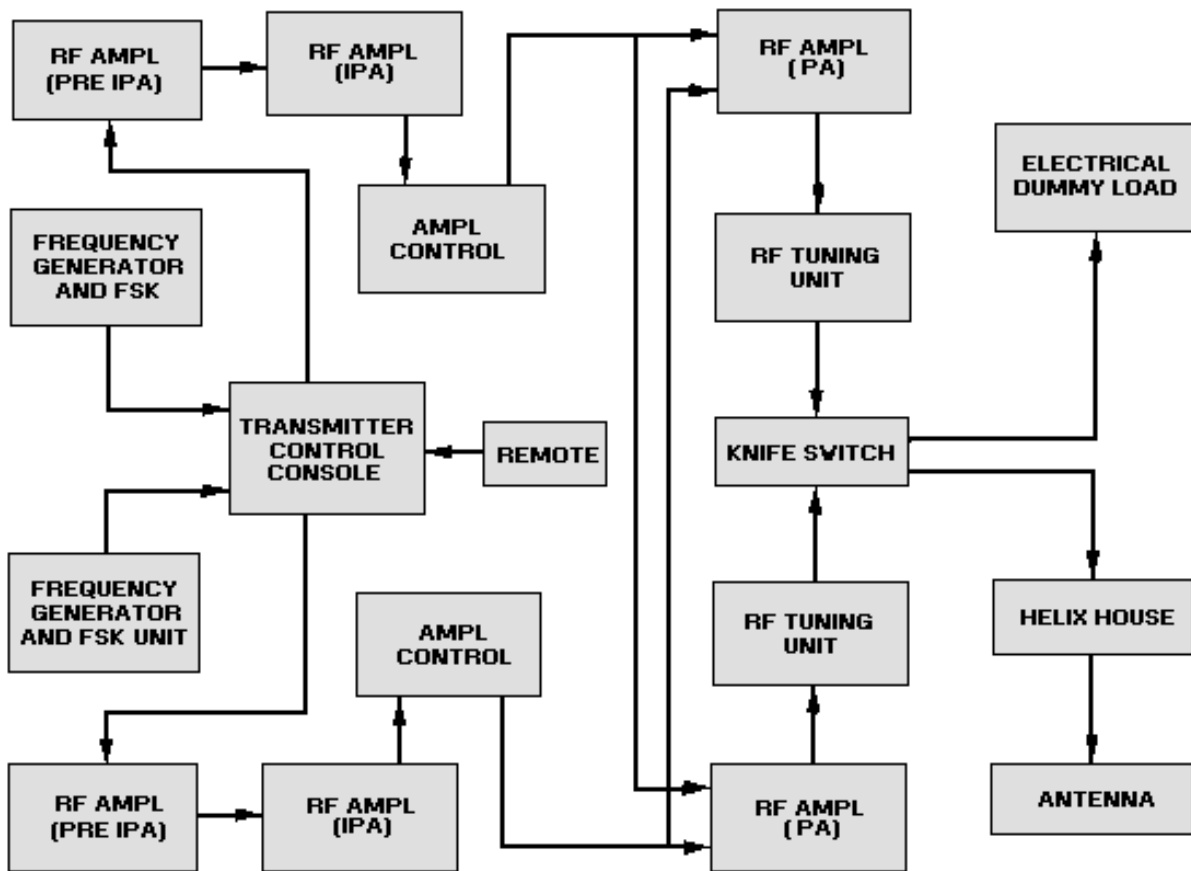

Figure 5-1.—Doubled-up transmitter block diagram.

The frequency generator part of the frequency generator and fsk block is an oscillator. It provides the carrier frequencies for the cw mode. The fsk part is a FREQUENCY SYNTHESIZER (a frequency source of high accuracy). It makes both the mark and space frequencies from a very stable clock oscillator. The keying pulses determine which fsk frequency the keyer chooses to transmit. This signal is then sent to the transmitter control console where it is distributed to the first rf amplifier. This amplifier is referred to as the preliminary intermediate-power amplifier (pre-ipa). The pre-ipa uses linear, untuned, push-pull, rf amplifiers to provide amplified rf to drive other rf amplifiers. The pre-ipa output goes to the intermediate power amplifier (ipa).

The ipa receives the pre-ipa output, amplifies the signal, and drives other selected power amplifiers. The ipa is a single-stage, untuned, linear, push-pull, rf circuit that uses water and forced-air cooled tubes.

Signals are then sent through the amplifier control, where they are used for signal monitoring purposes before being applied to the final rf amplifier (pa). The pa amplifies the signal to the final desired power level. The pa also contains variometers (variable inductors) for coupling. This coupled output is fed to the rf tuning unit.

The rf tuning unit consists of variable oil-filled capacitors and a fixed inductor for frequency tuning. The signal is then sent to a knife switch. This switch simply routes the signal to the DUMMY LOAD or the antenna by way of the HELIX HOUSE. (A dummy load is a nonradiating device that absorbs the rf

and has the impedance characteristics of the antenna.) The dummy load is impedance matched to the pa. It allows testing of the pa without putting a signal on the air. When the equipment is in an operating mode, the dummy load is not used. The helix house is a small building physically separated from the transmitter location. It contains antenna loading, coupling, and tuning circuits. The main components consist of a HELIX (large coil) and variable inductors. The signal is fed from the helix directly to the antenna. Sometimes two antennas are used.

Antenna designs vary with the amount and type of land available, desired signal coverage, and bandwidth requirements. Figure 5-2 shows a simplified transmit antenna. The Navy uses TOP-HAT (flat-top) capacitive loading with one or more radiating elements. Typical top hat antennas consist of two or more lengths of wire parallel to each other and to the ground, each fed at or near its mid point. The lengths of wire are usually supported by vertical towers. These antennas may take many shapes. The matching network shown is in the helix house. Figure 5-3 shows the installation at the naval communications unit in Cutler, Maine. The Navy has several of these types of installations. They are used primarily for fleet broadcasts and have power outputs in the .25- to 2-megahertz range. You should notice the transmitter, the location of the helix houses, and the dual antennas. You should also notice the transmission line tunnel. It is underground and over a half-mile long. Figure 5-4, view (A) and view (B), shows another antenna configuration. This array of monopoles (quarter-wave, vertically polarized stubs) is referred to as a TRIATIC antenna. A triatic antenna is a special form of a rhombic-arranged monopole array. This type of array is designed to transmit from a particular location. Triatics are all basically the same but have some design differences at each site. The physical differences compensate for differences in terrain. Now that we have looked at the transmit side, let's look at the receive side.

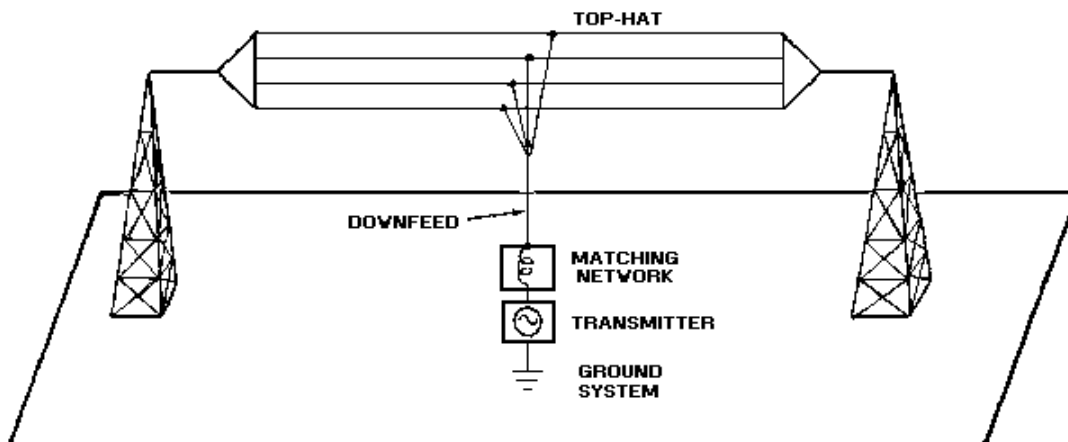

Figure 5-2.—Simplified vlf transmitting antenna.

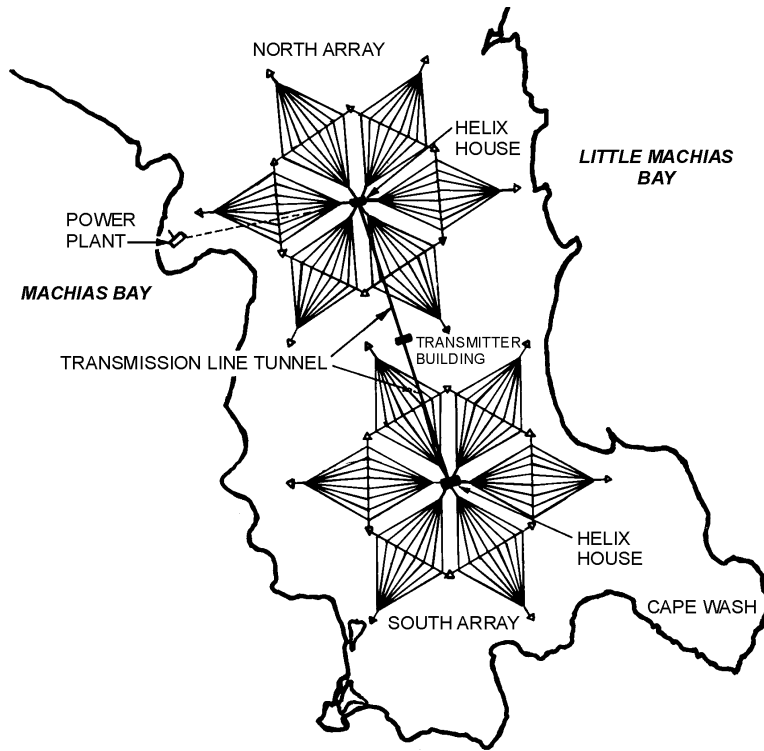

Figure 5-3.—Cutler, Maine antenna installation.

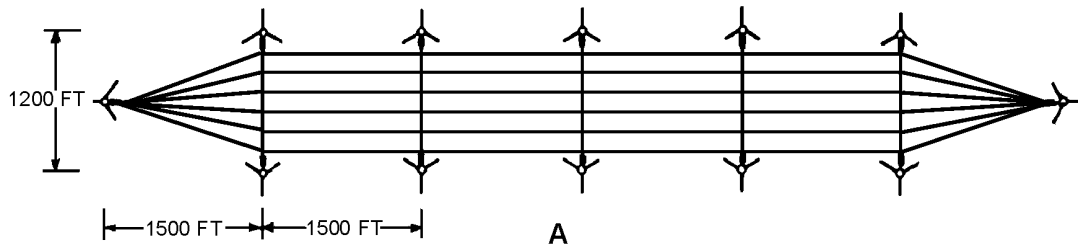

Figure 5-4A.—Triatic type antenna.

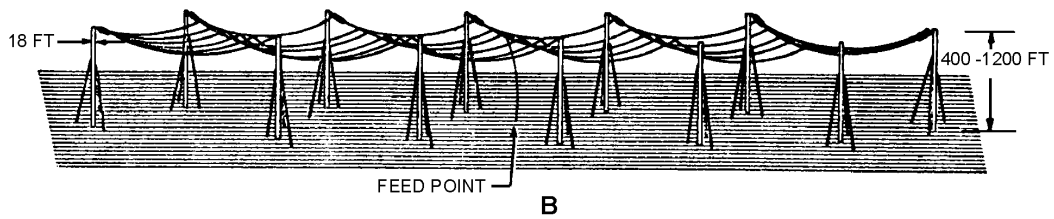

Figure 5-4B.—Triatic type antenna.

Receive Equipment

The receiver you will study here is fundamentally the same as those we covered in chapter 2. A receiver used in this frequency range is about the same electrically as one used in any other range. Figure 5-5 shows the receiver we will discuss. It is a highly sensitive, special purpose receiver because it is capable of splitting-out multiplex signals for detection and reproduction. This receiver covers the frequency range of 3 kilohertz to 810 kilohertz in five bands. It will receive most types of signals, including AM, cw, ssb, fm, and fsk. All operator controls are on the front panel, and a speaker and headset jack permit monitoring.

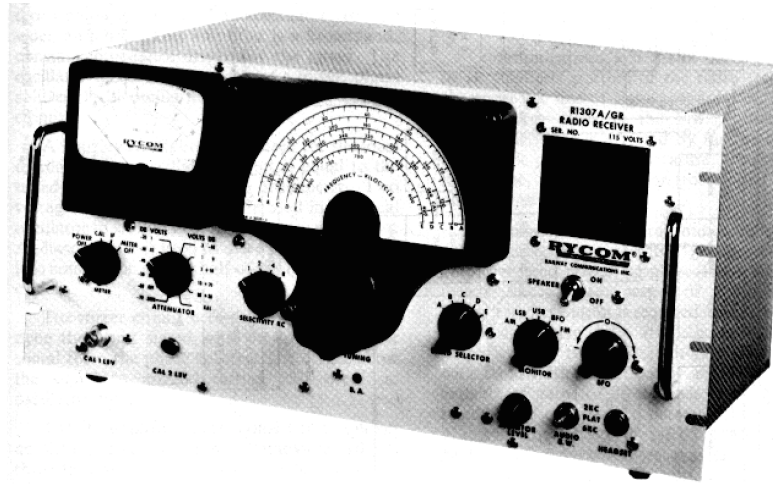

Figure 5-5.—Typical vlf to mf receiver.

Our receiver has five basic stages excluding the power supply. With the exception of a video amplifier in place of an rf amplifier, the circuits perform the functions normally associated with a typical receiver. Figure 5-6 is a block diagram showing the signal paths of the receiver. The input stage consists of a low-pass filter, an attenuator, a calibration oscillator, and a video amplifier. The low-pass filter passes input frequencies below 900 kilohertz. These frequencies are passed to the attenuator, which sets the signal to the proper level to drive the mixer. This minimizes noise and distortion. The calibration oscillator produces a 250-kilohertz output. It is used to calibrate the receiver level and to check for tuning dial accuracy. The input signal is direct-coupled from the attenuator to the video amplifier. This amplifier is a broadband, constant-impedance driver for the mixer. The oscillator-mixer stage consists of a mixer, phase splitter, local oscillator, and frequency control circuits.

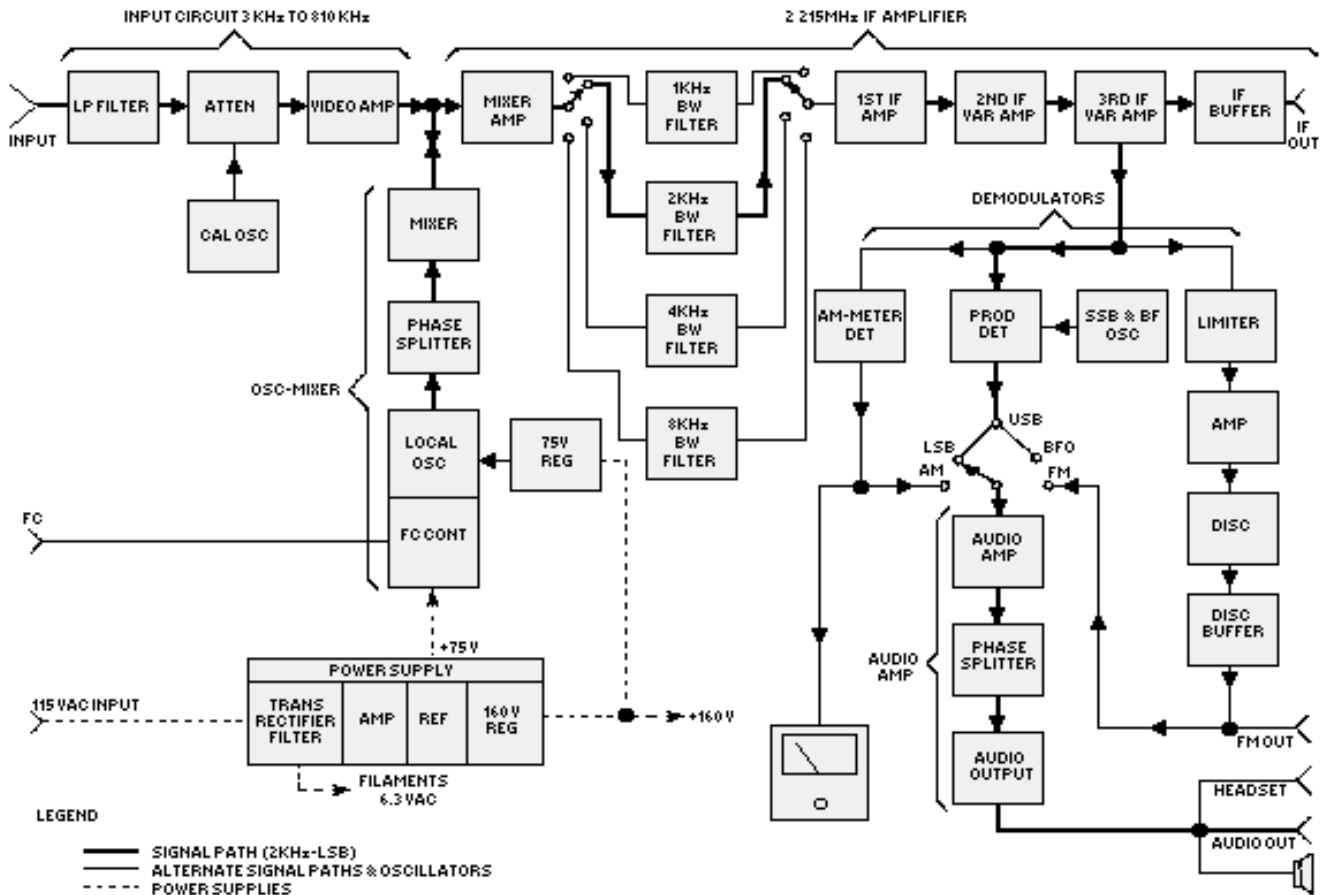

Figure 5-6.—Receiver block diagram.

A Hartley configuration is used for the local oscillator. The oscillator output is equal to the tuned frequency plus 2.215 megahertz. Two voltage-variable capacitors are used in the local oscillator to stabilize small frequency variations. A phase splitter is used to drive the mixer diodes into conduction during half of the local oscillator cycle.

The mixer circuit uses the diodes to heterodyne the input signal with the local oscillator signal from the phase splitter. The diodes short the signal to ground during half the local oscillator cycle.

The IF amplifier stages consist of the mixer amplifier, four selectable bandwidth filters, three IF amplifiers, and an IF buffer amplifier.

The output of the mixer is directly coupled to the mixer amplifier. The IF signal is then directed through one of four bandwidth filters to the first IF amplifier. The signal proceeds to the second and third IF amplifiers for amplification before demodulation. An IF buffer amplifier is used to pass the IF to the IF OUT jack and to isolate this jack from the rest of the circuitry.

Three demodulators are used in this receiver. They are the AM detector, product detector, and fm detector. The AM detector is used to demodulate AM signals. The product detector demodulates ssb, cw, and fsk signals, and the fm detector demodulates fm signals only. An output from the fm detector is provided to the FM OUT jack. This fm output may be used for recording or detailed analysis.

The output from the selected demodulator is amplified by the audio amplifier and presented simultaneously to the HEADSET jack, AUDIO OUT terminals, and the speaker.

You should note that this receiver, as with most others, requires no other special equipment. It uses a standard df loop or a whip antenna. If it is installed in a submarine, a trailed, (towed) long-wire antenna may be used.

MICROWAVE

Communications systems in the 1 gigahertz to 10 gigahertz portion of the radio frequency spectrum use line-of-sight propagation. Propagation takes place in the lower atmosphere (troposphere). It is affected by factors such as barometric pressure, temperature, water vapor, turbulence, and stratification (forming of atmospheric layers).

A typical microwave transmitter includes an exciter group, a modulator group, a power amplifier, and power supplies. The transmitter usually has a power output of about 1 watt. When a higher output is required (about 5 watts), a traveling-wave tube (twt) is used as the amplifier. (A twt is a high-gain, low-noise, wide-bandwidth microwave amplifier. It is capable of gains of 40 decibels or more, with bandwidths of over an octave. The twt was discussed in chapter 2 of NEETS, Module 11, *Microwave Principles*.) A typical microwave receiver contains an rf-IF group, local oscillator, demodulator, and amplifier. Both transmitters and receivers contain special circuits because of the high operating frequencies and critical frequency stability requirements.

Line-of-Sight System

A line-of-sight (los) microwave system consists of one or more point-to-point hops as shown in figure 5-7. Each hop is designed so that it can be integrated into a worldwide communications network. Los systems have many characteristics. In these systems, propagation is only affected by changes in the troposphere. The distance between microwave system hop points ranges from 50 to 150 kilometers (31 to 95 statute miles). These systems are capable of handling up to 600 4-kilohertz voice channels and can also transmit television. These signals can usually be transmitted with less than 10 watts of power. Both the transmit and receive antennas are horn-driven paraboloids that provide high gain and narrow beam widths. In some applications, as shown in figure 5-8, plane reflectors are used with the paraboloids. These systems are very reliable. They are designed to operate over 99 percent of the time. These systems are well adapted to multichannel communications and closed circuit television.

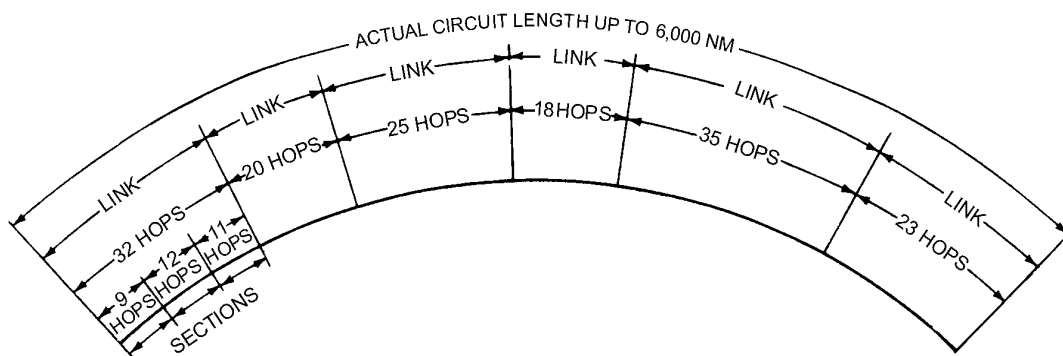

Figure 5-7.—Typical hop-link and section allocation.

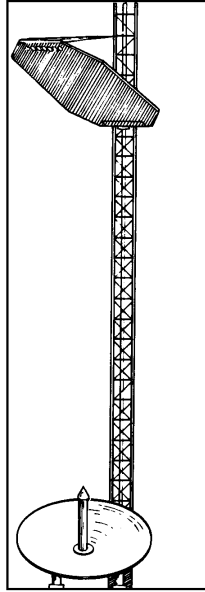

Figure 5-8.—Parabolic antenna and passive reflector combination.

Now let us take a look at another system. It is called the tropospheric-scatter microwave system. But first, you may want to review tropospheric propagation in NEETS, Module 10, *Introduction to Wave Propagation, Transmission Lines, and Antennas*.

Tropospheric Scatter System

A tropospheric-scatter (tropo-scatter) microwave system gets results similar to those of the line-of-sight system. It does it in a different way. The los system uses towers to relay information.

The tropo system uses the turbulence in the layer between the troposphere and the stratosphere to bounce signals back to earth. This method provides several hops and communications beyond los. The propagation reliability and communications capability is the same. The transmission range is up to 800 kilometers (500 statute miles). Transmitter output power may be up to 75 kilowatts depending on the operational requirements. The antennas are horn-driven paraboloids and may be as large as 50 to 60 feet in diameter. Figure 5-9 shows a typical tropospheric-scanner antenna. Remember that hf has a hop distance (skywave) of about 1,400 miles; the distance of one hop for a line-of-sight system is between 31 and 95 miles. The tropospheric-scatter system conveniently fills the gap between these distances.



Figure 5-9.—Mobile 30-foot tropospheric-scanner antenna.

Both of these systems are used ashore. You're now going to get a look at a shipboard data information exchange system.

- Q1. What is a dummy load?*
- Q2. What is the function of a product detector?*
- Q3. What is the frequency range of the mf band?*
- Q4. Microwave systems use what portion of the atmosphere?*
- Q5. What is the voice channel capacity of an los communications system?*
- Q6. What is the one-hop transmission range of a tropospheric-scatter system?*

NAVAL TACTICAL DATA SYSTEM

In recent years, the Navy has introduced several new highly technical and effective combat weapons systems. However, these weapons systems did not solve the basic combat command problems that confront our Navy. In combat, a fleet continues to be involved in close-range offense and defense. During close-range combat, the shipboard combat information center (CIC) is involved in complex tactical situations. These situations require intelligent and highly important decisions. Each decision has to be made in a short period of time. You will find the speed at which these combat situations must be solved is inconceivable to someone thinking in terms of typical CIC operations of the recent past. Therefore, the NTDS was developed by the U.S. Navy as a command tool for commanders in tactical combat situations.

Objectives

The naval tactical data system (NTDS) is based on the interaction of humans and machines. The NTDS helps coordinate fleet air defense, antisubmarine warfare, and surface defense operations. Through

automation, the NTDS provides commanders with a broad picture of the current tactical situation. It also assists them in directing their operations in time to intercept and destroy all potential enemy threats. The use of digital computers and digital data processing techniques reduces reaction time and increases force effectiveness.

NTDS uses a variety of equipment. This equipment includes transmitters, receivers, cryptographic equipment, high-speed digital computers, magnetic tapes, disks, and a variety of displays. Figure 5-10 shows the NTDS equipment grouping and how it interfaces with the weapons and sensor systems of a ship. Figure 5-11 shows the NTDS system inputs and outputs. As you can see, large amounts and various types of information are provided to or taken from the NTDS. Now that you have seen the types of information associated with the NTDS, let's look at how this information is transmitted and used.

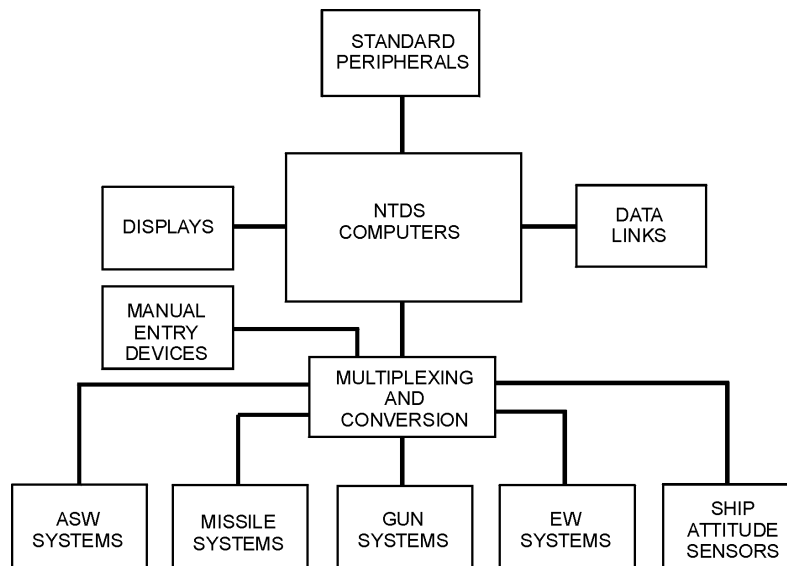

Figure 5-10.—NTDS equipment grouping.

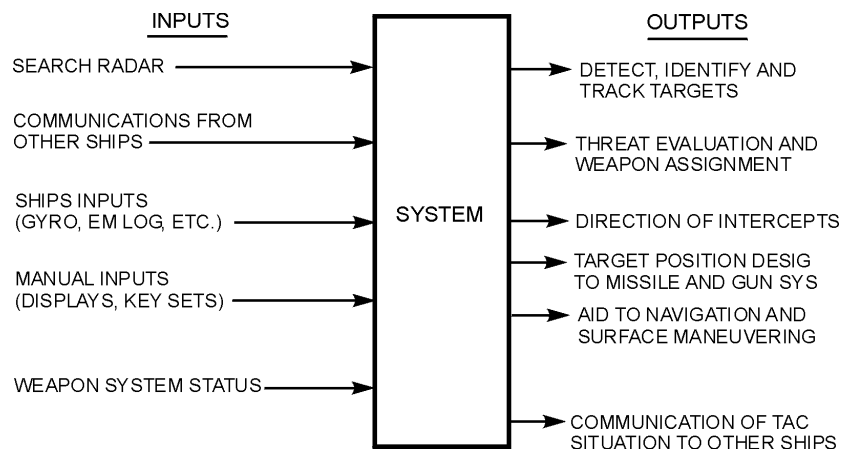

Figure 5-11.—NTDS system inputs/outputs.

NTDS Data Transmission Subsystems

NTDS uses three separate data transmission links to maintain tactical data communications between tactical units. Figure 5-12 illustrates these links. Each link is able to transfer data rapidly to other ships, aircraft, and shore facilities without the delay of human interface (link 14 receive is an exception to this). The data processing subsystem formats the messages for each of the data links. These messages are based on shipboard inputs (from displays, sensors, and other data links).

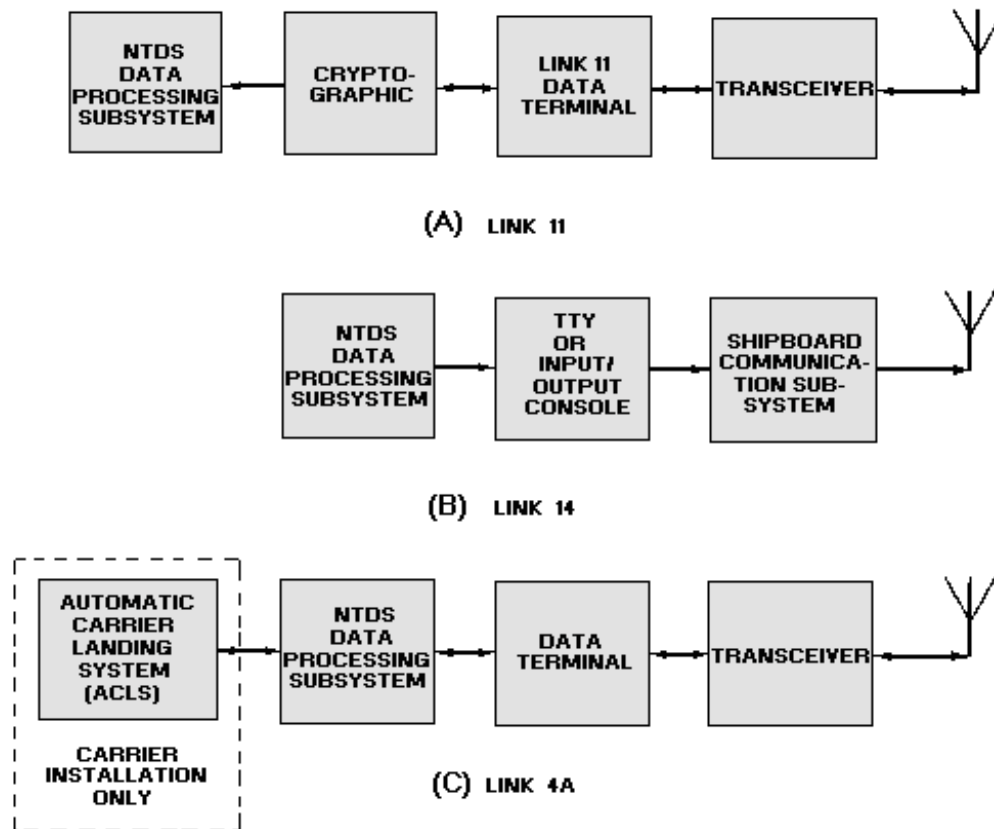

Figure 5-12.—NTDS communications links.

The automatic data communications links provide the operational commander with a high-speed, accurate mode of tactical communications. Link 11 provides high-speed, computer-to-computer transfer of tactical information, command orders, and unit status to all tactical data systems. View A shows you this configuration. The type of tactical information currently transferred is surface, subsurface, air, and EW track information. Data is provided on friendly, hostile, and unknown identity tracks. This broadcast originates through console button actions by the console operators.

Link 14 provides a means of transmitting track information to those units not capable of participating in the link 11 network. View B shows this network. This is a one-way broadcast of information.

Link 4A permits the computer to take control of the autopilot in an equipped aircraft. Also this link can control a plane under other situations. It may control a flight out to a strike area and return it to base without the need for pilot action. The pilot also has the option of overriding the link. The pilot may use the visual display to aid in understanding the intercept controller, or to totally ignore the link 4A

transmission. View C shows this link used in conjunction with the automatic carrier landing system (ACLS).

Figure 5-13 is a drawing of an intersystem communications employment diagram. It shows the overall possibilities and flexibility of the NTDS. The new terms shown are defined below:

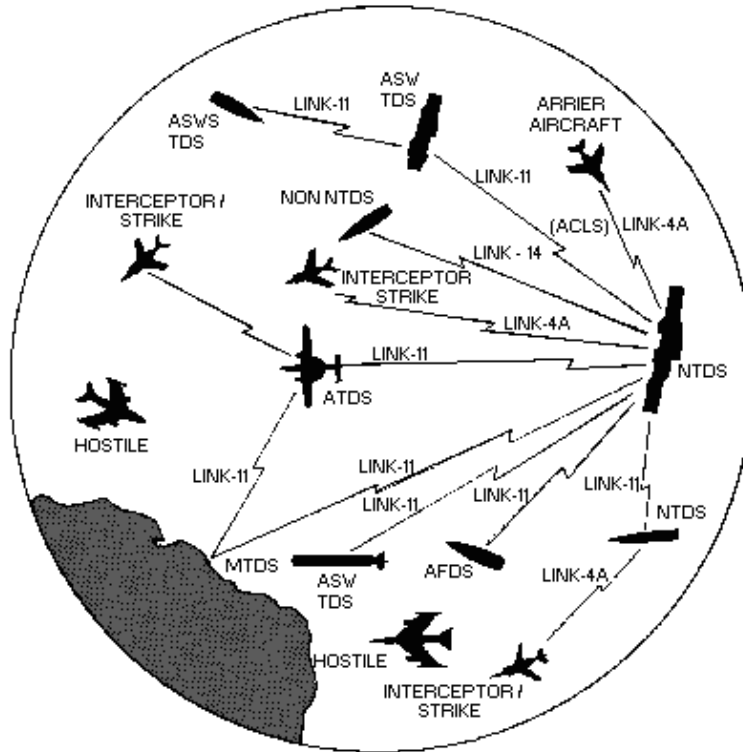

Figure 5-13.—Intersystem communications employment.

- MTDS-Marine tactical data system
- AFDS-Amphibious flagship data system
- ATDS-Airborne tactical data system
- ASWTDS-Antisubmarine warfare tactical data system

Now that we've looked at a complex and stationary system, let's study some fundamental portable equipment.

Q7. What is the primary advantage of NTDS over conventional systems?

Q8. What are the three NTDS data transmission subsystems?

PORTABLE EQUIPMENT

Portable and pack radio sets must be lightweight, compact, and self-contained. Usually, these sets are powered by a battery or a hand generator, have low output power, and are either transceivers or transmitter-receivers. A transceiver consists of a transmitter and a receiver that share common circuits and are housed in the same case or cabinet. A transmitter-receiver is the combination of two separate pieces of equipment that are used together. Navy ships carry a variety of these radio sets for emergency and amphibious communications. The numbers and types of equipment vary according to the individual ship.

EMERGENCY EQUIPMENT

One piece of emergency equipment is shown in figure 5-14. It is a rugged emergency transmitter carried aboard ships and aircraft for use in lifeboats and life rafts. The transmitter operates on the international distress frequency (500 kilohertz) and the survival craft communications frequency (8,364 kilohertz).

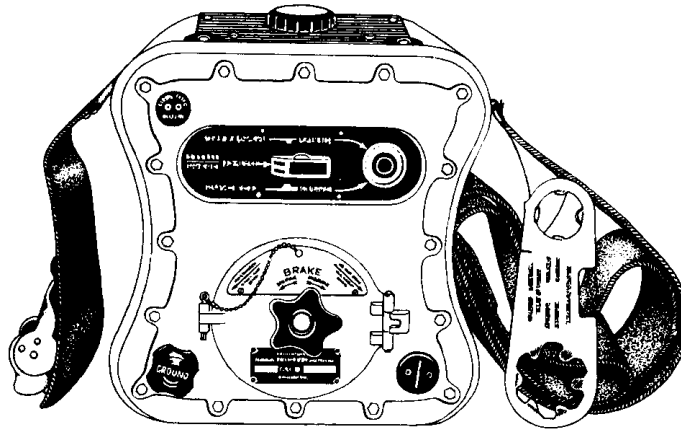

Figure 5-14.—Typical emergency lifeboat transmitter.

The complete radio transmitter, including the power supply, is contained in an aluminum cabinet that is airtight and waterproof. The cabinet is shaped to fit between the legs of the operator and has a strap for securing it in the operating position.

The only operating controls are a three-position selector switch and a push-button telegraph key. A hand crank screws into a socket in the top of the cabinet. The generator, automatic keying, and automatic frequency changing are all operated by turning the hand crank. While the hand crank is being turned, the set automatically transmits the distress signal SOS in Morse code. The code consists of six groups of SOS followed by a 20-second dash. It is transmitted alternately on 500 kilohertz and 8,364 kilohertz. The frequency automatically changes every 50 seconds. These signals are intended for reception by two groups of stations, each having distinct rescue functions. Direction-finding stations cooperating in long-range rescue operations normally use 8,364 kilohertz, whereas aircraft or ships locally engaged in search and rescue missions use 500 kilohertz.

Besides the automatic feature, you can key the transmitter manually on 500 kilohertz only. This is done by means of a push-button telegraph key.

Additional items (not shown) packaged with the transmitter include the antenna, a box kite, and balloons for supporting the antenna. Hydrogen-generating chemicals for inflating the balloon and a signal lamp that can be powered by the hand-crank generator are also included.

The equipment floats and is painted brilliant orange-yellow to provide good visibility against dark backgrounds.

A transceiver is shown in figure 5-15. It is portable, battery powered, and has two channels. It provides homing information and two-way voice communications between life rafts and searching ships and aircraft. This transceiver is a microminiature, solid-state, hand-held radio that operates on the 121.5-megahertz and the 243-megahertz guard channels. The transceiver has four operating controls. These are the volume (VOL) control, the two-position FREQUENCY SELECTOR, the PUSH-TO-TALK/ CODE button, and the three-position MODE switch.

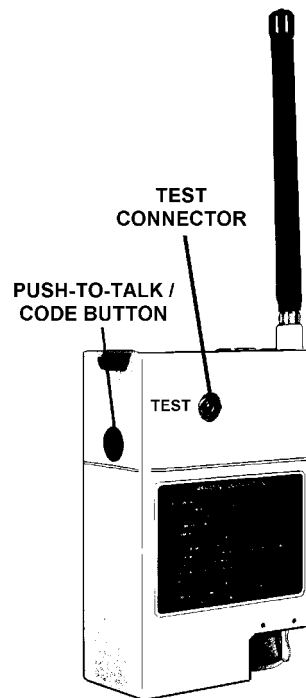

Figure 5-15.—Emergency portable transceiver.

The antenna is a rubber covered, omnidirectional, flexible whip antenna that is 7.74 inches long. The batteries supplied with the radio set are lithium D cells. Each cell is fused to protect against damage from external short circuits. Two cells are installed in the transceiver and four are packaged as spares.

OPERATIONAL EQUIPMENT

An operational transceiver is shown in figure 5-16. It is watertight, lightweight, portable, and operates in the vhf and uhf range. You can use any of 1,750 channels, spaced 200 kilohertz apart, in the 225-400 megahertz range. Its mode of operation is AM voice and it supplies an average output power of 3 watts. It was designed mainly for manpack (backpack) use, but it may also be used at a fixed station or in vehicles when certain accessories are added. When not in use, the equipment is disassembled and stowed in a special aluminum case similar to an ordinary suitcase.

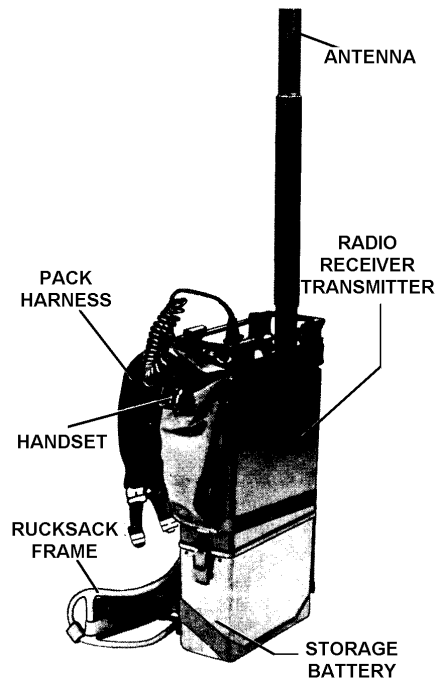

Figure 5-16.—Typical vhf/uhf backpack transceiver.

Figure 5-17 shows a typical vhf miniaturized manpack radio set. View A shows the pack frame, the handset, and the canvas accessory pouch. The pouch contains two antennas (one flexible steel band-type whip and one collapsible rigid whip). The handset fits in the pouch when not in use. View B shows the transmitter-receiver.

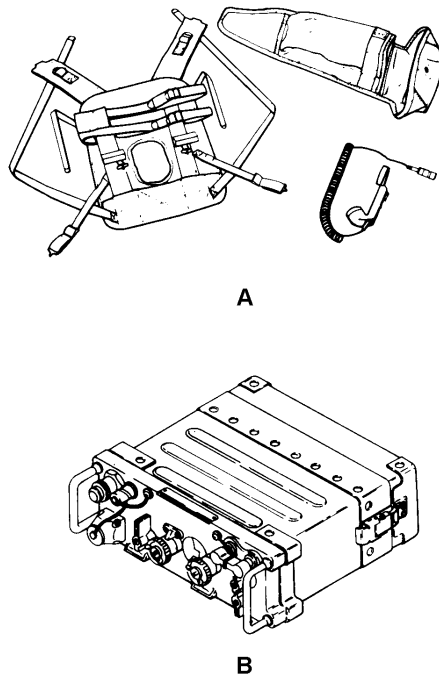

Figure 5-17.—Vhf receiver-transmitter.

Now that you have learned about portable equipment, let's look at one of the newest areas of communications. You are going to learn the fundamentals of how a laser works and how it may be used in the field of communications.

Q9. What are the three main design considerations of portable equipment?

LASERS

The word LASER is an acronym for light amplification by stimulated emission of radiation. The laser is widely used in industry, and experimental work is being done with it in communications. You will find a laser is similar to uhf and microwave power sources and could replace either of them in point-to-point communications.

THEORY OF OPERATION

Lasers take energy at (or near) the visible light spectrum and convert it to a very narrow and intense beam in the same region. A close relative of the laser is the light emitting diode (LED). The LED takes dc or low frequency ac power and converts the energy into visible light.

The principle of the laser is somewhat similar to that of a very high-Q cavity resonator. Chapter 1 of NEETS, Module 11, *Microwave Principles*, explains cavity resonators. The laser is shock-excited by a spark transmitter. This transmitter is called a spark transmitter because it uses the discharge of a capacitor through an inductor and a spark gap as a source of rf. While the input energy of the laser covers a wide band of frequencies, the output is on one frequency. Energy outputs of the laser are either INCOHERENT or COHERENT. For example, if you turn on a transmitter with no modulation, you will get coherent radiation. When you connect a noise source to an antenna, the result is incoherent radiation.

Lasers can be either cw or pulsed. Actually, lasers are little different from conventional oscillators. However, the way lasers convert energy from one form to another is quite different. In conventional oscillators, dc power from the collector is converted to rf energy. The frequency is for the most part independent of the molecular or atomic structure of the generator. This is not true for the laser. Laser conversion takes place directly within the molecular structure of a crystal or gas. The external circuits have little effect on actual output frequency. The fact that the light from an LED is always the same color results from similar conditions. In a laser, incoherent light excites the electrons in the atoms to higher energy levels than they normally would have. The new energy states are unstable and the electrons drop down to lower energy levels. Energy is then released in the form of light.

Figure 5-18 shows the ends of the crystal or glass tube laser with light waves reflecting back and forth between two mirrored surfaces. One mirror is only partially reflective, and light energy is transmitted through it to form the light beam. You will find that power sources for lasers include flash tubes or, in the case of diode-type lasers, dc power supplies.

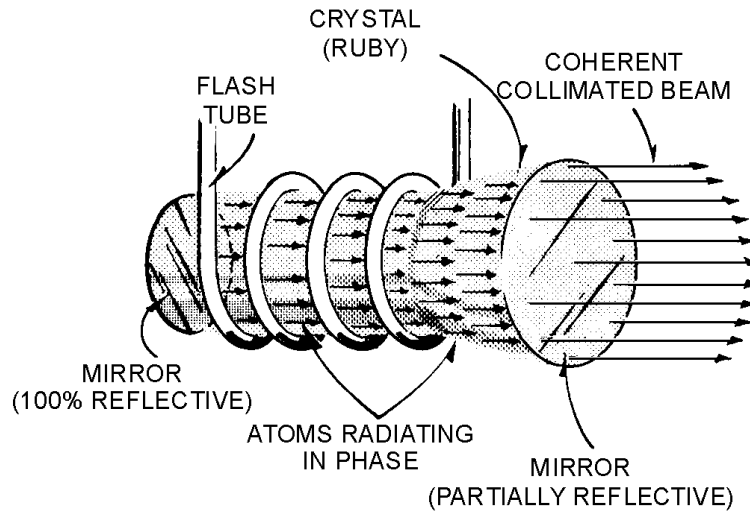

Figure 5-18.—Simple laser.

COMMUNICATIONS APPLICATIONS

High-energy lasers have very small power losses. As a result, a laser with a 2- or 3-inch initial beam can be used to communicate directly with a distant planet. However, from a communications standpoint, they do have some drawbacks. While laser energy is capable of being formed into a very narrow beam, it is still subject to the same difficulties as any other form of light transmission. Fog and other adverse weather conditions can absorb the light. Small atmospheric temperature variations can cause deflection and scattering. An optical waveguide was designed to help overcome this problem. It consists of a thin dielectric fiber clothed by another dielectric coating several wavelengths thick. It has been successfully used to move the beam over considerable distances and around bends. The use of optical waveguides is known as FIBER OPTICS. A number of fibers can be paralleled to reduce the attenuation through the waveguide. This technique has resulted in an inexpensive telephone system with a bandwidth greater than that of previous methods. Researchers are attempting to develop a laser that will operate in the blue-green portion of the visible spectrum. Water offers little attenuation to the blue-green band of frequencies. Because of this, blue-green communications lasers could possibly penetrate the ocean to great depths.

This could give us a very secure undersea communications link.

Q10. Lasers operate in what portion of the frequency spectrum?

Q11. What are the two types of lasers?

Q12. What are the effects of adverse weather on the laser beam?

SUMMARY

Now that you have completed this chapter, a review of what you have learned is in order. The following summary will refresh your memory of new terms.

DOUBLING UP is a type of two-equipment installation where one unit can be substituted for another in the event of failure.

FREQUENCY SYNTHESIZER is a frequency source of high accuracy.

DUMMY LOAD is a nonradiating device that absorbs the rf and has the impedance characteristics of the antenna.

HELIX HOUSE is a building at a transmitter site that contains antenna loading, coupling, and tuning circuits.

A **HELIX** is a large coil of wire. It acts as a coil and is used with variable inductors for impedance matching of high-power transmitters.

TOP-HAT antennas are center-fed and capacitively loaded.

TRIATIC is a special type of monopole antenna array.

LASER is an acronym for light amplification by stimulated emission of radiation.

COHERENT refers to radiation on one frequency or nearly so.

INCOHERENT refers to radiation on a broad band of frequencies.

FIBER OPTICS are conductors or optical waveguides that readily pass light.

MTDS is an abbreviation for the marine tactical data system.

AFDS is an abbreviation for the amphibious flagship data system.

ATDS is an abbreviation for the airborne tactical data system.

ASWTDS is an abbreviation for the antisubmarine warfare tactical data system.

ANSWERS TO QUESTIONS Q1. THROUGH Q12.

- A1. An impedance-matched device capable of absorbing all of a transmitters power.*
- A2. It demodulates ssb, cw, and fsk signals.*
- A3. 300 kilohertz to 3 megahertz.*
- A4. Troposphere.*
- A5. Up to 600 4-kilohertz channels.*
- A6. Up to 800 kilometers (500 statute miles).*
- A7. Speed.*
- A8. Links 4A, 11, and 14.*
- A9. They must be lightweight, compact, and self-contained.*
- A10. At or near visible light.*
- A11. Cw or pulsed.*
- A12. It absorbs it.*

APPENDIX I

GLOSSARY

ACTIVE SATELLITE—A satellite that amplifies the received signal and retransmits it back to earth.

AFDS—An abbreviation for the amphibious flagship data system.

ANGLE OF INCLINATION—The angular difference between the equatorial plane of the earth and the plane of orbit of the satellite.

ANTENNA COUPLER—A device used for impedance matching between an antenna and a transmitter or receiver.

APOGEE—The point in the orbit of a satellite the greatest distance from the earth.

ASSEMBLY—A number of parts or subassemblies, or any combination thereof, joined together to perform a specific function.

ASWTDS—An abbreviation for the antisubmarine warfare tactical data system.

ASYNCHRONOUS ORBIT—One where the satellite does not rotate or move at the same speed as the earth.

ATDS—An abbreviation for the airborne tactical data system.

AUDIO FREQUENCY TONE SHIFT—A system that uses amplitude modulation to change dc mark and space impulses into audio impulses.

AUTOMATIC TRACKING—Tracking done by the equipment comparing the direction of the antenna axis and the direction of the received signal.

AUTOMATIC VOLUME/GAIN CONTROL—A circuit used to limit variations in the output signal strength of a receiver.

BALANCED PHASE DETECTOR—A circuit that controls the oscillator frequency (afc).

BAUD—A measurement of speed based on the number of code elements or units per second.

BEAT-FREQUENCY OSCILLATOR—An additional oscillator used in a receiver when receiving a cw signal. It provides an audible tone.

BITS-PER-SECOND—Bit is an acronym of the words binary digit. One bit is equal to one signal unit or element.

BLACK—The reference color of equipment that passes unclassified information. It normally refers to patch panels.

CODE—In teletypewriter operation, code is a combination of mark and space conditions representing symbols, figures, or letters.

COHERENT—Radiation on one frequency.

COMPARATOR—An equipment that compares incoming signals and selects the strongest to be fed to a teletypewriter through a patch panel. This is used in diversity operation.

CONVERTER—An equipment that changes the audio output of a receiver to dc pulses. These pulses are fed to a tty to indicate marks and spaces.

DETECTION—The separation of low-frequency (audio) intelligence from the high (radio) frequency carrier.

DOUBLING UP—This is a type of two-equipment installation where one unit can be substituted for another in the event of failure.

DOWN LINK—The frequency used to transmit an amplified signal from the satellite back to earth.

DUMMY LOAD—A nonradiating device that absorbs the rf and has the impedance characteristics of the antenna.

ECLIPSE—This occurs when the satellite is not in view or in direct line of sight with the sun. This happens when the earth is between them.

ELECTROMAGNETIC INTERFERENCE—A term used to describe the degradation of a receiver or system.

EPHEMERIS—A table showing the precalculated position of a satellite at any given time.

EQUATORIAL ORBIT—An orbit that occurs when the plane of a satellite coincides with the plane of the earth at the equator.

EXTREMELY HIGH FREQUENCY—The band of frequencies from 30 gigahertz to 300 gigahertz.

EXTREMELY LOW FREQUENCY—The band of frequencies up to 300 hertz.

FACSIMILE—The method for transmitting and receiving still images. These images can be maps, photographs, and handwritten or printed text.

FADING—The variations in signal strength at the antenna of a receiver.

FIBER OPTICS—Conductors or optical waveguides that readily pass light.

FIDELITY—The ability of a receiver to accurately reproduce, at its output, the signal at its input.

FORWARD AGC—The type of agc that causes an amplifier to be driven towards saturation.

FRAMING—The process of synchronizing a facsimile receiver to a transmitter. This allows proper picture reproduction.

FREQUENCY-DIVISION MULTIPLEXING—Multiplexing that transmits and receives the full 360 degrees of each sine wave.

FREQUENCY SYNTHESIS—A process that uses heterodyning and frequency selection to produce a signal.

FREQUENCY SYNTHESIZER—A frequency source of high accuracy.

GANGED TUNING—The process used to tune two or more circuits with a single control.

GROUP—A collection of units, assemblies, subassemblies, and parts. It is a subdivision of a set or system but is not capable of performing a complete operational function.

HAND OVER—The operation where one earth terminal yields control to another as a satellite moves out of its area of coverage.

HARMONIC—An exact multiple of the fundamental frequency. Even harmonics are 2, 4, and so on, times the fundamental. Odd are 3, 5, and so on, times the fundamental frequency.

HELIX—A large coil of wire. It acts as a coil and is used with variable inductors for impedance matching of high-power transmitters.

HELIX HOUSE—A building at a transmitter site that contains antenna loading, coupling, and tuning circuits.

HETERODYNING—The mixing of the incoming signal with the local oscillator frequency. This produces the two fundamentals and the sum and difference frequencies.

HIGH FREQUENCY—The band of frequencies from 3 megahertz to 30 megahertz.

IMAGE FREQUENCY—An undesired frequency capable of producing the desired frequency through heterodyning.

INCLINED ORBIT—Orbits where there is some amount of inclination. These include equatorial and polar orbits.

INCOHERENT—This refers to radiation on a broad band of frequencies.

INTELLIGENCE—Any signal that conveys information (voice, teletypewriter, facsimile).

KEYER—A device that changes dc pulses to mark and space modulation for teletypewriter transmissions.

LASER—An acronym for light amplification by stimulated emission of radiation.

LISSAJOUS PATTERN—A combined, simultaneous display of the amplitude and phase relationships of two input signals on a CRT.

LOW FREQUENCY—The band of frequencies from 30 kilohertz to 300 kilohertz.

MARKING—The state where a circuit is closed and current flows in teletypewriter operation.

MEDIUM ALTITUDE ORBIT—An orbit from 2,000 to 12,000 miles above the earth. The rotation rate of the earth and satellite are quite different, and the satellite moves quickly across the sky.

MEDIUM FREQUENCY—The band of frequencies from 300 kilohertz to 3 megahertz.

MTDS—An abbreviation for the marine tactical data system.

MULTICOUPLERS—Couplers patch receivers or transmitters to antennas. They also filter out harmonics and spurious responses, and impedance-match the equipment.

MULTIPLEXING—A method for simultaneous transmission of two or more signals over a common carrier wave.

NEAR SYNCHRONOUS ORBIT—An orbit in which the satellite rotates close to but not exactly at the same speed as the earth.

NEUTRAL—The teletypewriter operation where current flow represents a mark and no flow represents a space.

NOISE SILENCER, NOISE SUPPRESSOR, OR NOISE LIMITER—Circuits that clip the peaks of the noise spikes in a receiver.

NONSYNCHRONOUS—The teletypewriter operation where both transmitter and receiver do not operate continuously

ORDER-WIRE CIRCUIT—A circuit between operators used for operations control and coordination.

PAGE PRINTER—A high-speed printer that prints teletypewriter characters one at a time in a full-page format.

PASSIVE SATELLITE—A satellite that reflects radio signals back to earth.

PATCH PANEL—A panel used to tie a receiver or transmitter to its associated equipment.

PART—A part is one component or two or more components joined together. It is not normally subject to disassembly without destruction.

PERFORATOR—A device that stores a teletypewriter message on a paper tape. It may be stored for later transmission.

PERIGEE—The point in the orbit of a satellite closest to the earth.

PERMANENT MAGNET SPEAKER—A speaker with a permanent magnet mounted on soft iron pole pieces.

POLAR—The teletypewriter operation where current flow of one polarity represents a mark and current of the opposite polarity represents a space.

POLAR ORBIT—An orbit that has an angle of inclination of or near 90 degrees.

PROGRAMMED TRACKING—The method that uses known satellite orbital parameters to generate antenna pointing angles.

RADIO COMMUNICATIONS—The term describing teletypewriter, voice, telegraphic, and facsimile communications.

RADIO FREQUENCY CARRIER SHIFT—The system that uses a keyer to shift a radio frequency signal above or below an assigned frequency. These shifts correspond to marks and spaces.

RADIO SET CONTROL UNIT—Equipment used to remotely control certain transmitter and receiver functions.

RECEIVER—Equipment that converts electromagnetic energy into a visible or an audible form.

RECEIVER TRANSFER SWITCHBOARD—Equipment used to transfer receiver audio outputs to remote control station audio circuits.

RECEPTION—The instant when an electromagnetic wave passes through a receiver antenna and induces a voltage in that antenna.

RED—The reference color of equipment that passes classified information. It normally refers to patch panels.

REPEATER—Another name for an active satellite.

REPERFORATOR—Equipment that converts the incoming tty signal and stores it on paper tape.

REPRODUCTION—The process of converting electrical signals to sound waves. This sound is speech, music, and so on.

REVERSE AGC—The type of agc that causes an amplifier to be driven toward cut-off.

RUNNING OPEN—The teletypewriter condition where the type hammer constantly strikes the type box but does not print or move across the page.

SATELLITE ECLIPSE—An eclipse where the rays of the sun don't reach the satellite. This prevents recharging of the solar cells of the satellite and decreases the power to the transmitter.

SATELLITE-SUN CONJUNCTION—A period when the satellite and sun are close together and the noise from the sun prevents or hampers communications.

SCANNING—The process of subdividing a picture in an orderly manner into segments. This is used in facsimile transmission.

SELECTIVITY—The ability of a receiver to select the desired signal and reject unwanted signals.

SENSITIVITY—The ability of a receiver to reproduce very weak signals. The greater the receiver sensitivity, the weaker the signal that will be reproduced.

SET—A unit or units and the assemblies, subassemblies, and parts connected or associated together to perform a specific function.

SPACING—The condition in teletypewriter operation where a circuit is open and no current flows.

SQUELCH—A circuit that cuts off the output of a receiver when there is no input.

START—The first unit of a teletypewriter signal. It is always a space.

STOP—The last unit of a teletypewriter signal. It is always a mark.

SUBASSEMBLY—Consists of two or more parts that form a portion of an assembly or a unit.

SUBHARMONIC—An exact submultiple of the fundamental frequency. Even subharmonics are one-half, one-quarter, and so on. Odd subharmonics are one-third, one-fifth, and so on of the fundamental frequency.

SUPERHIGH FREQUENCY—The band of frequencies from 3 gigahertz to 30 gigahertz.

SUPPRESSION—The process of eliminating an undesired portion of a signal.

SYNCHRONOUS—A type of teletypewriter operation where both transmitter and receiver operate continuously.

SYNCHRONOUS ORBIT—An orbit in which the satellite moves or rotates at the same speed as the earth.

SYSTEM—A combination of sets, units, assemblies, subassemblies, and parts joined together to form a specific operational function or several functions.

TELECOMMUNICATIONS—The transmission, emission, or reception of signs, signals, writings, images, or sounds. This is done by visual, oral, wire, radio, or other electromagnetic means.

TELETYPEWRITER—A machine that can transmit and or receive letters, numbers, or symbols. It may have a keyboard similar to a typewriter.

TEMPEST—A term normally used to describe compromising emanations. These emanations are unintentionally radiated signals that could disclose classified information.

TIME-DIVISION MULTIPLEXING—The process that periodically samples the full 360 degrees of each sine wave. The sample can be of a received signal or of a signal to be transmitted.

TONE-TERMINAL SET—Equipment that converts tty dc pulses into audio tones for modulation of a transmitter in audio-frequency-tone shift transmissions.

TOP-HAT—An antenna that is center-fed and capacitively loaded.

TRANSITION—The time it takes to shift from a mark to a space condition or from a space to a mark condition.

TRANSMITTER—Equipment that generates and amplifies an rf carrier, modulates the rf carrier with intelligence, and radiates the signal into space.

TRANSMITTER DISTRIBUTOR—A device that reads Baudot code from paper tape and allows a message to be printed on a page printer.

TRANSMITTER TRANSFER SWITCHBOARD—Equipment that selectively transfers remote control station functions and signals to transmitters.

TRIATIC—A special type of monopole antenna array.

ULTRAHIGH FREQUENCY—The band of frequencies from 300 megahertz to 3 gigahertz.

UNIT—An assembly or any combination of parts, subassemblies, and assemblies mounted together. Normally capable of independent operation.

UP LINK—The frequency used to transmit a signal from earth to a satellite.

VERY HIGH FREQUENCY—The band of frequencies from 30 megahertz to 300 megahertz.

VERY LOW FREQUENCY—The band of frequencies from 3 kilohertz to 30 kilohertz.

WORDS-PER-MINUTE—An approximate rate of speed. It means the number of five letter words with a space between them that can be transmitted or received in a one-minute period.

ZONE OF MUTUAL VISIBILITY—The area where the satellite can be seen by both the up- and down-link earth terminals.

APPENDIX II

REFERENCE LIST

CHAPTER ONE

- ELF Communications System Program*, NAVEXINST 5430.26, October 1983.
- Shipboard Electronics Materials Officer*, NAVEDTRA 10478-A, 1982.
- Electronics Technician, 3 & 2*, Vol. 3, NAVEDTRA 10198, 1979.
- Cryptologic Technician M 3 & 2*, NAVEDTRA 10232-C, 1978.
- Radioman 3 & 2*, NAVEDTRA 10228-G, 1978.
- Howeth, L. S., *History of Communications-Electronics in the United States Navy*, Bureau of Ships and Office of Naval History, Washington, D.C., 1963.

CHAPTER TWO

- Electronics Technician 3 & 2*, Vol. 3, NAVEDTRA 10198, 1979.
- Cryptologic Technician M 3 & 2*, NAVEDTRA 10232-C, 1978.
- Radioman 3 & 2*, NAVEDTRA 10228-G, 1978.
- Cryptologic Collection Equipments*, NAVEDTRA 10251, 1977.
- Basic Electronics*, Vol. 1, NAVPERS 10087-C, 1970.
- Basic Electronics*, Vol. 2, NAVPERS 10087-C1, 1979.
- Fundamentals of Single Sideband*, NAVEX 0967-LP-222-2010, 1958.

CHAPTER THREE

- Shipboard Electronics Material Officer*, NAVEDTRA 10478-A, 1982.
- Electronics Technician 3 & 2*, Vol. 3, NAVEDTRA 10198, 1979.
- Cryptologic Technician M 3 & 2*, NAVEDTRA 10232-C, 1978.
- The Electronics Material Officer's Guide to Shipboard Electromagnetic Interference Control*, NAVSEASYS COM STD-407-5287556, 1983.

CHAPTER FOUR

Shipboard Electronics Material Officer, NAVEDTRA 10478-A, 1982.

Electronics Technician 3 & 2, Vol. 3, NAVEDTRA 10198, 1979.

Cryptologic Technician M 3 & 2, NAVEDTRA 10232-C, 1978.

Radioman 3 & 2, NAVEDTRA 10228-G, 1978.

Satellite Communications Systems, United States Air Force, KEO-90008, 1972.

Fleet Satellite Communications System Description, Naval Ocean Systems Center, January 1978.

CHAPTER FIVE

Shipboard Electronics Material Officer, NAVEDTRA 10478-A, 1982.

Electronics Technician 3 & 2, Vol. 3, NAVEDTRA 10198, 1979.

Microwave and Tropo-Scatter Communications Systems, NAVELEX 0101,112, 1972.

Vlf, Lf and Mf Communications Systems, NAVELEX 0101,113, 1972.

Design Handbook for Optical Fiber Systems, U.S. Army Communications-Electronics,
CCC-CED-XES-78-01, 1978.

Cooper, Robert S., "SPACE Another Dimension of Defense," *Defense 84*, August 1984, pp.
12-19.

McGraw-Hill, Vol. 3, *Encyclopedia of Science and Technology*, 1971.

McGraw-Hill, Vol. 12, *Encyclopedia of Science and Technology*, 1971.

MODULE 17 INDEX

A

Amplitude modulation (AM) receiver, 2-11
Amplitude modulated transmitter, 2-3 to 2-4
Angle of inclination, 4-4
Antenna coupler group, 3-7 to 3-8
Antenna distribution systems, 3-11 to 3-15
Apogee, 4-3
Assembly, 1-8
Audio frequency tone shift (afts), 3-21 to 3-22, 3-29
Audio reproduction devices, 2-30 to 2-32
Audio tone, 2-25 to 2-26
Automatic digital network (AUTODIN), 1-17
Automatic frequency control (afc), 2-27 to 2-29
Automatic secure voice communications (AUTOSEVOCOM), 1-17
Automatic tracking, 4-14
Automatic voice network (AUTOVON), 1-17

B

Balanced-phase detector, 2-28
Basic principles, teletypewriter and facsimile equipment, 3-15 to 3-19
Basic systems, teletypewriter and facsimile equipment, 3-14 to 3-34
Beat frequency oscillator (bfo), 2-23
Broadcast, 1-16

C

Carrier reinsertion, 2-16
Communications satellite system, description of, 4-3 to 4-4
Communications applications, lasers, 5-18
Communications fundamentals, 1-15 to 1-18
Communications links, 1-15 to 1-16
Communications theory, introduction to, 2-1 to 2-37
Continuous wave transmitter, 2-2 to 2-3
Cryptographic equipment, 3-26
Crystal filters, 2-26

D

Defense Communications Satellite Program (DCSP), 4-2
Defense Satellite Communications System (DSCS) phase II, 4-2
Defense special security communications system (DSSCS), 1-18
Delayed automatic gain control (dagc), 2-22
Detection, 2-12
Dummy load, 5-3

E

Earth terminal characteristics, 4-9
Electrical telecommunications, 1-2 to 1-4
 facsimile, 1-3
 radiotelegraph, 1-2
 radiotelephone, 1-2
 teletypewriter, 1-3
Electromagnetic compatibility, 3-38
Electromagnetic interference, 3-38 to 3-39
Electromagnetic radiation, 3-40 to 3-43
Emergency equipment, 5-14 to 5-15
Equatorial orbit, 4-5
Equipment purposes, 3-1 to 3-15
Extremely low frequency (elf), 1-11

F

Facsimile (fax), 1-3, 3-35 to 3-36
Fiber optics, 5-18
Fidelity, 2-11
Fleet broadcasts, 1-14
Forward agc, 2-21
Frequency modulated (fm) receiver, 2-12 to 2-14
Frequency multiplication, 2-6
Frequency synthesis, 2-29
Full Duplex, 1-16
Fundamental satellite communications system, 4-2 to 4-15

Fundamental systems equipment, 3-1 to 3-47
equipment purposes, 3-1 to 3-15
antenna distribution systems, 3-11 to 3-15
handset, 3-2
radio set control unit, 3-2 to 3-3
receivers, 3-10
transfer switchboards, 3-3 to 3-4
transmitters, 3-4 to 3-10
security, quality monitoring, and safety, 3-36 to 3-43
electromagnetic radiation, 3-40 to 3-43
shipboard communications systems
quality monitoring (QMCS), 3-38 to 3-43
TEMPEST, 3-36
transmission security, 3-37
summary, 3-43 to 3-47
teletypewriter and facsimile equipment, 3-15 to 3-34
basic principles, 3-15 to 3-19
basic systems, 3-14 to 3-34
Future satellite communications, 4-17 to 4-19

G

Glossary, AI-1 to AI-6
Ground-to-air, 1-14
Group, 1-7

H

Half duplex, 1-15
Handset, 3-2
Harmonics, 2-5
Helix, 5-3 to 5-4
Heterodyning, 2-12
High command communications network (HICOM), 1-18
High frequency (hf), 1-13
History of satellite communications, 4-1 to 4-2

I

Image signals, 2-14

Inclined orbit, 4-4
Introduction to communications theory, 2-1 to 2-37
introduction, 2-1
receiver fundamentals, 2-9 to 2-30
audio reproduction devices, 2-30 to 2-32
frequency synthesis, 2-29
receiver characteristics, 2-10
receiver control circuits, 2-16 to 2-29
single-sideband, 2-14 to 2-16
superheterodyne receiver, 2-11 to 2-16
summary, 2-32 to 2-37
transmitter fundamentals, 2-3 to 2-9
amplitude modulated transmitter, 2-3 to 2-4
continuous wave transmitter, 2-2 to 2-3
frequency modulated transmitter, 2-4 to 2-5
single-sideband transmitter, 2-7 to 2-9
Introduction to miscellaneous communications systems and equipment, 5-1 to 5-20
introduction, 5-1
lasers, 5-17 to 5-18
communications applications, 5-18
theory of operation, 5-17
portable equipment, 5-13 to 5-17
emergency equipment, 5-14 to 5-15
operational equipment, 5-15 to 5-17
summary, 5-19 to 5-20
systems, 5-1 to 5-13
medium frequency and below, 5-2 to 5-8
microwave, 5-8 to 5-10
naval tactical data system, 5-10 to 5-13
Introduction to radio-frequency communications, 1-1 to 1-20
communications fundamentals, 1-15 to 1-18
communications links, 1-15 to 1-16
Navy-only networks, 1-18
switched networks, 1-16 to 1-18
introduction to naval telecommunications, 1-1 to 1-15

Introduction to radio-frequency communications—Continued
 electrical, 1-2 to 1-3
 Navy frequency band use, 1-10 to 1-13
 system introduction, 1-4 to 1-10
Introduction to satellite communications, 4-1 to 4-21
 fundamental satellite communications system, 4-2 to 4-15
 description of communications satellite system, 4-3 to 4-6
 earth terminal characteristics, 4-9 to 4-10
 satellite acquisition and tracking, 4-13 to 4-15
 satellite characteristics, 4-6 to 4-9
 shipboard receive-only equipment systems, 4-12
 history of satellite communications, 4-1 to 4-2
 Defense Communications Satellite Program (DCSP), 4-2
 role of satellite communications, 4-15 to 4-19
 advantages of satellite communications, 4-15
 future satellite communications, 4-17 to 4-19
 satellite limitations, 4-16
 summary, 4-19 to 4-21

L

Lasers, 5-16 to 5-17
Learning objectives, 1-1, 2-1, 3-1, 4-1, 5-1
Line-of-sight system, 5-8
Links, 5-12 to 5-13
Low frequency (lf), 1-12

M

Manual gain control (mgc), 2-16 to 2-17
Manual volume control (mvc), 2-17
Medium frequency (mf), 1-12
Medium frequency and below, 5-2 to 5-8
Microwave, 5-8 to 5-10

Modes of operation, 1-15
Modulation rate, 3-18
Multicoupler, 3-13 to 3-14
Multiplexing, 2-9, 3-30 to 3-34

N

Naval tactical data system, 5-10 to 5-13
Naval telecommunications, introduction to, 1-1 to 1-15
Navy frequency band use, 1-10 to 1-13
Navy-only networks, 1-18
Navy operational radio and telephone switchboard (NORATS), 1-18
Noise, 2-10
Noise silencer/suppressor/limiter, 2-23

O

Operational equipment, 5-15 to 5-17
Orbits descriptions, 4-3 to 4-6
Order-wire circuit, 2-9

P

Part, 1-9
Patch panels, 3-25
Perigee, 4-3
Permanent magnet speaker, 2-30
Phase discriminator, 2-28
Point-to-point, 1-13
Portable equipment, 5-13 to 5-17
Programmed tracking, 4-14

R

Radio set control unit, 3-2 to 3-3
Radio frequency amplifier, 3-6
Radio-frequency-carrier shift (rfcs), 3-22 to 3-24
Radio-frequency communications, introduction to, 1-1 to 1-20
Radiotelegraph, 1-2
Radiotelephone, 1-2
Receive multicoupler, 3-13
Receiver characteristics, 2-10
Receiver control circuits, 2-16 to 2-29

Receiver fundamentals, 2-9 to 2-30
Receivers, 3-10
Reception, 2-10
Reference designations, 1-9 to 1-10
Reference list, AII-1 to AII-2
Reproduction, 2-10
Reverse age, 2-22
Role of satellite communications, 4-15 to 4-19

S

Satellite acquisition and tracking, 4-13 to 4-15
Satellite characteristics, 4-6 to 4-9
Satellite communications, introduction to, 4-1 to 4-21
Satellite limitations, 4-16
Security, quality monitoring, and safety, 3-36 to 3-43
Selectivity, 2-10
Selection, 2-10
Semiduplex, 1-15
Sensitivity, 2-10
Set, 1-7
Shipboard communications systems quality monitoring (QMCS), 3-38 to 3-43
Shipboard receive-only equipment systems, 4-12
Ship-to-ship, 2-9
Ship-to-shore, 1-14
Simplex, 1-15
Single-sideband, 2-14 to 2-16
Single-sideband transmitter, 2-7 to 2-9
Squelch, 2-23
Strategic, 1-15
Subassembly, 1-8
Subharmonic, 2-5
Superheterodyne receiver, 2-11 to 2-16
Suppressed carrier, 2-7
Suppression, 2-7

Switched networks, 1-16 to 1-17
System, 1-5 to 1-6
System introduction, 1-4 to 1-10
Systems, 5-1 to 5-13

T

Tactical, 1-15
Teletypewriter, 1-3
Teletypewriter and facsimile equipment, 3-15 to 3-34
TEMPEST, 3-36
Theory of operation, lasers, 5-17
Transfer switchboards, 3-3 to 3-4
Transmission security, 3-37
Transmit multicoupler, 3-14
Transmitter fundamentals, 2-3 to 2-9
Transmitters, 3-4 to 3-10
Triatic antenna, 5-4
Tropospheric scatter system, 5-9 to 5-10

U

Unit, 1-7

V

Very high frequency (vhf), 1-14
Very low frequency (vlf), 1-11

Assignment Questions

Information: The text pages that you are to study are provided at the beginning of the assignment questions.

ASSIGNMENT 1

Textbook assignment: Chapter 1, "Introduction to Radio-Frequency Communications," pages 1-1 through 1-20. Chapter 2, "Introduction to Communications Theory," pages 2-1 through 2-37.

- 1-1. For naval communications to be effective, all involved must be top performers. Reliable, secure, and timely receiving and transmitting of information is the goal. Which of the following requirement standards are used to determine whether or not this goal has been met?
1. Wartime
 2. Peacetime
 3. Cold war less 10 percent
 4. Nuclear war less 25 percent
- 1-2. What are the two types of electrical communications?
1. Radio and wire
 2. Television and wire
 3. Telegraph and radio
 4. Television and radio
- 1-3. Which of the following terms includes intelligence produced by wire, radio, visual means, oral means or electromagnetic systems?
1. Telecommunications
 2. Radiotelegraph
 3. Electrolysis
 4. Photocopy
- 1-4. Radiotelegraph (cw) is valuable when communicating to, from, and among widely separated naval units. What is the main advantage of the cw mode?
1. Cost
 2. Speed
 3. Security
 4. Reliability
- 1-5. Tactical communications is usually considered as line-of-sight. What maximum distance is normally within the line-of-sight range?
1. 5 miles
 2. 25 miles
 3. 50 miles
 4. 250 miles
- 1-6. You want to transmit high-speed automatic page or tape copy across an ocean area. Which of the following methods should you choose?
1. Facsimile
 2. Radiotelegraph
 3. Radiotelephone
 4. Radioteletypewriter
- 1-7. What method is normally used to transmit graphs electronically?
1. Facsimile
 2. Radio teletypewriter
 3. Frequency-shift keying
 4. Audio-frequency-tone shifting
- 1-8. When you use subdivisions to assign reference designators to equipment, what is the designator of (a) the largest and (b) the smallest?
1. (a) System (b) set
 2. (a) Set (b) unit
 3. (a) Unit (b) assembly
 4. (a) System (b) part

- 1-9. When using the reference designator 1A6A4J6, what level does the number 1 refer to?
1. Subassembly
 2. Assembly
 3. Group
 4. Unit
- 1-10. What is the total number of frequency bands the military is currently using for communications?
1. 5
 2. 7
 3. 9
 4. 11
- 1-11. Extremely low-frequency transmissions are primarily directed at which of the following users?
1. Shore installations
 2. Surface ships
 3. Submarines
 4. Aircraft
- 1-12. Vlf transmitters are used primarily for which of the following purposes?
1. Navigation and fleet communications
 2. Frequency standards and time signals
 3. Astronomy and oscillator calibration
 4. Aircraft control and space vehicle tracking
- 1-13. Navy use of the low-frequency band is mainly for which, if any, of the following broadcasts?
1. Ship to shore
 2. Fleet multichannel
 3. Space vehicle telemetry
 4. None of the above
- 1-14. For which of the following reasons does the Navy use only the upper and lower ends of the mf band?
1. They are the most reliable
 2. They produce the best propagation
 3. The commercial fm band occupies the middle
 4. The commercial AM band occupies the middle
- 1-15. Hf communications over long-distance trunks, or links between fixed terminals are examples of which of the following types of systems?
1. Fleet broadcast
 2. Point-to-point
 3. Ground-to-air
 4. Ship-to-shore
- 1-16. Sending a message on several frequencies at once is an example of which of the following transmission types?
1. Time-diversity
 2. Phase-diversity
 3. Distance-diversity
 4. Frequency-diversity
- 1-17. What type of diversity uses physically separated transmit or receive antennas to improve communications?
1. Time
 2. Phase
 3. Space
 4. Frequency
- 1-18. Normally the transmission range of vhf is limited to line of sight. What technique is used to increase this range?
1. Tropospheric scatter
 2. Atmospheric diversity
 3. Ionospheric maneuvering
 4. Each of the above

- 1-19. A complex of links make up a major communications system. The naval communications system is further broken down into what two groups?
1. Strategic and local
 2. World-wide and local
 3. Strategic and tactical
 4. Tactical and world-wide
- 1-20. Communications links have many modes of operation. One terminal in a link has its equipment setup in simplex. The other terminal is using two channels or frequencies in a configuration that allows sending and receiving of different messages at the same time. These two terminals working together make up what mode of operation?
1. Full duplex
 2. Half duplex
 3. Quasiduplex
 4. Semiduplex
- 1-21. What communications link mode of operation provides telecommunications capability between stations at the same time in both directions?
1. Half duplex
 2. Semiduplex
 3. Broadcast
 4. Duplex
- 1-22. Aid in restoring downed fleet communications channels is furnished on a not-to-interfere basis by which of the following networks?
1. AUTOSEVOCOM
 2. NORATS
 3. HICOM
 4. DSSCS
- 1-23. Which of the following switched networks extends tactical voice to shore-based operational commands?
1. NORATS
 2. AUTOVON
 3. AUTODIN
 4. AUTOSEVOCOM
- 1-24. Of the following transmitter types, which are used for basic communications?
1. Cw, AM, fm, and ssb
 2. Fsk, cw, AM, and tty
 3. Cw, ssb, voice and fm
 4. Voice, tty, fsk, and AM
- 1-25. Cw transmissions have narrow bandwidths and a high degree of intelligibility under severe noise conditions. What is the primary Navy use for cw?
1. Radioteletypewriter
 2. Radiotelegraphy
 3. Facsimile
 4. Voice
- 1-26. A cw transmitter must contain which of the following components?
1. A traveling-wave tube
 2. A demodulator
 3. A combiner
 4. A keyer
- 1-27. In a cw transmitter, a buffer stage performs which of the following functions?
1. Current divider
 2. Voltage divider
 3. Current amplifier
 4. Voltage amplifier

- 1-28. There are differences between low- and high-power transmitters. The main difference is the high power transmitter contains a larger number of which of the following types of amplifiers?
1. Oscillator
 2. Final power
 3. Intermediate power
 4. Intermediate frequency
- 1-29. In an AM transmitter, audio frequencies are converted into corresponding electrical energy by which of the following components?
1. An oscillator
 2. A microphone
 3. A modulator
 4. A headset
- 1-30. In an fm transmitter, a varicap performs which of the following functions?
1. It amplifies the outgoing signal
 2. It varies the oscillator frequency
 3. It demodulates the outgoing signal
 4. It multiplies the oscillator frequency
- 1-31. If an oscillator has a fundamental frequency of 3,550 megahertz, what is the frequency of the third harmonic?
1. 5,325 megahertz
 2. 7,100 megahertz
 3. 9,875 megahertz
 4. 10,650 megahertz
- 1-32. If the fundamental frequency of an rf carrier is 1,000 kilohertz, what is the frequency of the fourth subharmonic?
1. 500 kilohertz
 2. 333 kilohertz
 3. 250 kilohertz
 4. 200 kilohertz
- 1-33. Oscillator output frequencies are raised to usable values by frequency multipliers. To raise an oscillator frequency from 20 megahertz to 120 megahertz, what combination of frequency multipliers would be used?
1. Two doublers
 2. A doubler and a tripler
 3. A doubler and a quadruplet
 4. A tripler and a quadruplet
- 1-34. When an AM signal leaves the antenna of a transmitter, which of the following frequency components does the signal contain?
1. The carrier
 2. The upper sideband
 3. The lower sideband
 4. All of the above
- 1-35. In a single-sideband transmitter, selection of the desired sideband and suppression of the other is done by which of the following components?
1. Mixer
 2. Filter
 3. Detector
 4. Oscillator
- 1-36. When compared to a conventional AM signal, an ssb signal provides which of the following advantages?
1. Improved frequency stability
 2. Increased receiver gain
 3. Reduced distortion
 4. Reduced bandwidth
- 1-37. For ship-to-shore teletypewriter circuits, which of the following types of multiplexing is/are used?
1. Time and/or phase
 2. Time and/or frequency
 3. Phase and/or modulation
 4. Frequency and/or modulation

- 1-38. Operators of transmitters and receivers use a circuit to coordinate the service of messages and to make frequency changes. What is the name of this circuit?
1. Order-wire circuit
 2. Documentation circuit
 3. Synchronization circuit
 4. Operator-eyes-only circuit
- 1-39. A transmitted electromagnetic wave enters an antenna, induces a voltage into it, and passes that voltage to a receiver. What is this chain of events called?
1. Reproduction
 2. Selection
 3. Detection
 4. Reception
- 1-40. When a receiver picks one frequency out from all other frequencies, it's performing which of the following basic functions?
1. Selection
 2. Reception
 3. Detection
 4. Reproduction
- 1-41. When a receiver separates the audio frequencies from the radio-frequency carrier it is performing which of the following basic functions?
1. Reception
 2. Selection
 3. Detection
 4. Reproduction
- 1-42. The receiver action of converting electrical energy to a usable format, such as sound, is an example of which of the following basic functions?
1. Reception
 2. Selection
 3. Detection
 4. Reproduction
- 1-43. Which of the following measurements provides an indication of the ability of a receiver to reproduce weak signals?
1. Bandwidth
 2. Sensitivity
 3. Selectivity
 4. Frequency response
- 1-44. Overall sensitivity of a receiver is limited by which of the following factors?
1. Noise
 2. Bandwidth
 3. Output power
 4. Frequency response
- 1-45. How is a receiver's ability to reject unwanted signals and receive desired signals determined?
1. Noise
 2. Fidelity
 3. Selectivity
 4. Sensitivity
- 1-46. When high fidelity is your prime consideration you should select a receiver that has been designed with which of the following features?
1. High gain
 2. High output power
 3. Broadband frequency selection circuits
 4. Narrowband frequency selection circuits
- 1-47. The IF frequency in a receiver is produced by which of the following methods?
1. Modulation
 2. Heterodyning
 3. Frequency synthesis
 4. Frequency multiplication

- 1-48. The process of heterodyning takes place in which of the following receiver circuits?
1. Mixer
 2. Comparator
 3. Oscillator
 4. Second IF amplifier
- 1-49. Of the following frequencies, which one is a typical value of IF for AM communications receivers?
1. 455 kilohertz
 2. 554 kilohertz
 3. 455 megahertz
 4. 554 megahertz
- 1-50. Two or more circuits within a receiver are varied by a single control through the use of which of the following processes?
1. Ganged tuning
 2. Frequency synthesis
 3. Automatic gain control
 4. Automatic frequency control
- 1-51. There are electrical differences between AM and fm receivers. An fm receiver contains which of the following circuits?
1. Comparator
 2. Discriminator
 3. Limiter
 4. Both 2 and 3 above
- 1-52. An fm signal has which of the following characteristics when compared to an AM signal?
1. More noise
 2. Less static
 3. A higher power output
 4. A lower operating frequency
- 1-53. Ssb transmissions have which of the following characteristics when compared to AM transmissions?
1. Wide bandpass frequencies
 2. Concentrated power
 3. Less modulation
 4. High fidelity
- 1-54. Single sideband receivers use a special oscillator. The output of that oscillator is fed directly to the detector circuit. What type of oscillator is used?
1. Local
 2. High frequency
 3. Variable frequency
 4. Carrier reinsertion
- 1-55. A transmitter has a suppressed carrier frequency of 4 megahertz and is radiating only an upper sideband signal. When the intelligence is a 1-kilohertz tone, which of the following sideband frequencies will be transmitted?
1. 3,999 kilohertz
 2. 4,000 kilohertz
 3. 4,001 kilohertz
 4. Both 2 and 3 above
- 1-56. Manual gain lets you adjust a receiver for maximum sensitivity and amplify weak input signals. Which of the following internal sections of the receiver are varied by this control?
1. Oscillator
 2. Audio frequency
 3. Radio frequency
 4. Intermediate frequency
- 1-57. Manual volume control of a receiver internally varies the input to which of the following circuits?
1. Detector
 2. Audio amplifier
 3. Frequency converter
 4. Radio frequency amplifier

1-58. Changes in receiver input strength due to changing atmospheric conditions is described by which of the following terms?

1. Gain
2. Fading
3. Ducting
4. Trapping

1-59. The rf amplifier connected to your receiving antenna has a voltage gain of 240. When the antenna is receiving a signal of 8 microvolts, what will be the maximum output voltage of the rf amplifier?

1. 1.92 millivolts
2. 2.91 microvolts
3. 30 microvolts
4. 33 millivolts

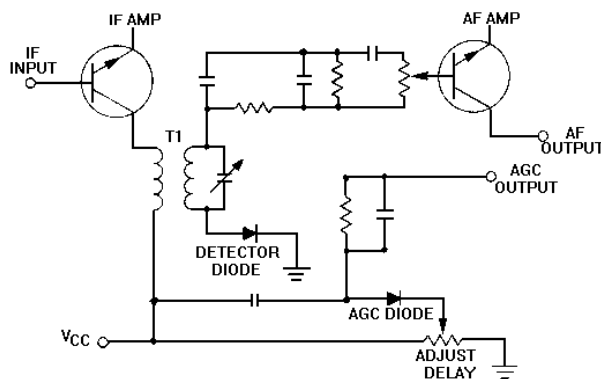

Figure 1A.

IN ANSWERING QUESTIONS 1-60 AND 1-61, REFER TO FIGURE 1A.

1-60. If the agc diode shorts, which of the following actions would result?

1. There would be no agc
2. There would be no delay
3. The agc diode would be reverse biased
4. The polarity of the agc would be reversed

1-61. The amount of agc feedback depends on attaining an established received signal strength. If the established signal strength is set for 50 microvolts, and the input signal measures 44 microvolts, approximately which, if any, of the following values of agc is developed?

1. 44 microvolts
2. 50 microvolts
3. 94 microvolts
4. None of the above

1-62. To automatically compensate for input signal strength variations within a receiver, which of the following types of circuits are added?

1. Afc
2. Nfc
3. Agc
4. Nsu

1-63. AgC circuitry within a receiver uses a portion of which of the following detector voltage components as a feedback signal to preceding stages?

1. Dc
2. Ac
3. IF
4. Audio

1-64. Which of the following types of agc voltage drives an amplifier toward cutoff?

1. Saturation
2. Delayed
3. Reverse
4. Forward

1-65. What is the purpose of the squelch circuit in a receiver?

1. To attenuate very strong signals in order to prevent their overdriving the remaining stages in the receiver
2. To suppress receiver noise output when no input signal is being received
3. To suppress the electronic "whine" of the rf amplification stage
4. To reject signals of other than the desired frequency should the receiver drift off frequency

1-66. How does a receiver accomplish the squelch function?

1. By proportional blocking of the rf amplifier stage output
2. By blocking the detector or audio amplifier when there is no signal
3. By switching an inductive/capacitive filter into the output of the last rf amplifier
4. By switching in a matched-frequency stage which passes matching frequencies and rejects all others

1-67. A quartz crystal filter is used in a communications receiver to improve which of the following characteristics?

1. Fidelity
2. Sensitivity
3. Selectivity
4. Reproduction

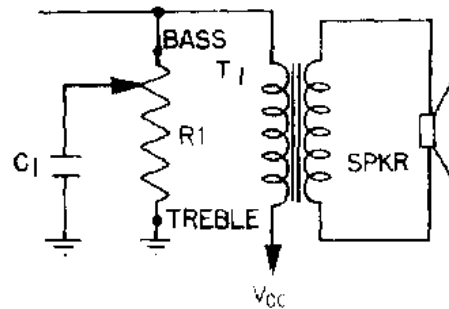

Figure 1B.

IN ANSWERING QUESTION 1-68, REFER TO FIGURE 1B.

1-68. When the wiper of R1 is placed in the full treble position, which of the following actions occur?

1. Bass response is improved
2. High frequency shunting is reduced
3. Higher frequencies are shunted to ground
4. The capacitor and resistor are placed in parallel

1-69. Automatic frequency control circuits are used in a receiver for which of the following purposes?

1. To adjust IF amplifier gain
2. To correct for oscillator frequency drift
3. To extend the frequency range of the receiver
4. To automatically tune the receiver to the desired frequency

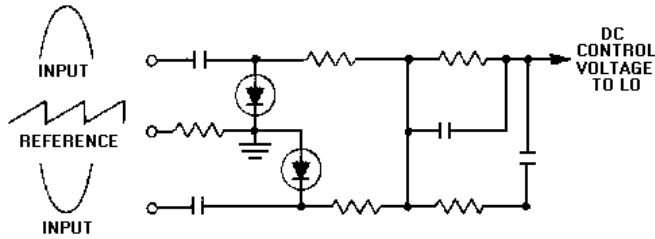

Figure 1C.

IN ANSWERING QUESTIONS 1-70 AND 1-71, REFER TO FIGURE 1C.

1-70. What is the phase relationship between the input signals fed to the diodes?

1. In phase
2. 90 degrees out of phase
3. 180 degrees out of phase
4. 270 degrees out of phase

1-71. A change in oscillator frequency will change which of the following input relationships between the sawtooth reference voltage and the incoming signal?

1. Phase
2. Voltage
3. Current
4. Amplitude

1-72. How is the long term stability and accuracy required of modern communications receivers attained?

1. Through the use of a single, crystal-controlled oscillator, as the local oscillator
2. Through the use of an electron-coupled oscillator, as the local oscillator
3. Through a process of automatic frequency control
4. Through a process known as frequency synthesis

1-73. When using the frequency synthesis process, a signal of the desired accuracy and stability is produced by which, if any, of the following methods?

1. Automatic frequency control, that is, by sensing the difference between the oscillator frequency and the desired frequency and automatically compensating for this difference
2. Using a crystal-controlled oscillator to produce a stable high frequency, and through the process of frequency division selecting a subharmonic of this frequency as the desired frequency
3. The heterodyning and selection of frequencies which are not harmonically related to each other
4. None of the above

1-74. Permanent magnet speakers respond quite well to which of the following audio frequency ranges?

1. Low
2. High
3. Mid band
4. Each of the above

1-75. For which of the following reasons do most standard Navy headphones respond poorly to low frequencies?

1. Small diaphragm size
2. Diaphragm inflexibility
3. Both 1 and 2 above
4. Input signal filtering

ASSIGNMENT 2

Textbook assignment: Chapter 3, "Fundamental Systems Equipment," pages 3-1 through 3-47.

2-1. In a basic communications voice system, which of the following functions occur in the handset during the receive process?

1. Correction voltages are fed to the local oscillator
2. Phasing voltages are received from the master oscillator
3. Voice energy is transformed into electronic impulses
4. Electrical energy is converted to acoustical energy

2-2. Radio set control units are often used aboard ship to remotely control transmitters and receivers. Under standard operating conditions what is the maximum number of units that can be paralleled with a single transmitter and receiver group?

1. One
2. Two
3. Eight
4. Four

2-3. When you are using a transmitter transfer switchboard, what is the maximum number of transmitters that may be connected to a single remote control station?

1. One
2. Two
3. Eight
4. Four

THIS SPACE LEFT BLANK
INTENTIONALLY.

2-4. You are using a radio set control unit to remotely control 1 of 8 transmitters. Operating knob number 1 on transmitter transfer switchboard number 1 is used to select transmitters 1 through 6. If you want to control transmitter number 7, what switch position must be selected?

1. 1
2. Any of 1-6
3. X
4. OFF

2-5. On a receiver transfer switchboard, each switch position is connected to what maximum number of receivers?

1. One
2. Two
3. Three
4. Four

IN ANSWERING QUESTIONS 2-6
THROUGH 2-13, REFER TO THE RADIO
TRANSMITTING SET DISCUSSED IN
CHAPTER 3.

2-6. The impedance matching of equipment to transmission line is accomplished by which of the following equipment groups?

1. A radio transmitter
2. An antenna coupler
3. An rf amplifier
4. A power supply

2-7. The output power of the transmitter unit drives which of the following units?

1. The rf amplifier
2. The power supply
3. The antenna coupler
4. The antenna coupler control

- 2-8. The rf amplifier receives digital tuning information that is generated in which of the following units?
1. The receiver
 2. The transmitter
 3. The coupler control
 4. The radio set control
- 2-9. In some installations tuning must be done without the use of rf power, as rf is suppressed except during brief transmission periods. Under these conditions, which of the following methods of tuning should be used?
1. Silent
 2. Anti-jam
 3. Automatic
 4. Semiautomatic
- 2-10. Operator controlled tuning of the antenna coupler group by the use of front panel controls is possible during which of the following modes of operation?
1. Silent and manual
 2. Manual and automatic
 3. Semiautomatic and silent
 4. Automatic and semiautomatic
- 2-11. Once tuned, the antenna coupler is able to handle which of the following maximum amounts of power?
1. 500 watts average
 2. 2,000 watts average
 3. 250 watts peak envelope
 4. 1,000 watts peak envelope
- 2-12. The antenna coupler is pressurized with dry nitrogen for which of the following reasons?
1. To prevent corona
 2. To prevent arcing
 3. To aid in internal heat transfer
 4. Each of the above
- 2-13. You are using the cw mode of the radio transmitter unit. The 500-kilohertz local carrier is directly inserted into which of the following circuits?
1. The rf amplifiers
 2. The IF amplifiers
 3. The modulator
 4. The detector
- IN ANSWERING QUESTIONS 2-14 THROUGH 2-16, REFER TO THE RADIO RECEIVER DISCUSSED IN CHAPTER 3.
- 2-14. Adjacent-channel selectivity and image-frequency suppression have been improved in this receiver by the addition of which of the following features?
1. Digital tuning
 2. Triple conversion
 3. Front panel readout
 4. Very accurate frequency standard
- 2-15. The full accuracy of the frequency standard is sacrificed when which of the following types of tuning is used?
1. Vernier
 2. Automatic
 3. 1-kilohertz incremental
 4. 100- or 500-hertz incremental
- 2-16. The receiver demodulates and provides audio outputs for which of the following types of received signals?
1. Fm, AM, and fsk
 2. AM, cw, and isb
 3. Cw, fm, and isb
 4. Lsb, usb, and fm
- 2-17. A receiving antenna patch panel serves which of the following functions?
1. Terminates lines leading to receivers
 2. Terminates incoming antenna transmission lines
 3. Both 1 and 2 above
 4. Physically connects transmitters to receivers

- 2-18. Transmitting antenna patch panels are interlocked with the transmitter for which of the following reasons?
1. Safety
 2. Ease of operation
 3. Ease of maintenance
 4. Both 2 and 3 above
- 2-19. A transmit multicoupler provides which of the following functions?
1. Receiver isolation
 2. Transmitter tuning
 3. Additional amplification
 4. Isolation between transmitters
- 2-20. In a manual telegraph circuit, the only two conditions are marking and spacing. Marking is characterized by which of the following descriptions?
1. The key is open
 2. Current is flowing
 3. Current is not flowing
 4. The armature is retracted by a spring
- 2-21. A teletypewriter code signal consists of 7 units. Of the following functions, which describes the middle 5 units?
1. Provides channel data
 2. Carries the intelligence
 3. Signals stop information
 4. Signals start information
- 2-22. Which of the following terms describe the time between a space and mark or mark and space condition in a teletypewriter?
1. Movement
 2. Variation
 3. Transition
 4. Character interval
- 2-23. The time interval between words when using the Morse code is equal to which of the following durations?
1. 1 dot
 2. 7 dots
 3. 3 dashes
 4. 5 dashes
- 2-24. When you are using the five-unit code in teletypewriter operation, what is the maximum number of combinations available that will print letters, figures, function signs, and numerals?
1. 30
 2. 32
 3. 60
 4. 74
- 2-25. When you are using the teletypewriter five-unit code, which of the following signals are used to increase the printing capacity of the equipment?
1. Inverter
 2. Combiner
 3. Case-shift
 4. Type-adjust
- 2-26. Which, if any, of the following modes of teletypewriter operation is more often used in high-speed data systems?
1. Start-stop
 2. Synchronous
 3. Asynchronous
 4. None of the above
- 2-27. In teletypewriter operation, what term defines the length of time required to transmit one letter, figure, function sign or numeral?
1. Baud rate
 2. Bit speed
 3. Code length
 4. Character interval

- 2-28. Synchronous teletypewriter systems are characterized by which of the following features when compared to asynchronous systems?
1. Internal timing signals are always used
 2. Only the start-stop element must be transmitted
 3. Only the intelligence elements must be transmitted
 4. Signal quality determines receiver line signal condition
- 2-29. When you are referring to the unit of teletypewriter signaling speed, the reciprocal of the time (in seconds) of the shortest signal element is described by which of the following terms?
1. Unit code
 2. Baud rate
 3. Bits per second
 4. Words per minute
- 2-30. The teletypewriter condition where current flow represents a mark and no current flow represents a space occurs in which of the following types of operation?
1. Polar
 2. Arctic
 3. Biased
 4. Neutral
- 2-31. You are using neutral keying and the teletypewriter type hammer continually strikes the type box but there is no printing or type box movement across the page. What is the name of this condition?
1. Debugging
 2. Running open
 3. Baudot blanking
 4. Decoding at random
- 2-32. Of the following equipment which one changes teletypewriter dc pulses to mark and space modulation for the transmitter carrier wave?
1. A comparator
 2. A modulator
 3. A converter
 4. A keyer
- 2-33. To change an rf signal to do pulses for teletypewriter operation, you must use a receiver and what other piece of equipment?
1. A keyer
 2. A converter
 3. A comparator
 4. A demodulator
- 2-34. A tone-modulated radio teletypewriter system uses what modulation method to change dc mark and space impulses into audio electrical impulses?
1. Amplitude
 2. Frequency
 3. Phase
 4. Pulse
- 2-35. In a basic tone-modulated radio teletypewriter system, separation of the audio signal from the carrier is accomplished by what process?
1. Conversion
 2. Modulation
 3. Selection
 4. Detection
- 2-36. In a radio-frequency-carrier shift system, what equipment is the source of radio-frequency excitation voltages?
1. The inverter
 2. The converter
 3. The comparator
 4. The transmitter keyer

- 2-37. The keyer in a radio-frequency-carrier shift system is normally adjusted for which of the following maximum frequency spreads?
1. 425 hertz
 2. 500 hertz
 3. 750 hertz
 4. 850 hertz
- 2-38. Of the following teletypewriter equipment, which one is used to store incoming teletypewriter messages on tapes for future transmission on a transmitter distributor?
1. A keyboard
 2. A page printer
 3. A typing reperforator
 4. A communication patching panel
- 2-39. Teletypewriter patch panels perform which of the following functions?
1. They provide a means for connecting the teletypewriter equipment in various combinations
 2. They provide a means for permanently connecting commonly used combinations of equipment
 3. They provide a central point for connecting the dc supply voltage to the teletypewriter circuits
 4. Each of the above
- 2-40. You are working with a teletypewriter patch panel. What color signifies that secure information is being passed?
1. Red
 2. Gray
 3. Black
 4. Green
- 2-41. In any switching operation between plugs and jacks of a teletypewriter panel, if the cord plug is pulled from the set (machine) jack before the plug is removed from the looping jack, which of the following conditions will occur?
1. A dangerous dc voltage will be produced on the exposed plug
 2. All teletypewriter messages in the channel will be interrupted
 3. Both 1 and 2 above
 4. Classified information will be Compromised
- 2-42. Cryptographic equipment performs which, if any, of the following functions?
1. Encodes and decodes messages
 2. Reduces mean-time between messages
 3. Acts as an additional power amplifier
 4. None of the above
- 2-43. In the radio-frequency-carrier shift system, translation of an rf signal to an audio signal is done by which of the following equipment?
1. A converter
 2. A comparator
 3. A radio receiver
 4. An antenna filter
- 2-44. A comparator compares signal strength during which of the following types of receiver operation?
1. Single
 2. Space diversity
 3. Frequency diversity
 4. Both 2 and 3 above

- 2-45. In an afts transmit system, the conversion of dc signals into audio tone-shift signals is done by which of the following pieces of equipment?
1. Cryptographic
 2. Tone terminal set
 3. Converter/comparator
 4. Modulator/demodulator
- 2-46. The process of simultaneous transmission of several intelligible signals on the same frequency during the same period of time is called
1. duplexing
 2. simplexing
 3. complexing
 4. multiplexing
- 2-47. What are the two methods of multiplexing?
1. Time-division and frequency-multiplication
 2. Time-division and frequency-division
 3. Time-multiplication and frequency-multiplication
 4. Time-multiplication and frequency-division
- 2-48. In time-division multiplexing, assume that a 4,000-hertz tone is applied to each of six channels in a telegraph transmitter and that each channel is to be sampled at a rate of 2.5 times during each cycle of the 4,000-hertz tone. At what speed, in revolutions per second, must the rotating switch turn to accomplish this sampling rate?
1. 3,000
 2. 4,000
 3. 7,200
 4. 10,000
- 2-49. In time-division multiplexing, what drawback is encountered if an excessive number of frequency channels is used?
1. Static is increased
 2. Bandwidth is increased
 3. Switching becomes unreliable
 4. Reception becomes unintelligible
- 2-50. How many times per cycle is a practical time-division multiplex system optimally sampled?
1. 1.5
 2. 2.0
 3. 2.4
 4. 3.1
- 2-51. Frequency-division multiplexing systems transmit and receive during a maximum of how many degrees of a sinewave?
1. 90
 2. 180
 3. 270
 4. 360
- 2-52. By using frequency-division multiplexing, tty circuits may carry a maximum of how many single, 3,000-hertz channels?
1. 12
 2. 16
 3. 18
 4. 24
- 2-53. In a 16-channel tty-multiplexing system, the maximum difference between a mark and a space, for any give channel, is how many hertz?
1. 85
 2. 382.5
 3. 425
 4. 467.5

- 2-54. Weather charts and photographs are examples of materials transmitted by
1. aw telegraphy
 2. FAX (facsimile)
 3. landline teletypewriter
 4. rttv (radio teletypewriter)
- 2-55. Which of the following facsimile transceiver operations consists of subdividing the picture in an orderly manner and into a large number of segments?
1. Scanning
 2. Recording
 3. Receiving
 4. Transmitting
- 2-56. The scanning operation is accomplished in the facsimile transmitter by a
1. scanning drum and a phototube arrangement
 2. scanning drum and aperture tube
 3. spiral drum and amplifier
 4. phototube amplifier
- 2-57. The purpose of the phototube in facsimile equipment is to
1. illuminate a segment of the picture
 2. produce the carrier signal for the exciter lamp
 3. maintain the output voltage at a predetermined fixed value
 4. transform varying amounts of light into electrical signals
- 2-58. Which of the following means is used to synchronize the receiving drum with the transmitting drum in a radio facsimile system?
1. The drums are mechanically linked
 2. Each drum is started by an accurate clock
 3. Both drums are operated by synchronous motors
 4. Both drums are stepped around a precise number of steps by a relay
- 2-59. In a facsimile system, which of the following methods is used to accomplish framing at the receiver unit?
1. A synchronous clutch mechanism is actuated
 2. A primary time/frequency standard is switched in
 3. A series of phasing pulses are transmitted prior to image transmission
 4. A synchronous motor at both the transmitter and receiver is engaged
- 2-60. Of the following terms, which one is primarily concerned with compromising emanations?
1. Tempest
 2. Radiation hazard
 3. Quality monitoring
 4. Electromagnetic interference
- 2-61. Of the following fundamental requirements of a military communications system, which one, if any, is most important?
1. Speed
 2. Security
 3. Reliability
 4. None of the above
- 2-62. What one assumption may be made regarding all military radio transmissions?
1. They are secure
 2. They have been encrypted
 3. They have been decrypted
 4. They have been intercepted
- 2-63. Scheduled maintenance in support of QMCS is designed to alert you to which of the following problems?
1. Safety hazards
 2. Equipment failure
 3. System degradation
 4. Improper operating procedures

- 2-64. Of the following terms, which one is defined as the ability of an electronic system to perform its individual functions without interference?
1. Electronic countermeasures
 2. Electromagnetic interference
 3. Electromagnetic compatibility
 4. Electronic counter-countermeasures
- 2-65. The sources of electromagnetic radiations that reduce receiver performance are known by which of the following terms?
1. Electronic countermeasures
 2. Electromagnetic interference
 3. Electromagnetic compatibility
 4. Electronic counter-countermeasures
- 2-66. Which of the following categories of electromagnetic interference includes interference generated by electrically charged raindrops?
1. Natural
 2. Functional
 3. Incidental
 4. Hull-generated
- 2-67. Cross modulation is a form of emi where the desired carrier intermodulates with an undesired signal. Which of the following devices should minimize this interference?
1. Filters
 2. Preselectors
 3. Both 1 and 2 above
 4. Preamplifiers
- 2-68. Shipboard receive systems are designed to include protective circuitry between the antenna and the receiver that prevent which of the following problems?
1. Degradation of overall receiver performance by processing of off-frequency signals
 2. Decrease of desired signal amplification
 3. Burn out of front-end stages
 4. Each of the above
- 2-69. Of the following body organs, which are considered the most vulnerable to radiation hazards (RADHAZ)?
1. Eyes and testes
 2. Heart and lungs
 3. Liver and spleen
 4. Kidneys and brain
- 2-70. Which of the following methods of reducing rf burn hazards is the most useful and widespread technique used?
1. Operate receivers only
 2. Vary the operating frequency
 3. Bond and ground all metallic objects
 4. Operate transmitters only at low power
- 2-71. The greatest hazard from thermal effects appears to come from equipment operated in which of the following frequency ranges?
1. 1 to 3 gigahertz
 2. 2 to 30 megahertz
 3. 30 to 300 kilohertz
 4. 225 to 500 megahertz

2-72. You have been working on a piece of equipment and your eyes have been exposed to high-intensity microwaves. Which of the following types of eye problems may occur?

1. Detached retina
2. Conjunctivitis
3. Cataracts
4. Glaucoma

ASSIGNMENT 3

Textbook assignment: Chapter 4, "Introduction to Satellite Communications," pages 4-1 through 4-21.
Chapter 5, "Introduction to Miscellaneous Systems and Equipment," pages 5-1 through 5-20.

- 3-1. What artificial satellite is credited with starting the era of space technology?
1. Vela
 2. Midas
 3. Score
 4. Sputnik
- 3-2. There are two types of communications satellites. What type acts as a repeater for the signal?
1. Active
 2. Passive
 3. Reflecting
 4. Retransmitting
- 3-3. Transmission of information to a satellite is done on what frequency?
1. Up-link
 2. Down-link
 3. Transponder
 4. Termination
- 3-4. An earth terminal receives signals on what frequency?
1. Up-link
 2. Transmit
 3. Down-link
 4. Termination
- 3-5. Of the following orbit parameters, which one describes the basic orbit shape of a communications satellite?
1. Inclined or polar
 2. Polar or equatorial
 3. Elliptical or circular
 4. Synchronous or nonsynchronous
- 3-6. When the period of an orbit is identical to that of the earth, the orbit is
1. synchronous
 2. asynchronous
 3. subsynchronous
 4. near-synchronous
- 3-7. What is the parameter in the orbit of a satellite that refers to the point nearest the center of the earth?
1. Apogee
 2. Perigee
 3. Altitude
 4. Inclination
- 3-8. As a reference, perigee and apogee are measured in which of the following units?
1. Nautical miles
 2. Statute miles
 3. Light years
 4. Kilometers
- 3-9. A satellite which has a flight path that does not coincide with the equatorial plane of the earth is said to be in what type of orbit?
1. A circular
 2. An inclined
 3. An elliptical
 4. An equatorial

- 3-10. A satellite orbiting with an angle of inclination of approximately 90 degrees describes which of the following types of orbit?
1. Polar
 2. Equatorial
 3. Synchronous
 4. Asynchronous
- 3-11. In order to cover most of the earth except the polar regions, what is the minimum number of satellites that must be orbited?
1. 5
 2. 6
 3. 3
 4. 4
- 3-12. There were many limitations that caused problems on the first communications satellites. Of the following problems, which one was considered the most severe?
1. The excessive size
 2. The excessive weight
 3. The too low orbit altitude
 4. The lack of a suitable power source
- 3-13. Which of the following power sources is/are considered a practical choice for satellites?
1. Solar cells only
 2. Storage batteries only
 3. A combination of solar cells and storage batteries
 4. Sunlight and leclanche cells
- 3-14. What development in satellite communications improved back-up power during eclipses?
1. The installation of a battery back-up
 2. The installation of a nuclear power source
 3. The continuous exposure of solar cells to the sun
 4. The increase in solar cells mounted on the surface of the satellite
- 3-15. Why is satellite orientation in space so important?
1. Because it is a necessity for back-up power
 2. To meet the requirements of spin stabilization
 3. To ensure that sunlight converging on the solar cells is converted to electrical power
 4. Because it is essential for maximum solar cell exposure to the sun and satellite antenna visibility to earth terminals
- 3-16. Why are communications satellite earth terminals generally located in areas remote from the actual users?
1. To minimize cost
 2. To minimize jamming
 3. To minimize rf interference
 4. To allow for future expansion
- 3-17. Which of the following characteristics is a requirement for a satellite earth terminal antenna?
1. It must be omnidirectional
 2. It must be of the Franklin collinear type
 3. It must have low gain and be highly directional
 4. It must be capable of transmitting and receiving signals simultaneously
- 3-18. One earth terminal antenna uses a cluster of four 10-foot parabolic antennas. This array is effectively a total of how many feet in diameter?
1. 18
 2. 20
 3. 32
 4. 40

- 3-19. Why do satellite earth terminals require highly sensitive receivers?
1. To overcome the down-link power losses
 2. To permit extraction of the desired communications information from the received signal
 3. Both 1 and 2 above
 4. Because of the signal scatter effect of the antennas
- 3-20. Which of the following functions is performed by the exciter stage of an earth terminal transmitter?
1. Modulation of the IF carrier
 2. Translation of the IF signal to the up-link frequency
 3. Amplification of the IF signal to the level required by the receiver
 4. Conversion of the down-link frequency to an IF
- 3-21. Telemetry equipment used in satellite communications systems performs which of the following functions?
1. They monitor the operating conditions within the satellite
 2. They provide local control for satellite operations
 3. They furnish high-capacity wide-band tty trunks
 4. They measure ambient weather conditions
- 3-22. A typical shipboard receive-only satellite system uses which of the following types of modulation?
1. Pulsed or amplitude
 2. Pulsed or frequency
 3. Amplitude or phase-shift-key
 4. Frequency or phase-shift-key
- 3-23. Locating a near-synchronous satellite is rather simple for which of the following reasons?
1. It is stationary
 2. It is moving north to south
 3. It has a slow relative motion
 4. It has a fast relative motion
- 3-24. What is the name of the table that provides coordinates of a satellite at specific times?
1. Bearing location
 2. Longitudinal
 3. Propagation
 4. Ephemeris
- 3-25. To establish radio contact with a satellite, an earth terminal must know which of the following satellite data?
1. Attitude
 2. Elevation
 3. Operating speed
 4. Angle of inclination
- 3-26. Satellite down-link frequency variations occur most often from satellites in which of the following orbits?
1. Low altitude elliptical
 2. Medium altitude circular
 3. High altitude synchronous
 4. Superhigh altitude near-synchronous
- 3-27. Of the following terms, which one describes the period of time required for one earth terminal to yield control of a satellite to another?
1. Slewing
 2. Hand over
 3. Control shift
 4. Terminal continuity

- 3-28. When compared to hf communications, which of the following advantages are unique to satellite communications links?
1. They are more reliable and flexible
 2. They are unaffected by propagation variations affecting hf
 3. They do not require repeater stations or troposcatter links
 4. Each of the above
- 3-29. Which of the following factors limits the reliability of active satellite communications system?
1. The reflection or refraction of signals
 2. The reliability of the equipment used
 3. The skill of the operating and maintenance personnel
 4. Both 2 and 3 above
- 3-30. An increase of invulnerability to jamming of satellite communications systems is seen through the use of which of the following features?
1. Narrow bandwidths
 2. Low transmitter output power
 3. Antijamming modulation techniques
 4. Omnidirectional earth terminal Antennas
- 3-31. Which of the following statements best describes the advantage of satellite communications in terms of flexibility?
1. The antenna group of any earth terminal can be mounted on the weather deck of a ship
 2. Certain earth terminals are housed in vans and can be transported to remote areas
 3. Military satellite communications are capable of handling hundreds of voice channels
 4. A high degree of protection from jamming is afforded by the highly Directional antennas at earth terminals
- 3-32. A satellite communications system is limited by which of the following characteristics?
1. The attitude of the satellite repeater
 2. The technical design of the satellite
 3. The immobility of the satellite
 4. The mobility of the satellite
- 3-33. Active communications satellite systems have two major limitations. What are they?
1. Complex preamplifiers and high gain antennas
 2. Up-link transmitter power and earth terminal antenna size
 3. Down-link transmitter power and uplink receiver sensitivity
 4. Down-link receiver sensitivity and external atmospheric noise
- 3-34. The rf power output of a satellite communications system is severely limited due to which of the following factors?
1. A lack of adequate jamming capabilities
 2. An inefficient solar-cell package aboard the satellite
 3. An unstable satellite orientation with respect to the horizon
 4. A requirement for large antenna-farm earth-terminal systems
- 3-35. The availability of a satellite to act as a relay station between two earth terminals depends upon which of the following considerations?
1. The mobility of the satellite
 2. The location of the earth terminals
 3. The operating frequencies of the satellite
 4. The electronic design of the earth terminals

3-36. What determines the length of time that a nonsynchronous satellite in a circular orbit will be in the zone of mutual visibility?

1. Height of the orbit
2. Earth terminal antenna size
3. Down-link transmitter power
4. Up-link receiver sensitivity

3-37. Satellite communications systems are being rapidly developed by the Navy for which of the following reasons?

1. To replace microwave links
2. To relieve dependence on hf communications
3. To reduce procurement and development costs
4. To replace all physically large size equipment

3-38. In an mf transmitter, the frequency generator is used during which of the following modes of operation?

1. AM
2. Fm
3. Cw
4. Fsk

3-39. The pre-ipa and ipa in an mf transmitter are which of the following types?

1. Linear, tuned
2. Linear, untuned
3. Non-linear, tuned
4. Non-linear, untuned

3-40. Of the following communications system components, which one is a device that is nonradiating, absorbs rf, and has the characteristic impedance of the antenna?

1. Helix
2. Dummy load
3. Rf tuning unit
4. Frequency synthesizer

3-41. Which of the following antenna arrays consists of quarter-wave, vertically polarized stubs?

1. Broadside
2. Parasitic
3. Top-hat
4. Triatic

IN ANSWERING QUESTIONS 3-42 THROUGH 3-44, REFER TO THE MEDIUM FREQUENCY AND BELOW RECEIVER COVERED IN CHAPTER 5.

3-42. With one exception, the receiver has the same circuitry as any high frequency receiver. What is the one exception?

1. The components are doubled up
2. The local oscillator is eliminated
3. The radio-frequency amplifier is replaced by a video amplifier
4. The audio-frequency amplifier is replaced by a traveling-wave tube

3-43. The rejection of input frequencies above 900-kilohertz is performed by which of the following circuits?

1. An attenuator
2. A video amplifier
3. A low-pass filter
4. A calibration oscillator

3-44. The demodulation of ssb, cw, and fsk signals is performed by which of the following circuits?

1. An fm detector
2. A phase splitter
3. An audio amplifier
4. A product detector

- 3-45. Of the following amplifiers, which one has a high gain, low noise, wide bandwidth and is operated in the microwave region?
1. A magnetic
 2. An operational
 3. A differential
 4. A traveling-wave-tube
- 3-46. In a line-of-sight communications system, propagation is affected by which of the following layers of the atmosphere?
1. Ionosphere
 2. Troposphere
 3. Stratosphere
 4. Thermosphere
- 3-47. Horn-driven paraboloid antennas have which of the following characteristics?
1. High gain, narrow beam width
 2. Low gain, narrow beam width
 3. High gain, wide beam width
 4. Low gain, wide beam width
- 3-48. Line-of-sight systems are configured in many ways with regards to channel width and number of channels. A voice system with a channel width of 4-kilohertz has a total of how many channels available for transmission?
1. 200
 2. 400
 3. 600
 4. 800
- 3-49. A one-hop transmission of a tropo-scatter system can travel what maximum distance?
1. 1200 miles
 2. 1000 miles
 3. 800 miles
 4. 500 miles
- 3-50. Of the following advantages, which one is primary to the NTDS when compared with conventional data systems?
1. Speed
 2. Distance
 3. Security
 4. Reliability
- 3-51. The NTDS uses which of the following data transmission links?
1. 14, 11, 4A
 2. 14A, 11, 4
 3. 14, 11A, 4
 4. 14A, 11A, 4A
- 3-52. Of the following NTDS links, which one(s) is/are only used as a one-way broadcast?
1. 14
 2. 4A
 3. 11, 14
 4. 4A, 11
- 3-53. Portable radio sets are used primarily for which of the following types of communications?
1. Amphibious
 2. Air-to-air
 3. Electronic warfare
 4. Anti-submarine warfare
- 3-54. When designing portable and pack radios, which of the following characteristics is the prime consideration?
1. Must be solar powered
 2. Must be heavy and rugged
 3. Must have high output power
 4. Must be light-weight and compact

IN ANSWERING QUESTIONS 3-55 THROUGH 3-58, REFER TO THE EMERGENCY LIFEBOAT TRANSMITTER COVERED IN CHAPTER 5.

- 3-55. Search and rescue stations are divided into groups that have distinct rescue functions. Emergency lifeboat transmissions are designed for reception by a total of how many of these groups?
1. 5
 2. 2
 3. 3
 4. 4
- 3-56. What are the operating frequencies of the transmitter?
1. 8,364 kHz and 500 MHz
 2. 500 MHz and 8,864 kHz
 3. 500 kHz and 8,364 kHz
 4. 500 kHz and 8,864 kHz
- 3-57. What is the primary source of power for the transmitter?
1. External ac
 2. Wind generator
 3. Internal battery
 4. Handcrank generator
- 3-58. When in the automatic mode of operation, the transmitter transmits (a) while changing frequency every (b) seconds?
1. (a) The SOS distress signal
(b) 50
 2. (a) Voice messages
(b) 20
 3. (a) Voice messages
(b) 50
 4. (a) The SOS distress signal
(b) 20
- 3-59. What is the maximum number of channels available when you are using the emergency portable transceiver covered in chapter 5?
1. 5
 2. 2
 3. 3
 4. 4
- 3-60. A laser operates in which of the following areas of the light spectrum?
1. Red
 2. Infrared
 3. Ultraviolet
 4. At or near visible light
- 3-61. The principle of the laser is much like that of, which of the following electronic components?
1. Hall generator
 2. Reflex klystron
 3. Traveling-wave-tube
 4. Very high-Q cavity resonator
- 3-62. Which of the following components is a close relative of the laser?
1. Thyristor
 2. Photo transistor
 3. Light emitting diode
 4. Photovoltaic transducer
- 3-63. Laser transmissions during adverse weather conditions experience which of the following problems?
1. Absorption
 2. Refraction
 3. Reflection
 4. Diffraction