

The REAR SIGHT is mounted on the receiver over the well. The LEAF, as viewed when laid, is shown in plan in Fig. 75, in rear elevation in Fig. 76, and in side elevation in Fig. 77. It comprises the *joint bolt hole A*, the *detent faces B*, the *battle peep sight C*, and the *stop-screw hole D*. The leaf is pivoted on the JOINT BOLT, which, with its NUT, is shown in Fig. 78. The leaf is held raised or laid by means of the REAR SIGHT BASE SPRING, shown in plan in Fig. 79 and in side elevation in Fig. 80. This spring has a *hole E* to receive the REAR SIGHT BASE SPRING SCREW, shown in Fig. 81, and has *lips F* to enter undercuts in the spring seat. Its *free end G* coacts with the detent faces B on the leaf and has a *slot H* to give clearance for the battle peep sight C, should the leaf be struck back. The groove in the free end G holds the leaf at 45°, a convenient position for adjusting the slide.

The SLIDE is vertically adjustable on the leaf and is shown in plan in Fig. 82 and elevation in Fig. 83. It includes the *peep sight A*, *leaf slot B*, *indices C*, *catch-pin hole D*, and *spring retaining lug E*. Its removal from the leaf is prevented by the REAR SIGHT SLIDE STOP SCREW shown in Fig. 84. The slide is retained in adjustment by the REAR SIGHT SLIDE CATCH, Fig. 85, which is pivoted on the REAR SIGHT SLIDE CATCH PIN, Fig. 86, and is urged by the REAR SIGHT SLIDE CATCH SPRING, Fig. 87, into engagement with properly spaced notches on the edge of the leaf. The rear sight slide catch spring is seated in the *spring recess* (not shown) in the catch and is held by the spring retaining lug E on the slide. The face of the slide is checked to prevent reflection of light, which would interfere with aiming. The numbers on the leaf indicate hundreds of yards. The notches are at 100-yard intervals from 200 to 900 yards, and at 50-yard intervals from 900 to 1,600 yards.

The STOCK is shown in top view in Fig. 88 and in side view in Fig. 89. The parts are the *butt A*; *small B*; *pistol grip C*; *magazine well D*; *barrel bed E*; *air chambers F*, which reduce the charring effect of a heated barrel; *seat for butt-plate tang G*; *seat for butt-swivel plate H*; *mortise for receiver tang I*; *mortise for safety lock J*; *mortise for sear and trigger slot K*; *mortise for recoil lug L*; *grasping grooves M*; *shoulder for lower band N*; *shoulder for upper band O*; *hole for stock bolt P*; *hole for stock pin Q*; *hole for lower band pin R*. The *hole S* in the butt is for the combination oiler and thong case.

The REAR HAND GUARD is shown in elevation in Fig. 90 and in bottom or inside view in Fig. 91. It has the *rear tenon A*, to receive the hand guard ring; the *front shoulder B*, against which the lower band seats; the *rear liner seat C* and the *middle liner seat D*.

The FRONT HAND GUARD is shown in plan in Fig. 92 and in bottom or inside view in Fig. 93. It has, at its rear end, the *front liner seat E* and at its front end the *front tenon F*, which enters an undercut in the upper band.

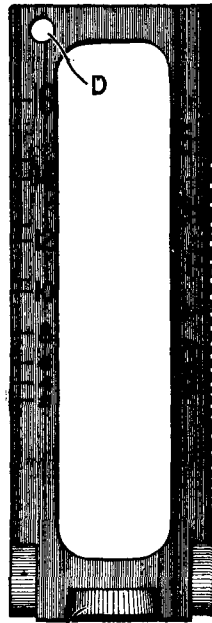

FIG. 75
C

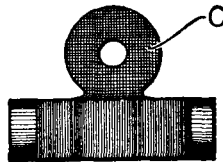

FIG. 76

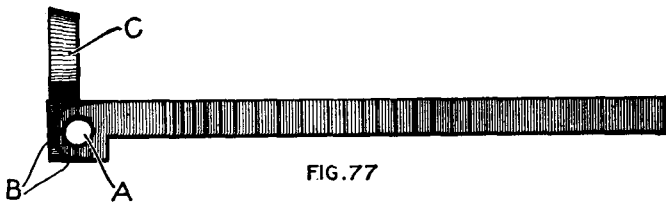

FIG. 77



FIG. 78

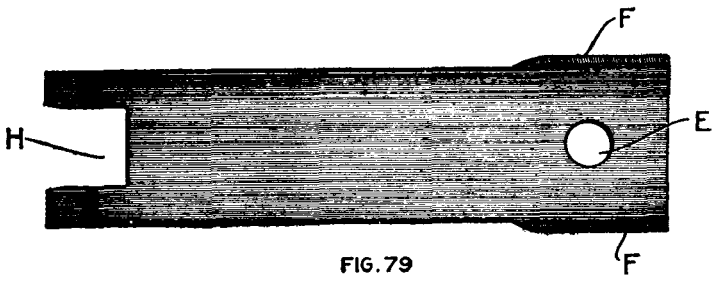

FIG. 79



FIG. 80



FIG. 81



FIG. 84

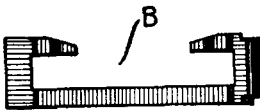

FIG. 82



FIG. 86

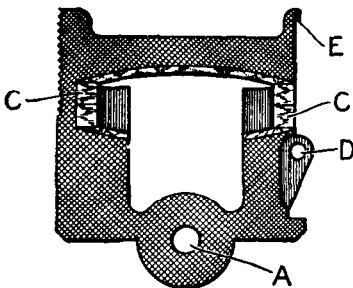

FIG. 83



FIG. 85

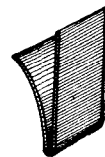

FIG. 87

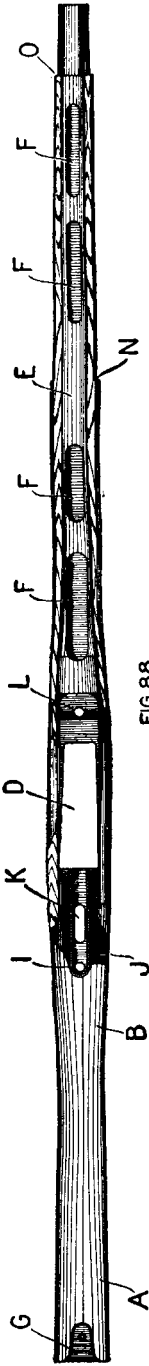

FIG. 88

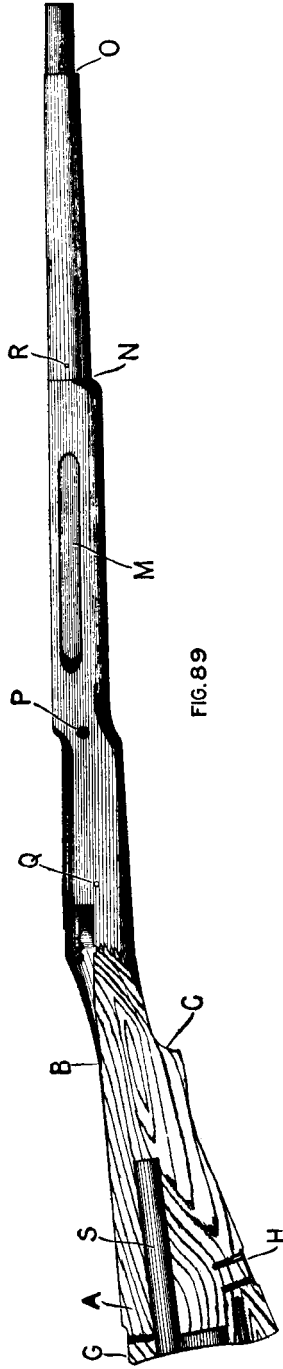

FIG. 89

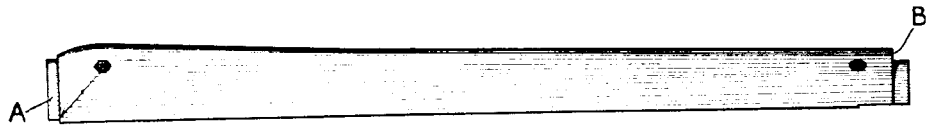

FIG. 90

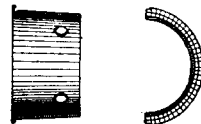

FIG. 94

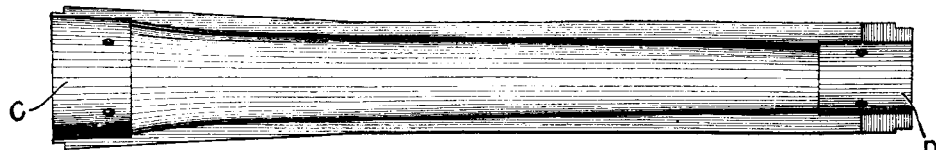

FIG. 91

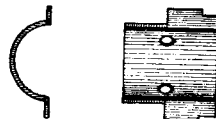

FIG. 95

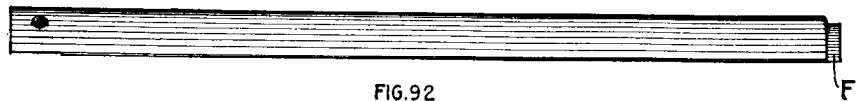

FIG. 92



FIG. 96



FIG. 97



FIG. 93

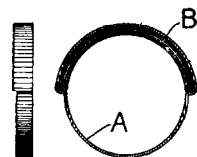

FIG. 98

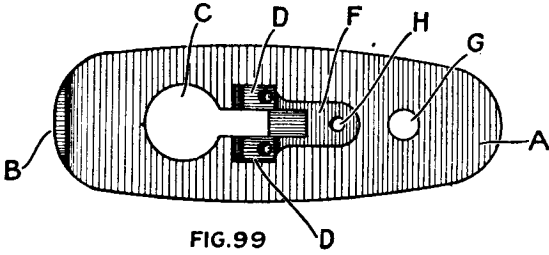

FIG. 99

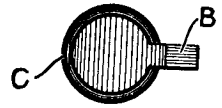

FIG. 101

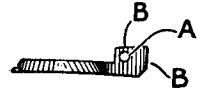

FIG. 102

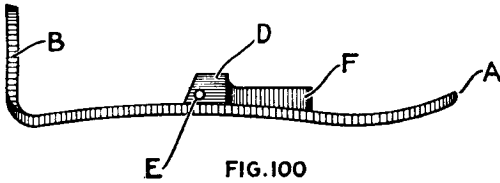

FIG. 100



FIG. 103



FIG. 104



FIG. 105



FIG. 106



FIG. 108



FIG. 107



FIG. 109

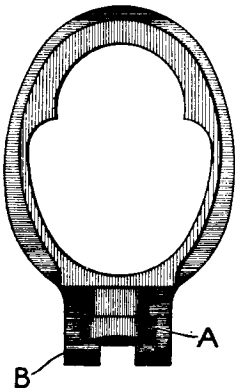

FIG. 110

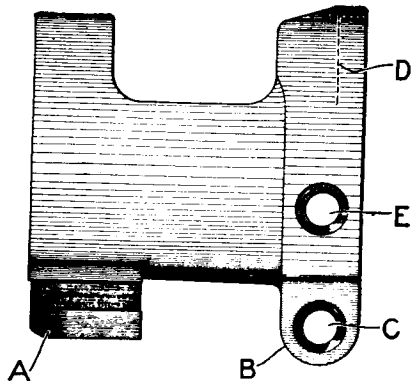

FIG. III



FIG. 112



FIG. 113

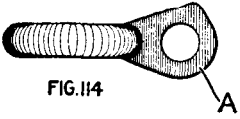

FIG. 114

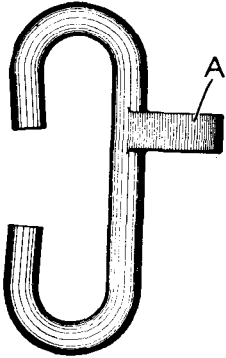

FIG. 115

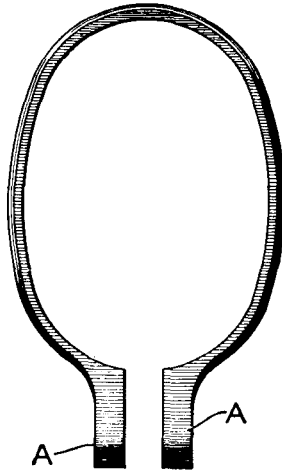

FIG. 116

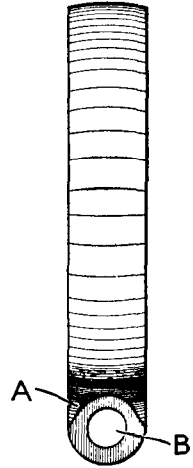

FIG. 117

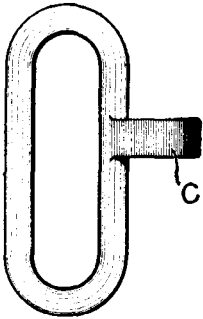

FIG. 118

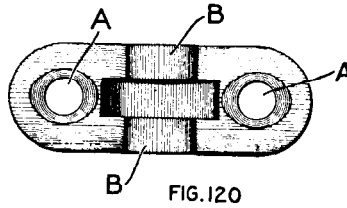

FIG. 120

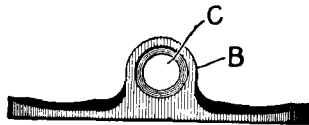

FIG. 121



FIG. 119



FIG. 122

The REAR HAND GUARD LINER is shown in bottom view and section in Fig. 94, and is mounted in the seat C of the rear hand guard. The MIDDLE HAND GUARD LINER, shown in bottom view and section in Fig. 95, is mounted in seat D. The FRONT HAND GUARD LINER, shown in bottom view and section in Fig. 96, is seated in seat E. The three hand guard liners are attached to their respective guards by the HAND GUARD RIVETS, Fig. 97.

The HAND GUARD RING is shown in side and front elevations in Fig. 98. It includes the *barrel loop* A and the *guard seat* B. The rear tenon of the rear hand guard is held in this guard seat. The front tenon of the front hand guard enters an undercut in the upper band. The adjacent ends of the two guards abut, and the joint is lapped by the lower band.

The BUTT PLATE is shown in top view in Fig. 99 and side view in Fig. 100. The parts are the *toe* A; *tang* B; *cap hole* C; *cap ears* D, through which are the *pin holes* E; the *spring lug* F; *hole for large butt-plate screw* G; and *hole for butt-plate spring screw* H. Some manufacturers form the ears integrally with the butt plate; others rivet them in place. There is a hole in the tang for the small butt plate screw.

The BUTT PLATE CAP is shown in inside view in Fig. 101 and in side view in Fig. 102. It has the *pin hole* A, *detent faces* B; and *thumb notch* C; and is pivoted between the ears on the butt plate by the BUTT PLATE PIN, Fig. 103, which is riveted in place. The cap is impositively latched in open and closed positions, by the BUTT-PLATE SPRING, Fig. 104, held by the BUTT-PLATE SPRING SCREW, Fig. 105, and bearing against the detent faces B.

The BUTT-PLATE SCREWS, LARGE and SMALL, are shown in Figs. 106 and 107, respectively. The small screw goes through the hole in the tang.

The STOCK BOLT AND NUT are shown in Fig. 108. The bolt extends transversely through the stock, just to the rear of the recoil lug on the receiver (see P, Fig. 89).

The STOCK PIN, Fig. 109, is a threaded pin, of brass, screwed through a transverse hole in the stock, between the magazine well and the trigger slot (see Q, Fig. 89). Its ends are cut off flush with the sides of the stock.

The UPPER BAND shown in end and side elevation, respectively, in Figs. 110 and 111 has the *bayonet lug* A; *ears* B, in which are the *holes* C for the STACKING-SWIVEL SCREW, Fig. 112; an *undercut* D for the front tenon of the hand guard; and the *upper band screw hole* E to receive the UPPER BAND SCREW shown in Fig. 113.

All swivel screws (Fig. 112) have hollow ends which are expanded by the use of a special expanding tool to prevent their becoming loosened.

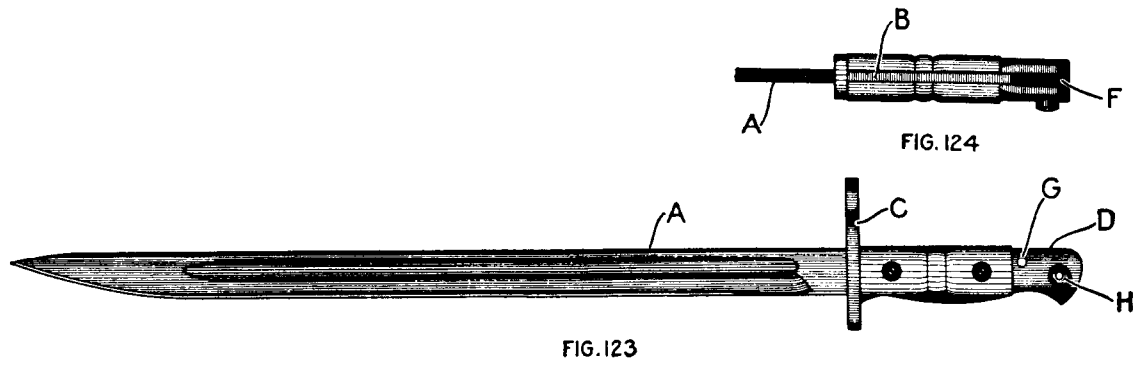

FIG. 123

FIG. 124

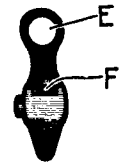

FIG. 125

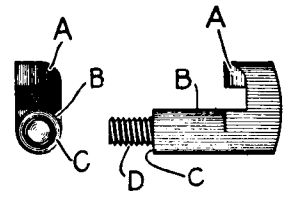

FIG. 126

FIG. 127



FIG. 131

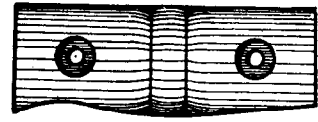

FIG. 132

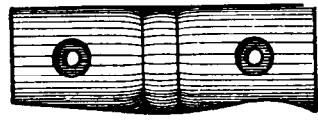

FIG. 133



FIG. 134

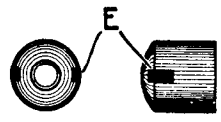

FIG. 128



FIG. 129

FIG. 130

The STACKING SWIVEL is shown in edge and top views, respectively, in Fig. 114 and Fig. 115. It is mounted with its *lug* A between the ears in the upper band, and swivels on the stacking swivel screw above mentioned.

The LOWER BAND, Figs. 116 and 117, has the *ears* A and *holes* B. The LOWER BAND SWIVEL, Fig. 118, has an offset *lug* C which lies between the ears A, and swivels on a screw identical with the stacking-swivel screw, Fig. 112.

The lower band is retained by the LOWER BAND PIN, Fig. 119, which passes through the stock (see R, Fig. 89).

The BUTT-SWIVEL PLATE, Figs. 120 and 121, has the *screw holes* A; *ears* B and *swivel screw holes* C. A swivel and swivel screw, identical with those used in the lower band (Figs. 112 and 118), are used with the butt-swivel plate. The butt-swivel plate is attached to the butt by two BUTT-SWIVEL PLATE SCREWS, Fig. 122.

THE BAYONET, MODEL 1917, AND BAYONET SCABBARD.

The BAYONET is shown in side view in Fig. 123, fragmentary rear edge view in Fig. 124 and top view in Fig. 125.

The *blade* A and *tang* B are forged in one piece; the *guard* C is forced on to the blade, and brazed in place, and the *pommel* D is brazed in place so that these parts practically form a single piece. The guard C is formed with the *barrel ring* E, to surround and thus engage the end of the rifle barrel. The pommel D has a T-shaped *stud slot* F to receive the bayonet stud, on the upper band of the rifle. The *clearing hole* G leads to the end of the stud slot and facilitates the removal of dirt or other obstructions.

The BAYONET CATCH is located at H, Fig. 123, and is illustrated in detail in Figs. 126 and 127, which are end and side elevations, respectively. It includes the *latch* A; *body* B; *shoulder* C; and *threads* D.

The CATCH THUMB PIECE, shown in outer end view in Fig. 128, side view in Fig. 129, and inner end view in Fig. 130, screws on to the threads D of the catch, and seats against the shoulder C. It has the *turning slots* E, and *spring seat* F to receive the end of the BAYONET CATCH SPRING, Fig. 131. This spring surrounds and partially guides the body B of the catch, and serves to hold the catch in engaging position, with the thumb piece protruding from the pommel. The catch is released by pressing the thumb piece.

Two counterpart GRIPS (right and left), Figs. 132 and 133, are mounted on the tang, between the pommel and guard, and are held by the BAYONET SCREWS AND NUTS shown in Fig. 134. The grips are counterbored, as shown, to receive the nuts and the heads of the screws.

The marking of bayonets taken over while in course of manufacture for the British Government, includes a canceled British property mark. On the blade, at the guard, on the same side with this, are

the letters "U. S." and the inspector's marks. On the reverse side is "1913" (the British designation of this model), numbers representing the month and year of manufacture, and the maker's name.

Bayonets of later manufacture bear on one side of the blade at the guard the Ordnance escutcheon, the inspector's marks and the letters "U. S." On the reverse side is "1917" (the official U. S. designation of this model) and the maker's name. The bayonets are not serially numbered.

The BAYONET SCABBARD, model of 1917, is shown in side elevation in Fig. 135 and edge view in Fig. 136.

The *body* A is made of sole leather, flesh side out, stitched up the inner side, and painted olive drab. The *ferrule* B and *mouthpiece* C are of sheet steel, browned. The *hanger* D is of russet leather and carries the *double hook* E by which the scabbard is attached to either the pack or the belt. The bayonet is retained in the scabbard by spring fingers (not shown) mounted in the mouthpiece, and serving frictionally to engage the blade.

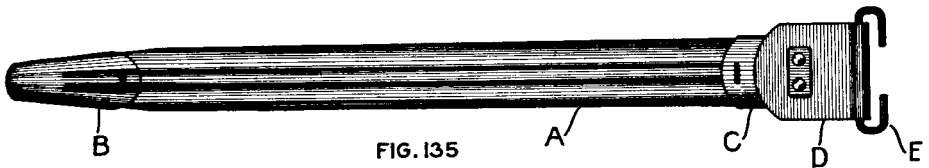

FIG. 135



FIG. 136

APPENDAGES.

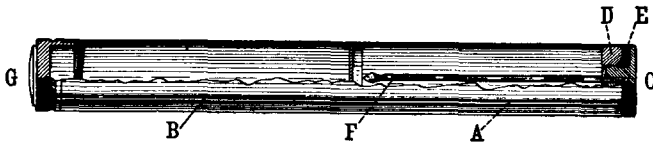

Fig. 137.

The OILER AND THONG CASE, Fig. 137, furnished for every rifle, is carried in the butt of the stock. It consists of a sand blasted and nicked brass tube, about 6 inches long and $\frac{3}{4}$ inch in diameter, divided transversely, near the center, by a partition, with both ends fitted with screw caps. In one section is carried a small supply of sperm oil, and in the other the thong and thong brush used for cleaning the bore of the rifle. The cap on the oil section is fitted with a wire, flattened at its point, which reaches to the bottom of the section and is used for applying oil, a drop or more at a time. *The oil is only for the lubrication of working parts.* The cap is also provided with a leather washer to prevent leakage. The cap

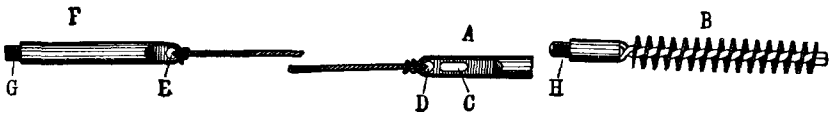

Fig. 138.

on the thong section has a leather pad on its outer surface, which prevents the noise that would result from the oiler striking the butt-plate cap. The oiler should always be inserted in the stock so that the leather-tipped cap will be next to the butt plate cap. The parts as shown in cut are: *Thong case body A and B; oiler collar D*, into which the cap is screwed; *oil cap washer E; oil dropper C and F*, and *thong case cap G*.

The THONG AND THONG BRUSH are shown in Fig. 138. The *thong tip A*, into which the *thong brush B* is screwed, is provided with a *rag slot C*; the *thong cord* is knotted in the *hole D* in the tip, and also in the *hole E* in the weight. In cleaning the bore by means of the thong, the brush or rag should always be drawn from the muzzle toward the breech.

ACCESSORIES.

The SCREW-DRIVER, Fig. 139, has the *large blade* A, the *small blade* B, the *spur* C, the *pin* D, and the *rivet* E. The large blade should be used for the large butt-plate screw, the butt-plate spring screw, and the guard screws; the small blade for all other screws,

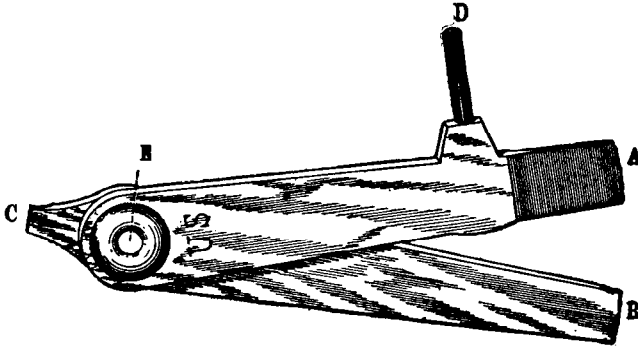

Fig. 139.

except the rear sight slide stop screw, for which the spur should be used. The pin serves as a drift in removing the butt-plate cap, floor-plate catch, and sear and trigger pins.

The BARRACK CLEANING ROD, model of 1916, Fig. 140, is made of brass rod, 0.25 inch in diameter and of sufficient length so that the bore can be cleaned from the breech end. It has the *knob* A, the *steel collar* B, and a *brass sleeve* C riveted on the end of the rod. The knob swivels on the rod between the collar and the sleeve. The other end has a socket for connection with the thong brush issued with the rifle. This rod is intended for use in garrison and camp service.



Fig. 140.

The CLEANING ROD, model of 1916, supersedes the cleaning rod, model of 1913, although the latter will be issued until the supply is exhausted. Unserviceable cleaning rods, model of 1913, are used partly in the manufacture of the model of 1916 rod and should be turned in to the commanding officer, Springfield Armory, by proper authority for this purpose.

The **NEW ROD** is a jointed brass rod, 0.25 inch in diameter and 36.187 ($36\frac{3}{16}$) inches long. It is made in four sections; the handle section with knob, Fig. 141; the second section, Fig. 142; the third section, Fig. 143; and the brush section, Fig. 144, to which is attached the thong brush issued with the rifle.



Fig. 141.



Fig. 142.



Fig. 143.



Fig. 144.

Each rod is packed in a case of olive-drab webbing and rods are issued on the basis of one for each eight rifles.

This rod and case are intended for use in field service only.

FOLLOWER DEPRESSOR.

The **FOLLOWER DEPRESSOR** is shown in perspective in Fig 145. It is used to hold the follower down, clear of the bolt, so that the rifle may be used for drill purposes in simulating fire. It comprises the *top plate* A; *wings* B; and *finger notch* C. The follower is forced

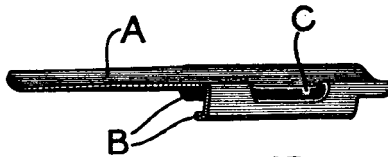

FIG. 145

down and the depressor is slipped into the magazine edgewise above the follower and is then turned so that its edges engage under the sides of the magazine opening in the receiver. Since the top plate is troughed, full clearance for the movement of the bolt is given. To remove the depressor, it is pushed down and tipped laterally by inserting the point of a bullet in notch C. When so tipped, it will be lifted out of the magazine by the follower.

ACTION OF THE MECHANISM.

(Refer to Figs. 146 and 147.)

Suppose that a cartridge has just been fired. By raising the bolt handle, the bolt is rotated to the left. Since the cocking-piece lug is held against turning by the cocking-piece groove, it is forced to the rear in the bolt by the half-cocking cam, and engages the half-cock notch. This action withdraws the striker into the bolt. As soon as the locking lugs on the bolt clear the locking cams and the safety lug on the bolt handle clears the safety lug on the receiver, the extracting cams on the bolt and receiver engage and coact during continued rotation of the bolt, to retract the latter and thus provide primary extraction. During the rotation of the bolt, the extractor is prevented from turning, by guides provided in the receiver for that purpose. Similarly, the sleeve is held against rotation by engagement with the receiver.

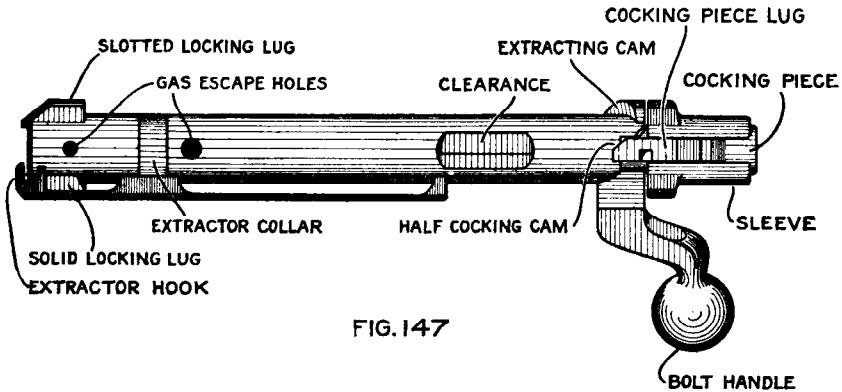

FIG. 147

The limit of turning movement of the bolt finds the locking lugs in a horizontal position. The bolt is then drawn straight to the rear, the extractor continuing to withdraw the empty cartridge case.

As the bolt begins to travel backward, the cocking piece rides over the sear nose and depresses it, the safety stud rising into the clearance provided therefor on the bolt. When the cocking piece clears the sear nose, this is raised to normal position by the sear spring.

When the rear face of the slotted (now left hand) locking lug reaches the ejector, the latter is forced into the slot in the lug and protruding through the same, in its further rearward movement, strikes the rear of the empty case and ejects it to the right. Shortly before ejection, the bolt clears the rear end of the top cartridge in the magazine, which is forced up by the magazine spring into the path of the lower edge of the bolt. If there be no cartridge in the magazine, the

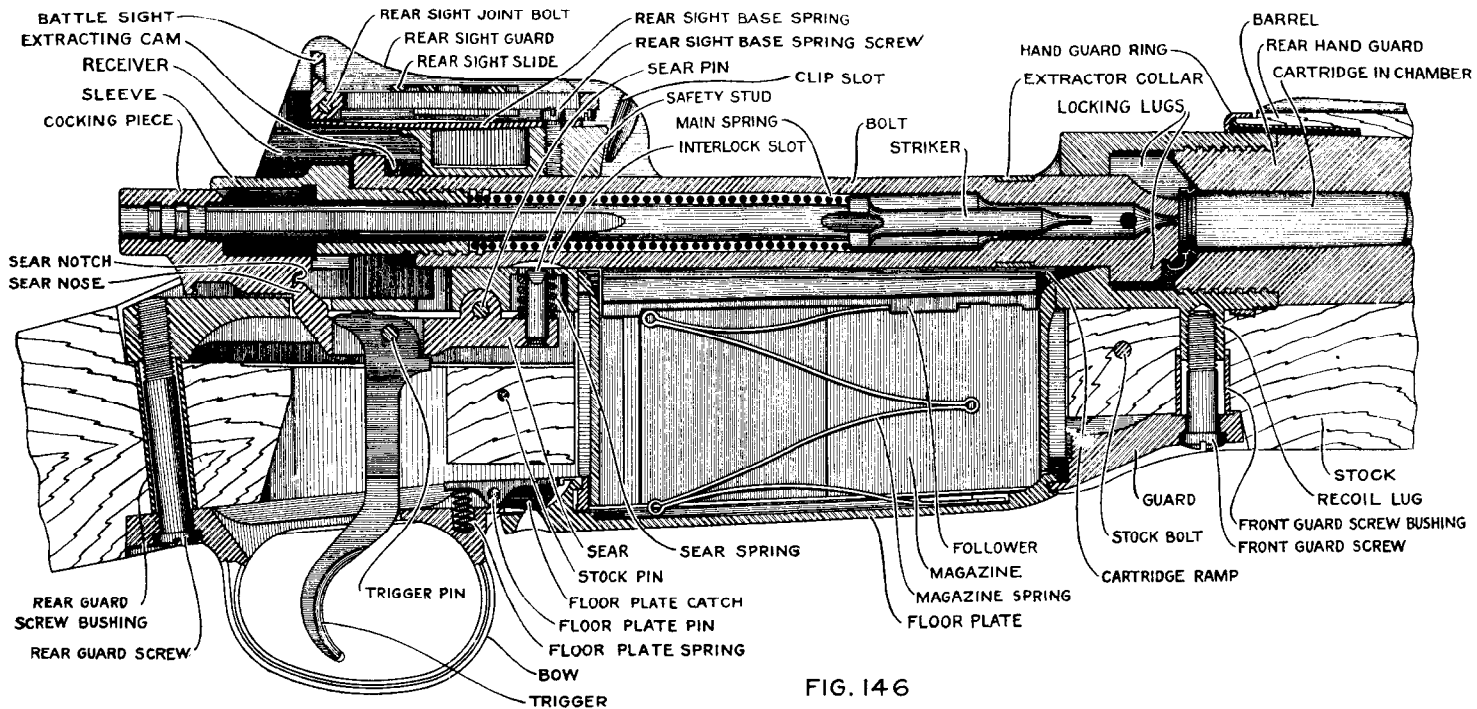

FIG. 146

follower rises so that its rib will prevent the closing movement of the bolt. This warns the soldier that his magazine is empty.

After a slight further backward movement of the bolt, this is arrested by collision of the slotted locking lug with the bolt stop lug.

Assuming that the magazine contains one or more cartridges, the forward movement of the bolt forces the topmost cartridge forward and up over the cartridge ramp. The groove in the case engages the extractor as the cartridge rises.

During the early part of the closing movement of the bolt, the ejector is pushed outward by the side of the bolt. Later, the sear notch in the cocking piece engages the sear nose, and is arrested. The bolt then slides forward over the striker, further compressing the main spring.

When the rotation of the bolt by the handle begins, the locking lugs engage the locking cams, and force the bolt home, seating the cartridge with considerable pressure, and further compressing the main spring. The rotation of the bolt restores the half cocking cam, so that it is out of the path of fall of the cocking piece lug.

The bolt is now locked, the main spring is fully compressed, and the cocking piece is held by the sear nose.

When the trigger is squeezed, the bearing of the trigger first acts on the bearing of the receiver, slowly depressing the sear nose and giving the slack. Then the heel of the trigger engages the receiver, and completes the depression of the sear nose, giving the movement known as the creep, which ends in the release of the cocking piece by the sear nose. The striker then falls under the action of the main spring, and, striking the primer of the cartridge, detonates the same.

During the depression of the sear nose, the safety stud rises through its hole in the bottom of the well, and enters the interlock slot in the bolt. If the bolt is not fully locked, the interlock slot will not register with the safety stud, and the trigger can not be pulled.

When the pressure on the trigger is relaxed, the sear spring restores the sear and trigger to normal position.

MANIPULATION BY SOLDIER.

To load.—Raise the bolt handle, and draw the bolt straight to the rear, to the limit of its motion. Place either end of a loaded clip in the clip slots in the receiver, and, with the thumb of the right hand, push the cartridges down into the magazine until the top cartridge is caught by the right edge of the receiver. Then close the bolt, and lock it by turning the handle down. The forward movement of the bolt carries the topmost cartridge into the chamber, and ejects the clip. The rifle is now ready to be fired by pulling the trigger.

Clips hold five cartridges, which is the capacity of the magazine, but a sixth cartridge may be carried in the chamber, *if the cartridges in the magazine be pressed down and the bolt be started forward over them before inserting the additional cartridge into the chamber.* Care must be taken to see that the bolt is safely started forward over the top cartridge, as the feeding of a second cartridge into the chamber by the bolt may result in the detonation of the first cartridge by the nose of the second while the bolt is open.

To eject the empty case of a fired cartridge, feed a new cartridge from the magazine into the chamber, and cock the piece, the bolt is unlocked, drawn fully to the rear, closed and locked. If the magazine is empty, the bolt will be locked in its open or rear position, by the rising of the follower.

To render the piece safe when loaded, turn the safety lock to the rear.

PRECAUTIONS.

If it is desired to carry the piece cocked, with a cartridge in the chamber, the safety lock should be turned to the rear. *Under no circumstances* should an attempt be made to let the firing pin down by hand, or by a manipulation of the trigger while closing the bolt, upon a cartridge in the chamber.

To obtain positive action, the bolt, when actuated, should be drawn fully to the rear.

If the rifle misses fire, the bolt should not be opened or unlocked until sufficient time has elapsed to assure that the cartridge is not hanging fire. Inasmuch as the rifle can not be cocked except by opening the bolt, there will be a temptation to open the bolt too soon, and it is wise to wait even a full minute and be sure.

All cams and working parts should be kept oiled to avoid undue wear.

DISMOUNTING AND ASSEMBLING BY SOLDIERS.

To dismount the bolt.—Remove the bolt from the rifle by drawing it out to the rear while pulling out the thumb piece of the bolt stop. Hook a loop of string on the dismounting hook on the cocking-piece lug, and, holding the bolt in the left hand and the string in the right, draw the cocking piece out until the lug clears the end of the bolt. (See fig. 148.) Then, by moving the right hand in a circular path counterclockwise, unscrew the sleeve from the bolt and withdraw the sleeve, cocking piece and striker from the bolt. Grasp the sleeve with the left hand, and, while holding the point of the striker against a wood or similar surface, force the sleeve toward the point of the striker, compressing the mainspring until the lug on the cocking piece clears the lug slot in the sleeve, as shown in Fig. 149. Then, with the right hand, give the cocking piece a quarter turn, in either direction, to disengage it from the striker, and draw it off to the rear. Relieve the spring

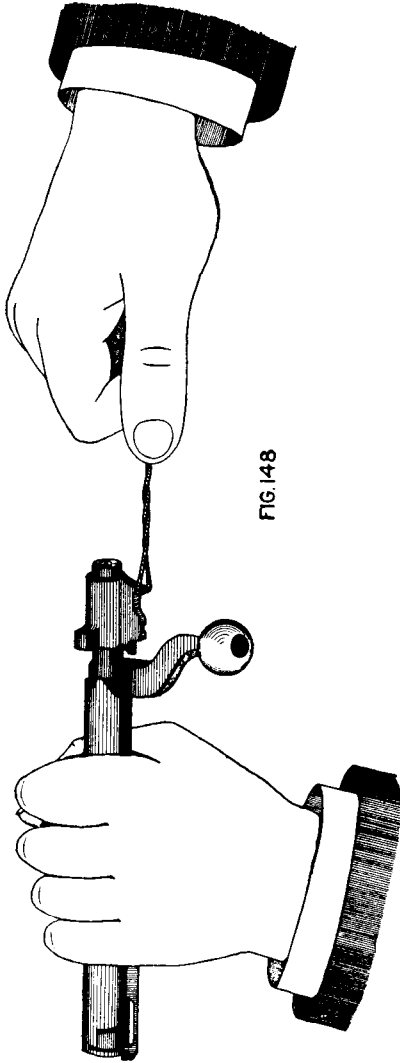

FIG. 148

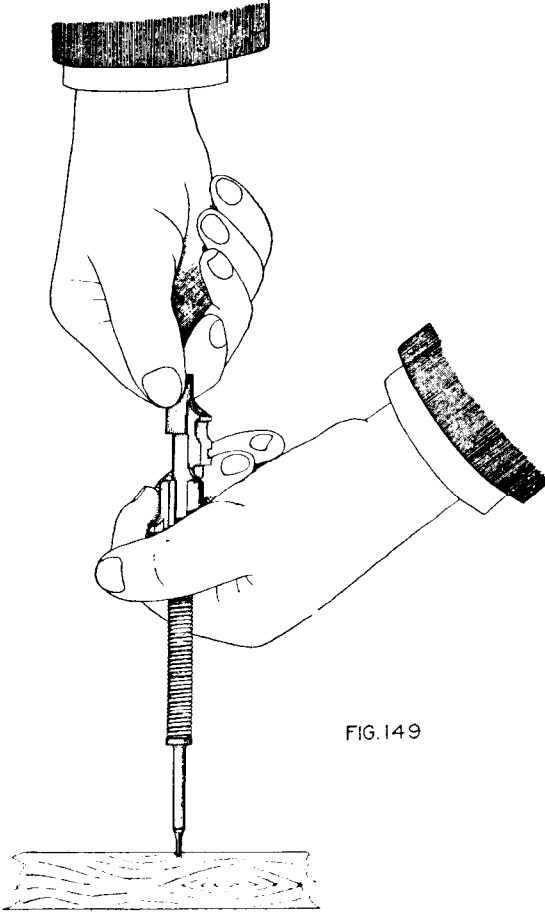

FIG. 149

from stress slowly and remove it and the sleeve from the striker, being careful that the parts do not fly from the hand. Turn the extractor so that it covers the gas escape holes in the bolt and push it forward with the thumb until it is free of the ears on the collar.

To assemble the bolt.—Slide the mainspring over the striker. Hold the point of the striker against a wood or similar surface, and, placing the sleeve against the end of the spring, with the flats in its bore registering with the flats on the striker, compress the spring by forcing the sleeve toward the point of the striker. Holding the sleeve with the spring fully compressed, replace the cocking piece on the end of the striker and lock it by a quarter turn so that its lug aligns with the lug-slot in the sleeve. Then let the sleeve return to position slowly under the action of the spring. Grasp the bolt in the left hand and start the threads on the barrel of the sleeve into the threads in the end of the bolt. Holding a loop of string in the right hand as before, hook it on the dismounting hook, and draw the cocking piece out. Then, by moving the right hand in a circular path, clockwise, screw the sleeve home in the bolt. Place the lug in the half-cock notch. Slide the extractor to place in line with the gas escape holes, engaging the undercut lug on the extractor with the ears on the ring, and lifting the hook so that the tongue will slide over the end of the bolt. Turn the extractor so that it lies over the unslotted or solid lug, and replace the bolt in the receiver. Push the follower down and close and lock the bolt.

To dismount the magazine mechanism.—With the bullet end of a cartridge, press the floor-plate catch (through the hole in the floor plate), and, at the same time, draw the floor plate to the rear. This releases the floor plate, which comes out, bringing with it the follower and follower spring.

The spring may be released from the floor plate and follower, by springing it to clear the spring stops and then withdrawing its ends from the undercuts.

To assemble the magazine mechanism.—Connect the magazine spring with the follower and floor plate by inserting its ends in the spring seats therein.

Insert the follower and spring into the magazine, and put the tenon on the front end of the floor plate in place. Then seat the floor plate by pressing it inward and forward, so that the lug on the floor plate enters its slot in the guard and is latched by the magazine catch.

The foregoing dismounting operations are the only ones to be performed by the soldier.

Selected men, properly trained, and acting under proper authority, may perform such further dismounting operations as may be necessary for repairs, proceeding as follows.