

FORGES OR HEARTHES. PLATE 7

POT FIRE

In FIG. 1 is shown a method that can be used for carbonising when a furnace cannot be obtained. This can be arranged by placing two bricks, one on each side of the fire hole, to rest the box on containing the parts to be carbonised.

Note.—Methods of carbonising are fully explained in the Hardening chapter.

The box with its contents is cased in by building four walls around it, and covering as shown. The fire is kept burning by being occasionally filled with coke. This fuel is put in through a small opening at the front, large enough to allow a loose brick to be placed in it.

POT FIRE.

PLATE 7

FIG 1

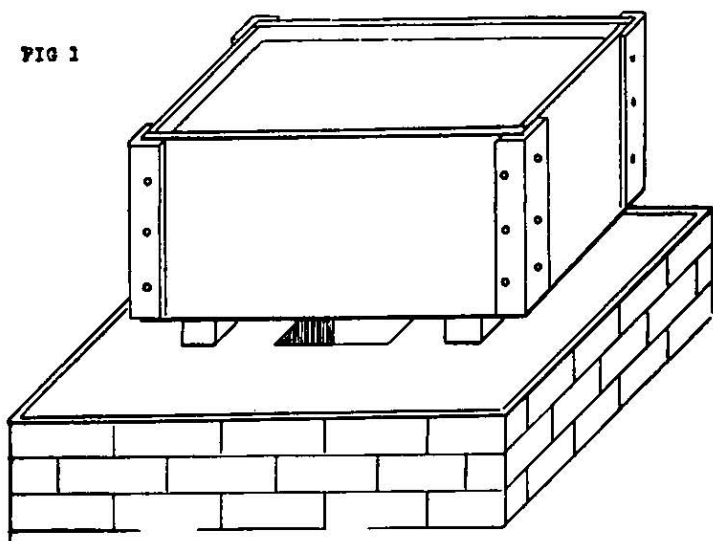
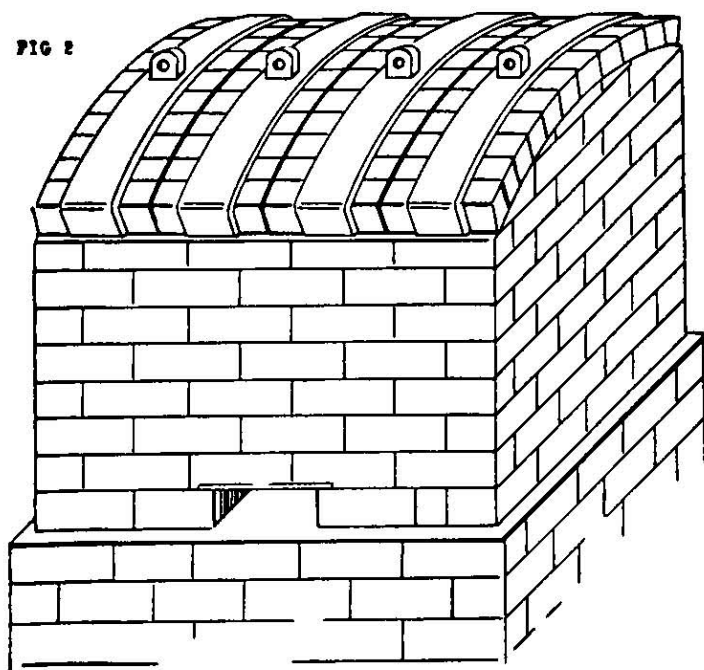

FIG 2



TOOLS. PLATE 8

ANVILS

Blacksmith's anvils. The blacksmith generally judges an anvil by its ring, a good anvil giving out a clear, sharp sound when struck with the hammer. If the anvil is defective the sound will be dull. A good anvil giving out a full volume of sound is easier to work upon than one having a dull ring. The average weight of an anvil for the smithy is 300 lb., and it is usually composed of a wrought-iron body to which is welded a hardened steel face.

To get the height in setting an anvil. The smith's finger-tips should just reach the top when standing beside it.

FIG. 1 shows an anvil set on a wood block let into the floor.

FIG. 2 shows an anvil set on a cast-iron mounting block, which is preferable, being easily moved when needed.

The practice which some smiths have of packing the anvil on their side to make it incline towards the striker is not good policy and proves a disadvantage to the smith. The anvil should be perfectly level to get the best results.

FIG. 3 shows a cast-iron swage block which is a very useful tool in the smithy. As can be seen in the illustration, the holes vary in size and shape, and around its edges are various grooves which can be selected to suit the requirements of the smith.

ANVILS.

PLATE 8

FIG 1

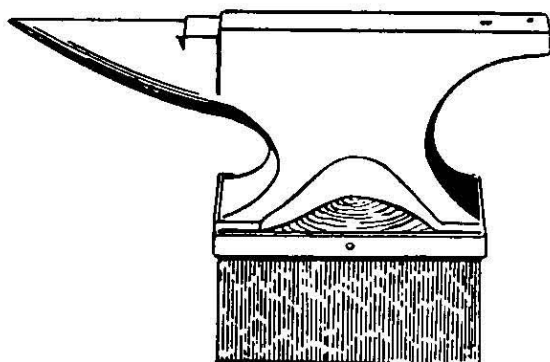

FIG 2

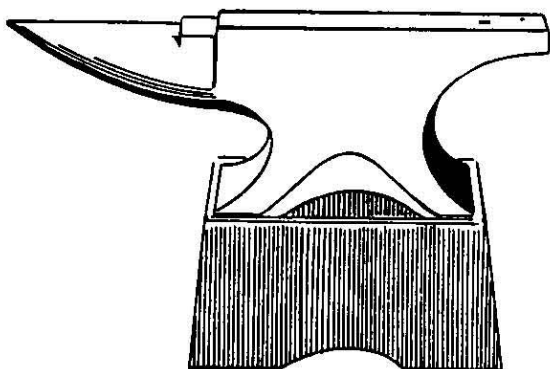
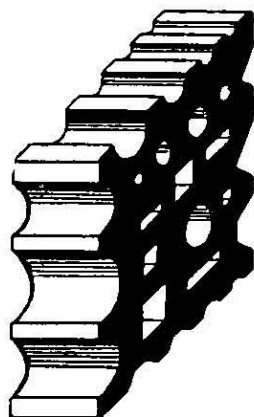

FIG 3



TOOLS. PLATE 9

HAND HAMMER

In FIG. 1 is shown a hand hammer, which is made from $1\frac{1}{2}$ -inch octagon bar.

FIG. 2 shows the first operation by punching the hole for the shaft.

Note.—When punching a hole, it is necessary to withdraw the punch after four or five blows have been struck, so as to cool the point. A little coal dust should be put into the hole before proceeding with the punching, as this will generate gas and help to force out the punch.

Next fuller, as shown in FIG. 3, on each side of the hole, then insert the mandril and flatten on the sides, as shown in FIG. 4. FIG. 5 shows a special bolster which is used to protect the shape of the eye when driving the finishing mandril in, as shown in FIG. 6.

Another method of making a hand hammer is by working a round bar in a pair of spring tools, as shown in FIG. 7. FIG. 8 shows how the hammer is practically formed when withdrawn from the tools, leaving only the hole to be punched and the hammer cut to length.

HAND HAMMER

PLATE 9

FIG 1

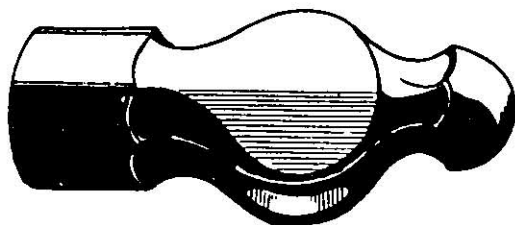

FIG 2



FIG 3



FIG 4



FIG 5



FIG 6

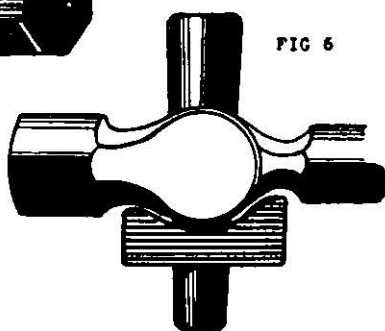

FIG 7

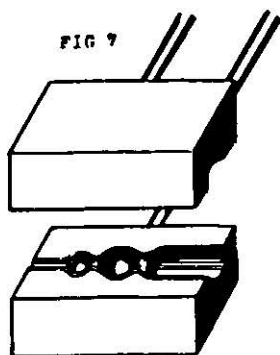

FIG 8



HAND TOOLS. PLATE 10

TONGS

PLATE 10 shows various kinds of tongs that are needed in the smithy, and almost every make of tongs has to be repeated to various sizes to cope with the different sections of material stocked.

Note.—Should a bar require to be forged and the tongs in stock do not fit the bar, the best remedy is to forge the end of the bar to fit the nearest size of tongs. The bar is then known to have a tong end.

This method should be encouraged as it relieves the smith in many cases from handling large and heavy tongs. For example, should the smith have to handle a piece of 4-inch square bar 12 ins. long to make a forging, instead of using 4-inch tongs, reduce the end down to $1\frac{1}{4}$ -inch square or to fit tongs about that size which may be in stock. The end reduced need not be scrap when cut off, as in many cases it can be used in making smaller forgings.

FIG. 1 illustrates tongs known as pincer hollow bits. As can be seen in the illustration they are made V-shaped where they grip, thus enabling them to fit square bars as well as round bars.

FIG. 2 illustrates pincer tongs to grip between two sections as shown.

FIG. 3 shows hollow bits made to grip round or square material.

FIG. 4 shows square clip tongs also made to grip square material.

FIG. 5 shows flat tongs used with a clip, to hold various widths of material.

FIG. 6 shows duck-neb tongs used for holding hoops and bars edgewise.

FIG. 7 shows hoop tongs used for holding hoops.

FIG. 8 shows angle tongs used for gripping angle iron.

TONGS.

PLATE 10

FIG 1

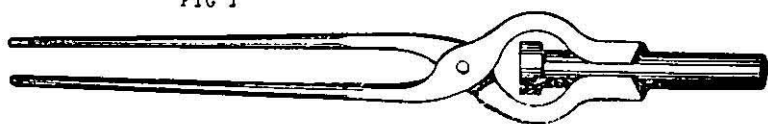

FIG 2

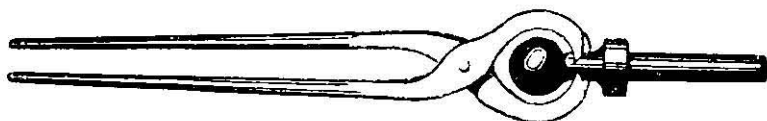

FIG 3



FIG 4



FIG 5

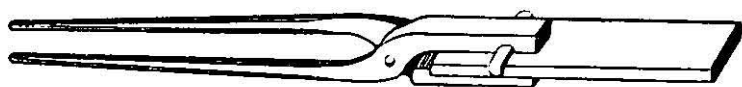

FIG 6

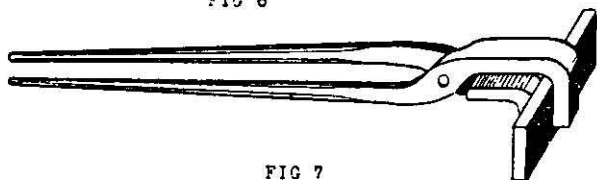
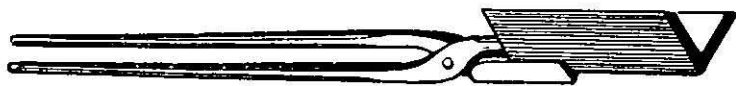

FIG 7



FIG 8



HAND TOOLS. PLATE 11

TONGS

PLATE 11 deals with another collection of tongs.

FIG. 1 illustrates pick tongs which are used for holding tapered material, such as picks, etc. The rivet in the tongs in this case is an eye bolt which is used to support the tapered point of the material.

FIG. 2 shows link tongs which are used when making links.

FIG. 3 shows chisel tongs, so-called because they are used when repairing chisels.

FIG. 4 shows T-angle tongs used for holding T-bars as shown.

FIG. 5 shows shingling tongs used for holding short pieces of material that have to be jumped under the steam hammer.

FIG. 6 shows pipe tongs which fit inside of the pipe.

FIG. 7 shows pliers or anvil tongs which are generally used by the assistant, to pick up odd pieces of hot material.

FIG. 8 shows rivet tongs used when riveting.

As can be seen in the illustrations the tong shanks are sufficiently open when gripping the material to enable a hand, to tighten and still avoid any possibility of the fingers being nipped in between.

TONGS.

PLATE 11

FIG 1



FIG 2

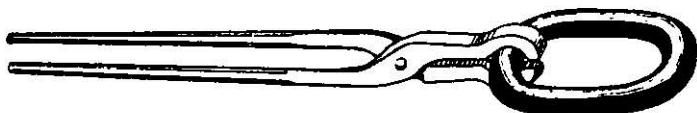

FIG 3



FIG 4



FIG 5

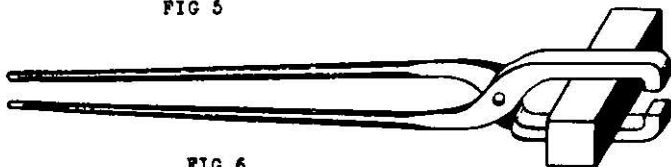

FIG 6



FIG 7



FIG 8

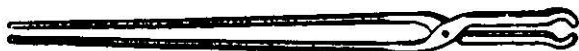

HAND TOOLS. PLATE 12

TONGS

PLATE 12 illustrates how to make tongs. When making these great care ought to be taken, as faulty tongs have been the cause of many accidents, through breaking. When making tongs avoid forging sharp angles, as these are liable to break when forging at the steam hammer, and the operator will be lucky to escape injury.

FIG. 1 illustrates the tongs to be made.

FIG. 2 shows the first operation by starting the shank of the tongs, and by following the operations shown in FIGS. 3, 4, and 5, the result is obtained.

Another method of forging tongs is to make the tong end first, as shown in FIG. 6, then follow the operations as shown in FIGS 7 and 8, and 9 which illustrates the shank ready for welding on. This method should only be adopted when there is no steam hammer available.

A method of making small tongs is to get a round bar and jump as shown in FIG. 10, then bend to shape as shown in FIG. 11. Finish off as shown in FIG. 12.

FIG. 13 shows the shape to which clip tongs should be forged.

FIG. 14 shows another method by punching a hole and cutting open, finishing by bending the ends over to fit the bar.

TONGS

PLATE 12



FIG 1

FIG 2



FIG 3



FIG 4



FIG 5



FIG 6



FIG 7



FIG 8



FIG 9

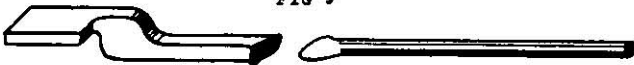

FIG 10



FIG 11

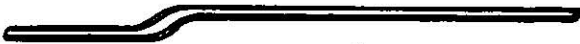

FIG 12



FIG 13



FIG 14



HAND TOOLS. PLATE 13

HAND TOOLS

PLATE 13 illustrates hand tools which are commonly used.

FIGS. 1 and 2 illustrate the blacksmith's hand hammer, which generally weighs between $1\frac{1}{2}$ lb. and 2 lb.

FIGS. 3 and 4 show cold sets, which are used for cutting cold material and handled by a shaft.

FIG. 5 shows the same cold set, handled by a rod.

FIGS. 6 and 7 show hot sets, which are used for cutting hot material, having a finer edge than that of the cold sets.

FIGS. 8 and 9 show what is commonly called a flat face, used for levelling and finishing.

Note.—FIG. 8 has rounded edges, while FIG. 9 has square edges.

FIGS. 10 and 11 illustrate set hammers which are similar to the flat face, having round and square edges. They are commonly used, and as their name signifies, they set forgings.

FIGS. 12 and 13 show top swages used when rounding material. The eye can be punched in, either way, as shown.

FIG. 14 shows a top fuller having a straight, but rounded, edge.

FIG. 15 is a top fuller having a circular and rounded edge

FIGS. 16 and 17 illustrate what are known as necking fullers, which can be seen in use on PLATE 47.

FIG. 18 shows a round-faced fuller.

Swages and fullers ought to be stocked in various sizes.

HAND TOOLS.

PLATE 13

FIG 1



FIG 2



FIG 3



FIG 4



FIG 5



FIG 6



FIG 7

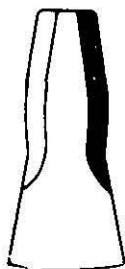

FIG 8

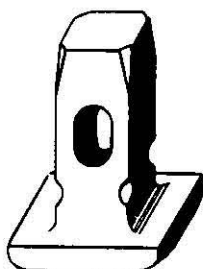

FIG 9

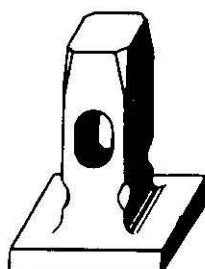

FIG 10



FIG 11



FIG 12

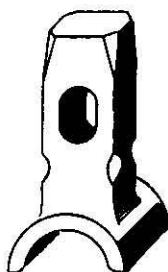

FIG 13

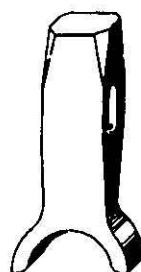

FIG 14



FIG 15



FIG 16



FIG 17



FIG 18

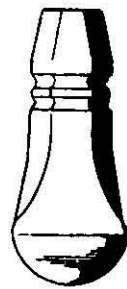

TOOLS. PLATE 14

ANVIL TOOLS

It is essential that the smith be well versed in the various uses of the many tools common with his trade. The very variety of smith work itself calls for the constant necessity of some new design of tools, and the smith with an inventive turn of mind will find full scope for his ability here.

Anvil swages, as seen in FIGS. 1 and 2, are made in various sizes, from $\frac{1}{4}$ in. to 4 ins., with a top swage to go along with each one. They are used in rounding material to any given size that may be required. The majority of anvil tools can be made from tong ends which have been cut off the end of bars.

Note.—When making tong ends it is advisable to draw them down to suit any tool that may be required.

FIG. 3 shows a bottom fuller, which can be seen in use on PLATE 17.

FIG. 4 shows a bottom fuller with a stop forged on. This is to keep the forging from rolling off when fullering.

FIG. 5 shows a tool known as a saddle, and can be seen in use on PLATE 16.

FIG. 6 shows a bending link. See PLATE 16.

FIG. 7 shows a cutting tool which is made to come flush with the side of the anvil. This tool should be made of steel that can be hardened. See PLATE 16.

FIG. 8 shows a fork tool which is used for bending. See PLATE 16.

ANVIL TOOLS.

PLATE 14

FIG 1

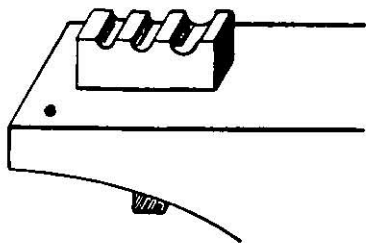

FIG 2

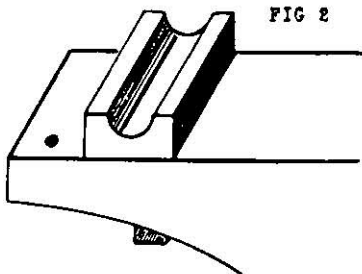

FIG 3

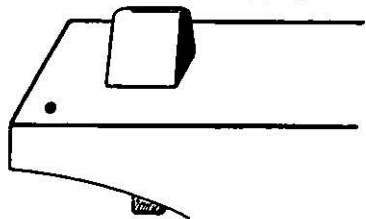

FIG 4

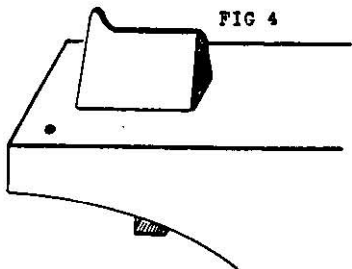

FIG 5

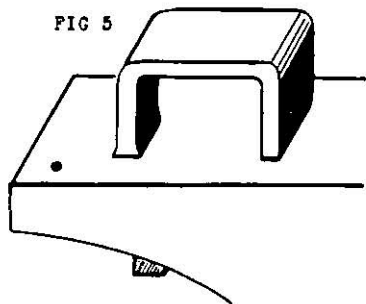

FIG 6

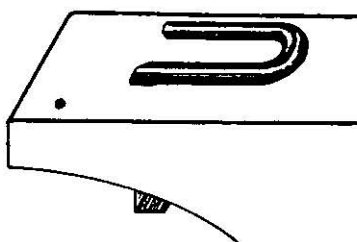

FIG 7

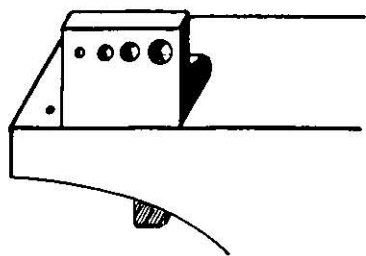
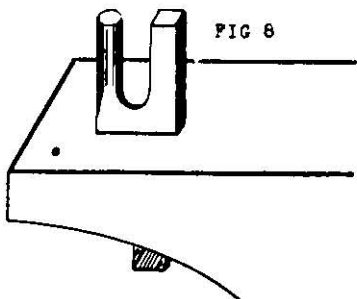

FIG 8



TOOLS. PLATE 15

ANVIL TOOLS

FIG. 1 shows what is termed a bolt swage, so called because it is used for making bolts. It has a groove to round the bolt, and a deeper groove, which acts as a bolster when welding the head of the bolt. It also contains a hexagon groove for shaping the head as shown. A tool so made saves the trouble of changing at each operation, as is the case with single-grooved swages.

FIG. 2 shows a T-swage, so called because it is used for swaging T-pieces. See PLATE 16.

FIG. 3 shows an anvil cutter used for cutting small bars.

FIG. 4 shows a bottom radius fuller, which is explained fully on PLATE 17.

FIG. 5 shows what is termed a hexagon swage used for shaping bolt heads.

FIG. 6 shows a V-swage used for shaping square corners. See PLATE 16.

FIG. 7 shows a link tool used for welding links. See PLATE 16.

FIG. 8 shows a block tool, which is used when the anvil is too wide.

ANVIL TOOLS. PLATE 18

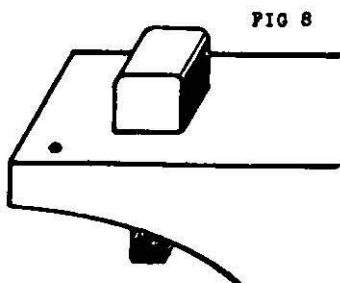
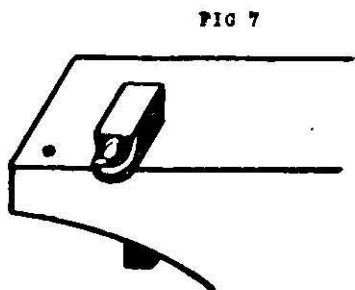
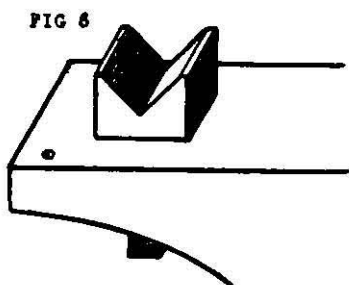
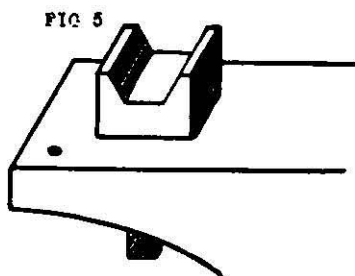
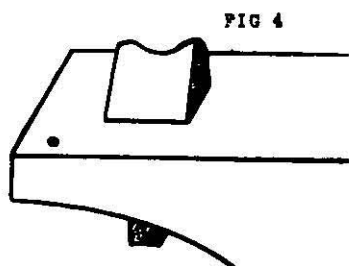
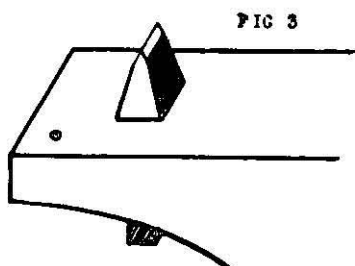
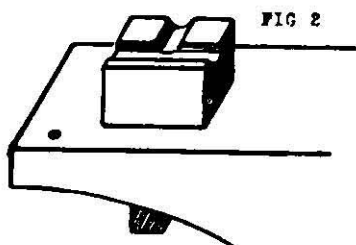
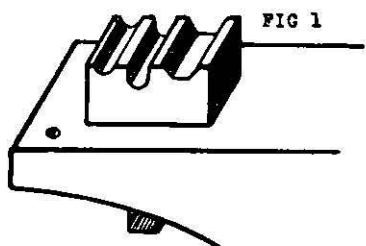

TOOLS. PLATE 16

ANVIL TOOLS

PLATE 16 illustrates the tools which have previously been mentioned in use.

In FIG. 1 will be seen a saddle generally used for such forgings as double eyes.

FIG. 2 shows the method of bending a bar at right angles by using a bending link.

FIG. 3 shows the method of using the cutting tool.

FIG. 4 shows the fork tool in use.

FIG. 5 shows the bolt swage in use.

FIG. 6 illustrates a T-piece between top and bottom T-swages.

FIG. 7 shows one method of using a V-swage with a fuller to shape square corners.

FIG. 8 illustrates a method of welding a link by using a link tool.

ANVIL TOOLS.

PLATE 16

FIG 1

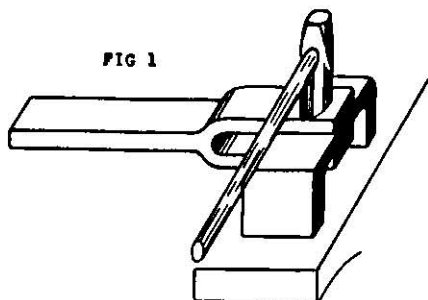

FIG 2

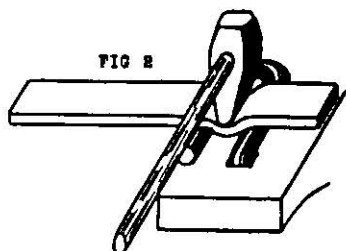

FIG 3

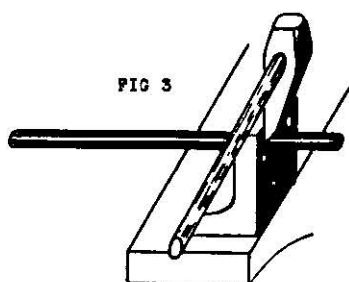

FIG 4

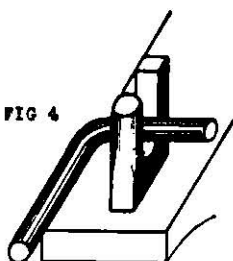

FIG 5

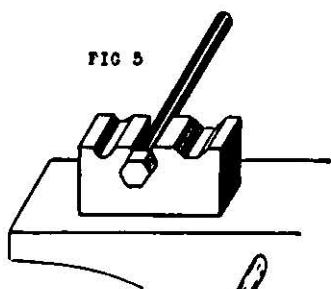

FIG 6

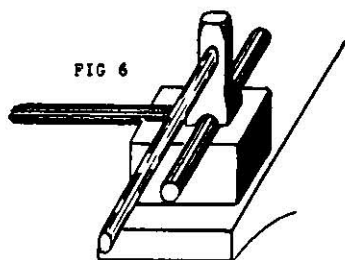

FIG 7

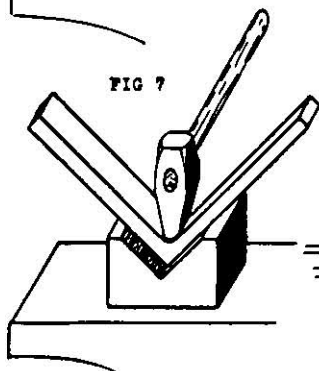

FIG 8

