

poortour.com/build/spud_guns

http://www.poortour.com/build/spud_guns/

These are my current spudguns. I have built these three so far, and I have some sketches of guns to come in the future.

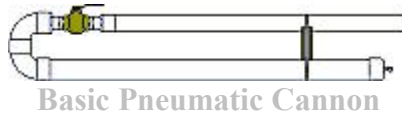

Basic Pneumatic Cannon

This is a great gun to start with for beginners or those venturing into pneumatics. Many high-power cannons are modified versions of this.



Electronic Solenoid Valve Cannon

This gun is the simplest electronically actuated air cannon. I recommend this for skillful hobbyists. Many advanced designs come from this concept.



Sniper Rifle

An entirely new approach, this gun is frightening. Launching small bore projectiles through a breech, it is menacing to behold, and a beauty to see.



Breech Loader Barrel

This modified barrel loads just like a regular breech loadin rifle. It uses modular 1" connections and works best with the rifle.

This is a basic pneumatic cannon, an excellent starting point for the novice of PVC mechanics. This cannon uses a simple twist-open ball valve that gets the job done, no need to mess with electronics. I built this cannon for my dear friend Connor, in fact these air guns are what brought us together, the man is incredible. He used this cannon in a play he directed, *The Cenci*. This cannon performs well and is rugged.

MATERIALS.

- 1" Pipe (short sections for use as nipples)
- 1 1/2" Pipe
- 1 1/2" Coupling
- 1 1/2"x1" Reducing Bushing
- 2" Pipe
- 2" Street Elbows (Male and Female connections)
- 2" Endcap
- 2"x1" Reducing Bushing
- 1" to Male Thread x2
- Tire Valve
- 1" Ball Valve
- Large block of wood and tie strap for spacer

ALL PIPE IS SCH 40!

DO NOT USE DWV PIPE!

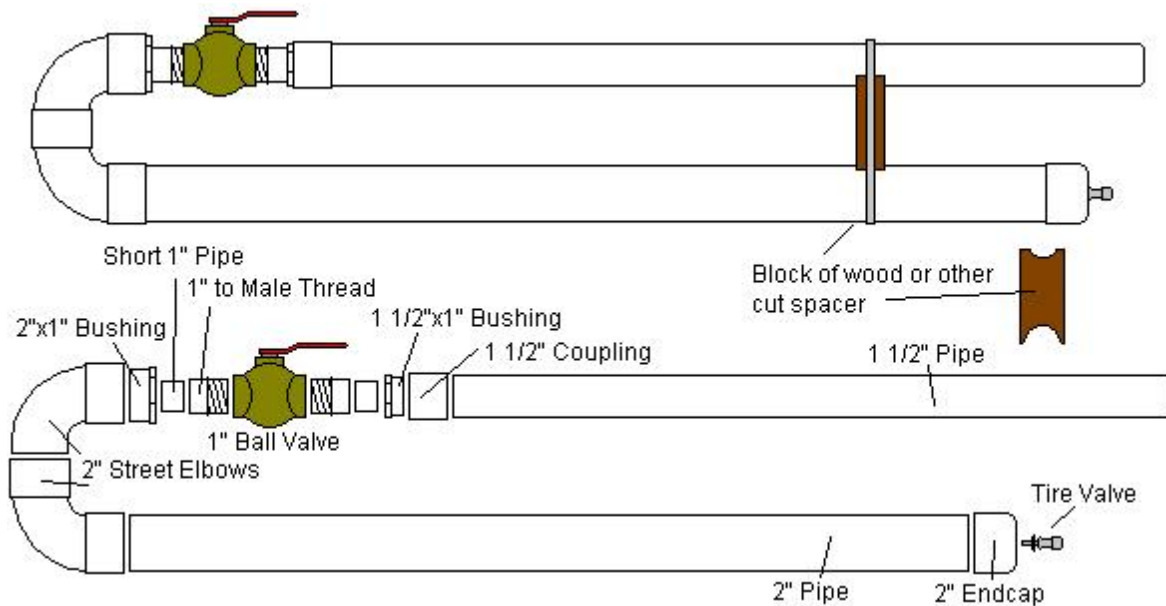

ASSEMBLY.

This cannon is very simple to build. The 2" Chamber should be cut around 4 feet, but can be as short as 3 feet and still perform well. It is a matter of preference. The barrel should also be around 4 feet. Drill a hole for the tire valve and attach it to the endcap, before it is glued in place. When all pieces are arranged, prime and glue. Let them sit overnight or you risk destroying the seal of the glue.

Adaptations of this cannon abound on the Internet. One cannon is 10 feet long and shoots 3" wide bean cans of concrete!

poortour.com/build/spud_guns/electronic.html

This launcher is the typical pneumatic type. It is often referred to as over-under type or bazooka (because of its shape and launch position). Most electronic pneumatic launchers are modifications of this design, incorporating different barrels, elbows, and pipes. The idea for this launcher undoubtedly came from the [Not how to build an air cannon](#) page. The following is my design.

THEORY OF OPERATION.

This launcher has a compression chamber. Air is pumped into this chamber by means of a tire valve. A sprinkler solenoid valve stops the flow from the chamber into the barrel. When the desired pressure is reached, the valve is opened by means of an electronic circuit. Exact pressures can be reached for each shot by measuring with an ordinary tire-gauge. Air then rushes out of the chamber, through the (often small) valve, and into the barrel, pushing the projectile out, to great joy.

MATERIALS.

48" SCH 40 1 1/2" PVC Pipe
45" SCH 40 2" PVC Pipe
1' SCH 40 1" PVC Pipe
1 1/2" to 1" Reducing Bushing
2" to 1" Reducing Bushing
1 1/2" Coupling
2" Coupling
2" Endcap
1" PVC to Male Thread X2
Milton Chrome Tire Valve
RainBird Solenoid Sprinkler Valve
Large Hose Clamp and Block of Wood
Electronics Box (See Below)

ALL PIPE IS SCH 40!

DO NOT USE DWV PIPE!

ASSEMBLY.

First cut all pieces to length and clean the ends to be glued. Drill a hole in the end cap for the tire valve and screw it in place. Also, taper the firing barrel to shave the spuds. Glue all red areas, and the blue areas inside the couplings. Obviously, do not glue the threads. Glue the pipes to the couplings and let them sit overnight. When ready, screw the pipes to the valve. Teflon tape can be used to insure an airtight seal, however be careful not to tighten too much, or the pipes will be very hard to get off (*I had my pipes break due to a fall, and the remaining threaded pieces were extremely hard to grasp. Usually once around the male threads with the tape is good*).

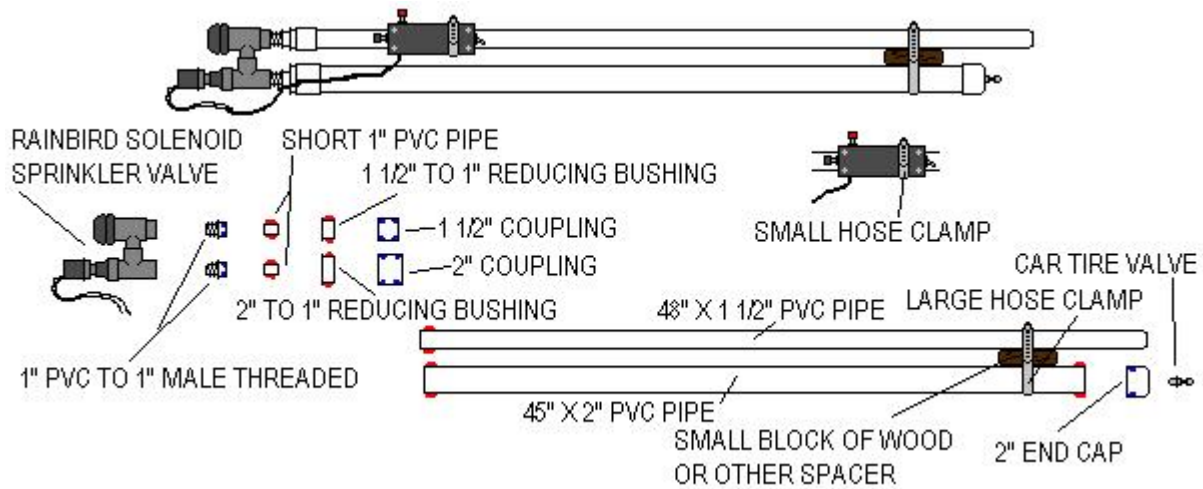

The compression chamber is 2" x 45". The control box features a triple safety: a labeled on-off toggle switch, and two buttons which must be pressed simultaneously to get the cannon to fire. The barrel I use most is a 1 1/2" x 48" barrel. I tapered the end to help cut the spud into shape. I also have a two inch barrel.

The tire valve to fill the chamber is a MiltonValve. To the right is a photo of the package and valve. I picked this up at an auto store for 5 bucks. The valve is chrome and one that you bolt in place. The washers and nuts are included, you just drill a tap hole on the endcap of the chamber for the valve.

To make the control box, use Radio Shack parts. Assemble it as shown in the cannon plans, or modify switch location to suit your preferences. This is just a guide, and two switches are not necessary, one is sufficient. All joints should be soldered for maximum efficiency. The valve operates at 24 volts DC so the three 9 volts are ample power, being the valve is opened for only a few seconds at a time.



Chrome Tire Valve.

CIRCUIT MATERIALS.

These are the parts for this circuit. The links go to the part information on the Radio Shack Website.

Momentary switch, RS# 275-609
SPST Switch RS# 275-602
Project box RS# 270-1804
9 volt battery clips RS# 270-325

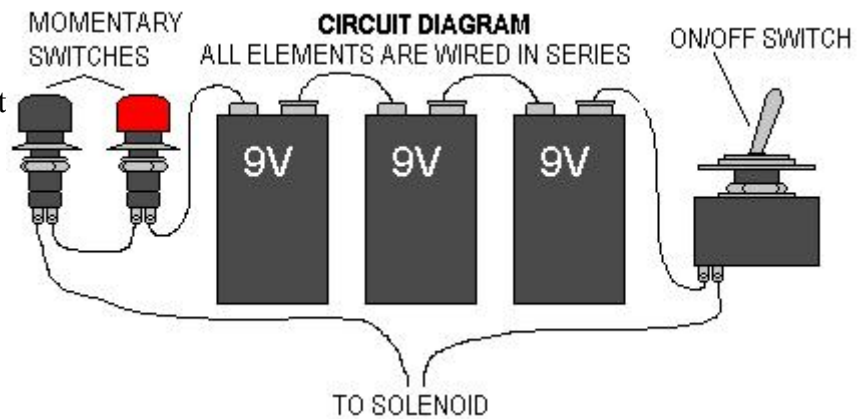

Set the control box against the firing barrel and use a small hose clamp to secure it. Then insert a block of wood or something similar near the business end of the launcher and use a large hose clamp to secure them.

Altogether, this cannon cost approximately \$47. \$12 for valve, \$15 for pipe (sold in 10' sections) and fittings, and about \$12 for batteries and electronic parts. It has been a while since I built this, so I cannot give you a more accurate price guide yet.



The Firing Control Module.



The completed launcher in action.

poortour.com/build/spud_guns/sniper.html

This launcher is incredible. It's design and look alone is intriguing and intimidating enough to give any potato the willies. It operates like other pneumatic launcher, except this is built to simulate a rifle. Air flows through the angled stock, from a chamber underneath the barrel. A breech loader has been added for ease of loading projectiles.

The concept for this gun came from [Xinventions](#). The following design is my adaptation and advancement of the previous design.

MATERIALS.

Pipe can be bought in 5' sections.

3/4" Pipe

1" Pipe

2" Pipe

3/4" 90 deg. Elbow x3

3/4" 45 deg. Elbow x6

3/4" Tee x2

3/4" to 1" Male thread

1" to 3/4" Bushing

1" to Female thread

1" to Male thread

2" x 1" Bushing

2" Coupling

2" Endcap

Tire Valve

1" RainBird In-line solenoid sprinkler valve

ALL PIPE IS SCH 40!

DO NOT USE DWV PIPE!

ASSEMBLY.

The stock assembly is the main part of the gun. I cannot give you accurate measurements, as I built it to fit my large physical profile. I will post better measurements when I find my schematics again. Stoppers (pictured below) are not necessary. Don't worry about them. Simply glue the stock pieces as shown. Feel free to change the position/length of the stock and handle to suit you.

I made the chamber 2' 6". I felt this allowed for ample volume while maintaining a low profile. Great volume is not so necessary in this gun, as you are shooting smaller, lighter projectiles (not large potatoes, although with another barrel you could).

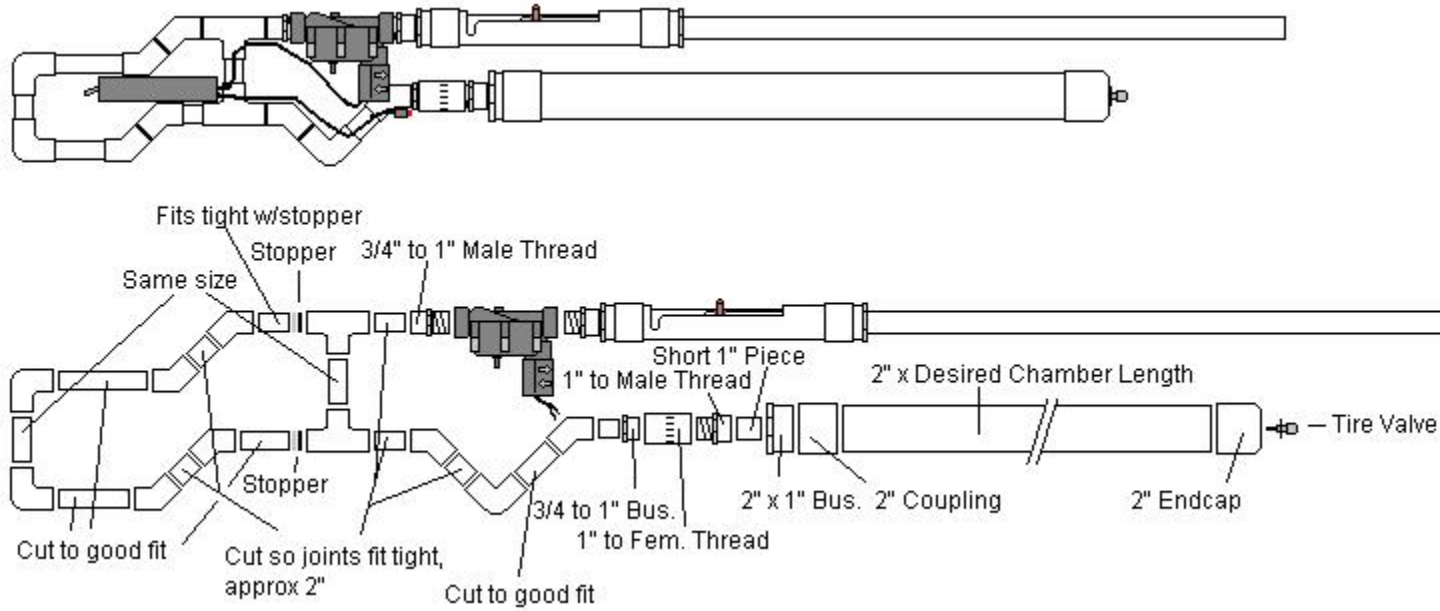

For construction of the breech loading mechanism, please see the [breech loader mod](#) page. Construction of the firing mechanism is seen below, or for more detailed parts, see the [ESVC-01](#) page. Wire the electronics like so. More plans to come later. Place the momentary switch in its obvious location, you will need extra wire to do so. I just duct taped mine in place (oh yes).

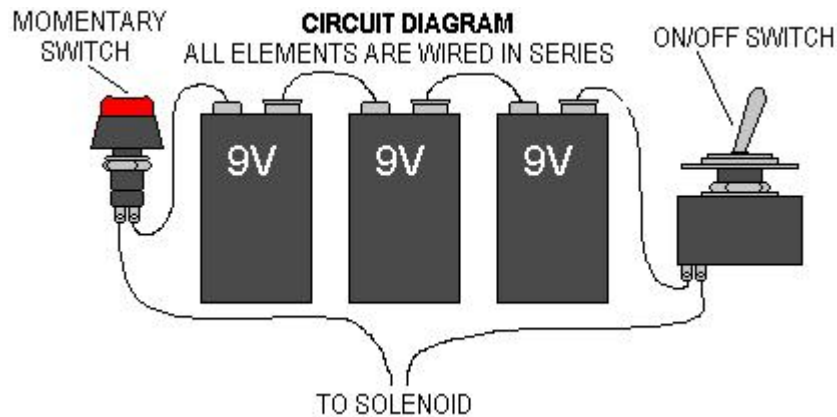

I am working on other plans for a more compact version of this gun, or one with rapid-reload capability. Stay tuned for updates, and I am always happy to give advice or to chat.



Yes. Oh yes.



Vietnam Vet, Postal Carrier, American Hero.



Where does he get those wonderful toys?

This barrel modification is used primarily in conjunction with the PSR-01. This device allows for easy breech loading of small bore projectiles into the pneumatic launcher, and operates exactly like other breech loading rifles. This unit has an entire barrel as well, it is not an add-on like sound suppressors, as seen on other web pages. I give credit to Xinventions for the idea, and the following is my original design.

MATERIALS.

16" of 1 1/2" Pipe
40" of 1" Pipe
Small hose clamp for 1" Pipe
Screw and wooden dowel for lock
1 1/2" Bushing x2
1 1/2" Coupling x2
1" to Male thread
Washer (information below)

ALL PIPE IS SCH 40!

DO NOT USE DWV PIPE!

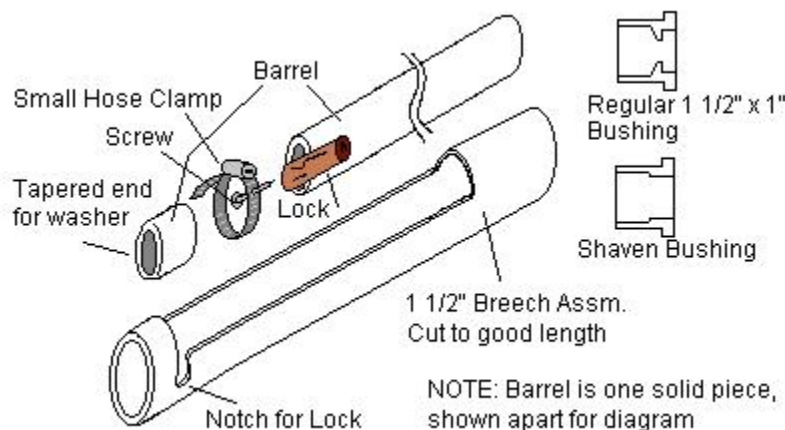

ASSEMBLY.

First off, you need a 40" section of 1" pipe, this is for the barrel. Taper one end to a smooth finish at about 45 degrees. This is to make a tight fit with the washer. Find a washer that fits tightly inside the 1 1/2" pipe and will seal correctly with the barrel. This is important to secure an airtight seal. (*I and others who have built this gun have incredible difficulty forming a good seal. As a result of my design, the vibration from the air against the washer creates a deafening honking sound, not very sniper-like. Any ideas here would be greatly appreciated.*) The washer should go between the first bushing and the coupling towards the end of the barrel that screws into the solenoid valve (see below). For the bushing towards the front, you will have to shave off the pipe stop with a Dremel. Make sure it is a good enough shave so the barrel can slide in and out of it with ease.

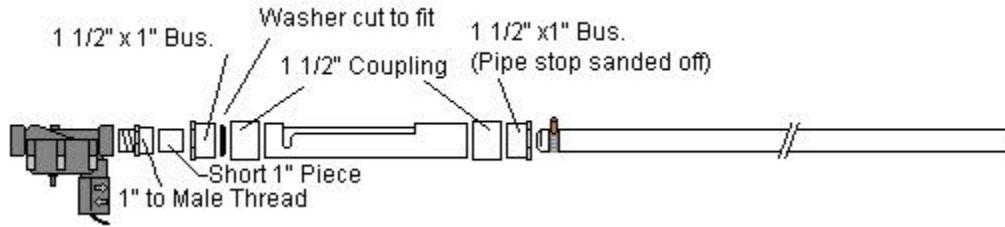

The 1 1/2" pipe is cut as shown with enough room on top to allow access to the barrel. The section is about 1 1/2" from one end, and runs the length of the breech for 8 1/2". Use a Dremel tool to cut the opening, or alternatively, drill a section large enough to fit a small saw blade in and cut the hole with a saw. The notch should be as wide as the piece of wood you use for the handle. See notch and handle in pictures below. Once the couplings and bushings are glued and dried in place slide in the barrel, tapered end first and find where the clamp should be so the barrel fits tight with the washer. Just glue on the remaining threaded piece that screws into the valve to make it modular with your guns.



Breech closed.



Breech open.

This barrel allows for creative uses in ammunition including carrots, paper cones, marshmallows, batteries, dowels and more.