

10

BLUE BOX

Multi-frequency Encoder

Approximate Construction Time: 3 - 4 Hours

Approximate Construction Cost: \$35.00

The Multi-frequency Encoder described here is a useful tool in modern telephony. With the Touch-Tone matrix, as shown here, it can be used for high speed dialing, remote control of answering devices, keying radio relay and Auto-patch devices and even to access computers. The flexibility of this unit allows it to be adapted to a variety of paired and discrete tones as your needs require.

The new *Intersil 8038CC Function Generator* forms the basis of the *Multi-frequency Oscillator*. The 8038 waveform generator is a monolithic integrated circuit capable of producing sine, square, triangular, saw-tooth and pulse waveforms of high accuracy with a minimum of external components. This IC utilizes advanced monolithic technology, such as thin-film resistors and Schottky-barrier diodes. By varying an external resistor, one can change the output frequency of the 8038. Unlike earlier designs, which used *phase-shift* oscillators, the distortion remains at a low 1%. Additionally, this design requires only two oscillators, rather than the normal seven. The diodes route the V_{cc} voltage of 12 volts to different trimmer pots for the various tones.

The pots should be 10 or 20 turn trimmers, rather than single turn pots. This is due to the inability of the single turn variety to be tuned accurately. Discrete resistors are also not applicable, since they are not available in the values required, and cannot be adjusted.

The two 8038 oscillators draw 20ma, so it is wise to keep the unit off when not in actual use, this will greatly extend battery life. The two 8.4 volt batteries will provide a good power source, but need to be regulated to provide a steady 12 volts. The LM 340K or LM340T (identical except for shape) are simple and easy to use. Having only three leads—input, ground and output, they are a good example of the advances in solid state technology. Mercury batteries are suggested because of the way in which they discharge. They hold their voltage for a long period, then drop off quickly. Other types of batteries discharge in a slow downward curve and are an unstable voltage source.

Germanium diodes are recommended over silicon to minimize the differences in voltage drop.

(Continued)

Amplification is provided by the 741 Op Amp. It draws 5 volts from the 8038s through the two 100K resistors. The unit provides good output volume for driving other tone decoding circuitry.

Calibration is not difficult, because the two 8038s plug into IC sockets. By simply inserting only one 8038 at a time, the trim pots associated with it may be easily calibrated using a frequency counter or oscilloscope. After the tones for one 8038 are set, remove it and plug in the other, and repeat the process.

The unit is shown with a Touch-Tone 4x4 matrix, however, any matrix or combination pattern may be used with equal success. In our plan we have also shown one unpaired tone. In the case of such an unpaired tone no diodes are required. The unit may be expanded to produce more tones as desired by adding the necessary trimpots and diodes.

If the suggested keyboards should be difficult to find or beyond your budget, you can produce your own in the following manner. For each tone, or tone pair desired purchase a single pole, momentary contact, normally open switch. These switches (16 in the case of a full Touch-Tone matrix) are mounted in the cover of your case and the appropriate label may be placed under each one. After the switches are mounted, one terminal of each one should be connected in common and fed to + voltage.

It is recommended that a telephone type speaker be used (the earpiece found in a regular telephone) to provide the least distortion. If it is desired to couple this unit to an 8 ohm speaker, a 500/8 ohm transformer will be required.

Use of the encoder is quite simple. The desired number is dialed in the normal manner. After the called number has answered, the earpiece speaker of the encoder is held tightly against the mouthpiece of your telephone and the desired tones transmitted. The encoder may also be used to Touch-Tone a call from a regular dial phone where the phone is connected to tone decoding equipment at the central office. To do this simply lift the handset, wait for dial tone, place the encoder speaker to the mouthpiece and punch out the desired number. □

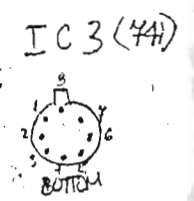
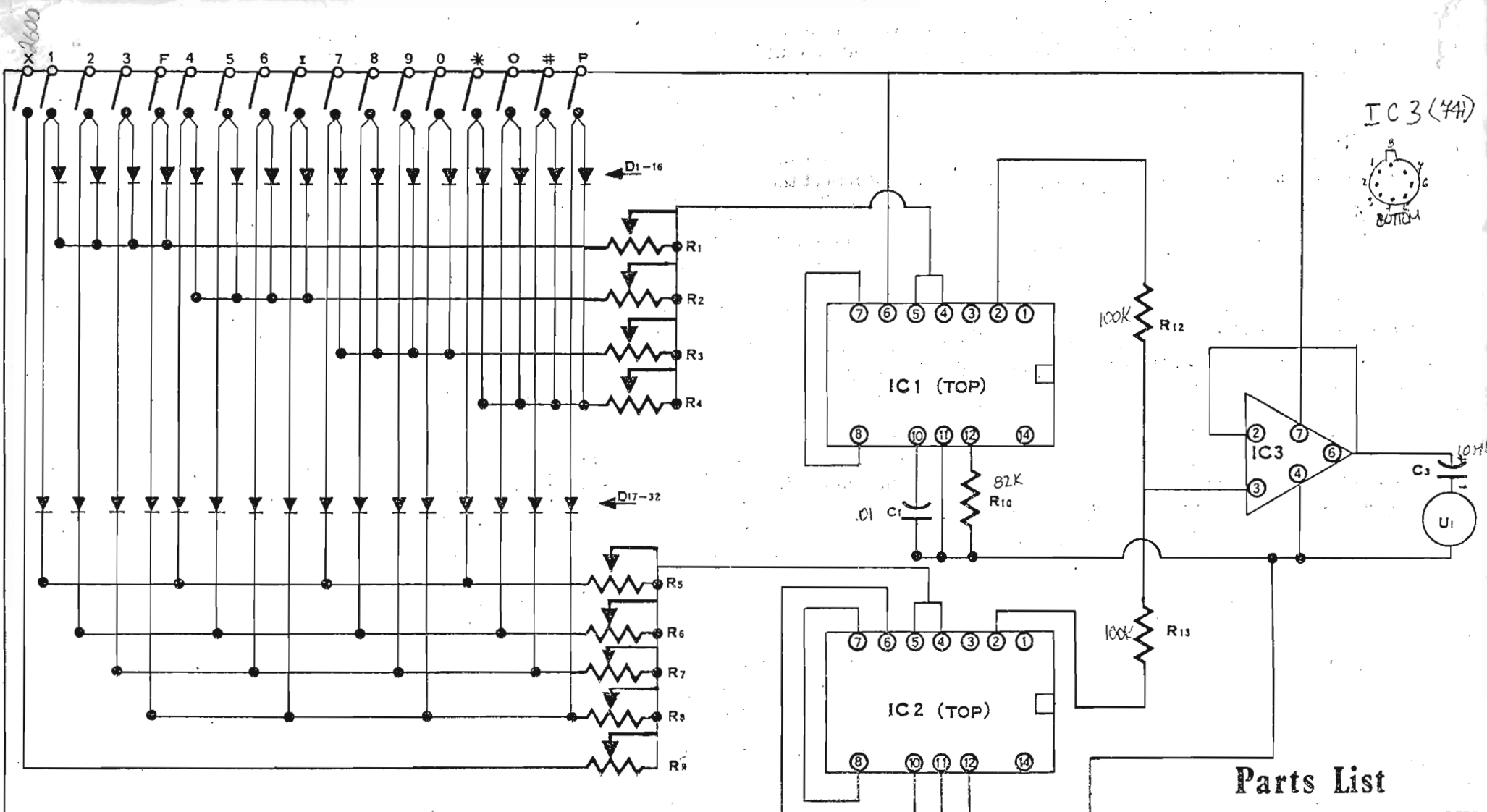

Parts List

- D1 - 32 - Germanium diodes 50 PIV
- R1 - 9 - 25k ohm 20 turn Trimpot
- R10 - 11 - 82k ohm resistor
- R12 - 13 - 100k ohm resistor
- C1 - 2 - .01 mfd. Disk Capacitor
- C3 - 10 mfd. 25 volt electrolytic capacitor
- C4 - .1 mfd. disk capacitor
- C5 - .22 mfd. disk capacitor
- IC1 - 2 - Intersil 8038
- IC3 - 741 Op Amp
- IC4 - LM 340 T voltage regulator
- U1 - standard telephone type speaker

