

**AUTO-COMBO RED-BLUE BOXES**



**JULY 1978**

**NO. 51**

As Milo said in his letter, the box is made up of three sections : front panel with keyboard, memory and logic board, and oscillator/amplifier. The front panel is pretty explanatory. The only comment I have is that the diodes be silicon. In order to conserve space try using dual diodes (Motorola HEP R9002). The other two boards use digital logic. The first, thing you should remember is that the pin connections for power are not shown in the schematic. On most 14 pin chips pin 7 is ground (-) and pin 14 is positive (+). On most 16 pin chips pin 8 is ground (-) and pin 16 is positive (+). The following chips are used for external logic :

- Quad.NAND gate : 4012
- NAND gates : 4011
- NOR gates : 4001
- BUFFERS : 4010
- INVERTERS : 4009

The 4004 divide-by-128 chip is now a 4024 chip. It performs the same function as the 4004.

The NH0002 op-amp is now numbered LH0002. This chip is manufactured by National Semiconductor. Data on these can be obtained from the Linear Data Book by NS, available from your local Rip-Off Shack. On the memory/logic board pins 2 and 9 are bussed. In other words all the pin 2's and all the pin 9's are connected together.

The capacitors that are not marked leave me in the dark! I'm going to try a .001 or a .0015 mfd. and see what happens. If anyone gets to finish this before I do, drop us a line and let us know what you found. Otherwise I'll let you know what I find out.

Just as a hint, I'm planning on making printed circuit boards for the keyboard and osc/amp board and using wire wrapping on the memory and logic board. For an applicable idea look in the Sept. 1977 issue of BYTE magazine.

NOTE : These notes were made before actual construction of my own box. The fotos that came with Milo's letter showed an actual box. These notes and the additions made to the schematic are presented to aid in the construction of the box. As I have not built my own box I cannot vouch for the validity of the additions or the notes but they are a reasonable assumption based on study of the schematics and consultation with the RCA COSMOS Date Book. If anyone has corrections or comments please send them in to TAP and Tom will forward them to me.

Before I leave I'd like to make a personal request : Milo Fonebill, will you please get in touch with TAP? !!! I'd like to know how close I came.

Thankx,

Wizard

**EDITOR'S NOTE :** The above mentioned letter from Milo Fonebill was reprinted in TAP #47 without the schematics because I realized that they were incomplete and I didn't want to publish them until some of our technophreaks had a chance to go over the circuitry and make additions and/or corrections. Since issue #47 was published, I have been besieged by requests from readers for the Milo Fonebill schematics. Rather than go through the expense of photo-copying these schematics every-time a reader wants them, I've decided to publish them , errors, mistakes, omissions and all. The four schematics on the inside pages of this issue are the most corrected up-to-date copies available at this time. I will continue to update these schematics in future issues of TAP as the additions/corrections are made known to me. Some of you TAP technophreaks were bitching that the last couple of issues lacked technical articles so here's a golden opportunity for you to blow the dust off of your test equipment and rise up to the challenge. The first reader who sends me a corrected working schematic of Milo Fonebill's programable Blue Box will receive a one year free extension of their subscription. Fair enough?

1

By now all of our subscribers should have received their copy of TAP # 50, our special double edition 7th anniversary issue. That issue was, in my opinion, one of the best issues in a long time. I'd like to be able to say that TAP readers responded to my plea for info, articles, and columns but that has not happened. All of the articles, columns, and info in issue # 50 were obtained either by brow beating some of our regular office "irregulars" or by digging through our files for any tidbit that we could use. It was a tedious job! To add insult to injury, TAP has been going through some VERY rough times! The long delay between issues 46 & 47 and 48 & 49 was the result of a gigantic fuck-up by the individual responsible for getting our mailing labels printed up. Issues 48 & 49, which were mailed out on March 23, 1978, had been sitting at the TAP office collecting dust since November 23, 1977! That four month rest period between issues was deadly! Our mail, renewals, new subscriptions, and financial condition went from bad to worse! Things got so bad that our rent check bounced and I was forced to pay it out of my own pocket! At this point in time I was personally going through a financial crisis of my own and the thought of having a TAP albatross around my neck was enough to give me serious thoughts about folding TAP! After all, I reasoned, three years of busting my balls on TAP was enough! Let some other ass hole take it over! Who needed it?

I made plans to close up the TAP office at the end of the year. I wrote to my very close TAP friends informing them of the decision that I had made. The response was immediate. "Don't do it!!!" Words of encouragement were nice but they did little to ease the financial crisis. It would take an act of God to keep TAP going. And that's what we got! I have long held the notion that God is on OUR side (supported by the recent subscription to our publication by a VERY prominent Catholic publication). HE must have reasoned that if ever HE was to save TAP, now was the time to act! HE works in mysterious ways and HIS way this time was in the form of a much needed plug in the April 1978 issue of HIGH TIMES magazine. The new influx of mail has TEMPORARILY solved our financial crisis but if TAP is to continue, I still need ideas, info, articles, and columns from you readers. Since some of you have made at least a token gesture, I have decided to do my part. Starting with this issue, TAP will begin publishing an issue a month. I will run a test period with the July and August issues. If the mail continues to bring in new subscribers, info, columns, and articles, I will then continue to publish monthly. If, however, YOU let me down (along with yourself and the other TAP readers), I will have NO other option other than to fold TAP! Our current office lease runs out on December 31, 1978, and while I love TAP, the fantastic amount of work on my part to publish an issue a month will make it VERY easy to lock up the TAP office for the last time on December 31.

I am bitching about getting some help for TAP the LAST time! TAP is NOT just a little four page info rag! It is an organization formed to collect, analyze, and disseminate data. YOU must supply the raw data. TAP will do all the rest.

© Youth Hot Line Reports, Inc. 1978 - Do not make checks out to Youth Hot Line Reports, PLEASE! Movement groups may reprint without permission with TAP's address given with all credits. Please send us a copy of reprinted work. **WARNING :** We will prosecute copyright violators.

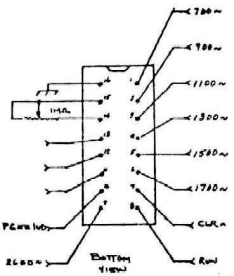
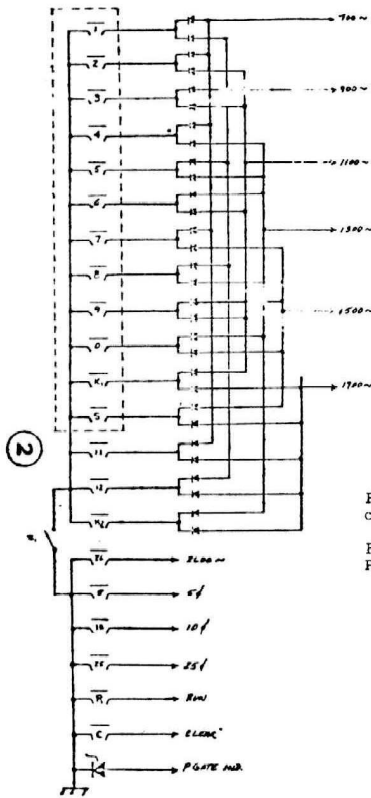

Figures 1, 2, and 3 make up the complete Auto-Combo Red/Blue Box.

Figure 4 is the Auto-Programmable Red Box.

FRONT PANEL

Figure 1

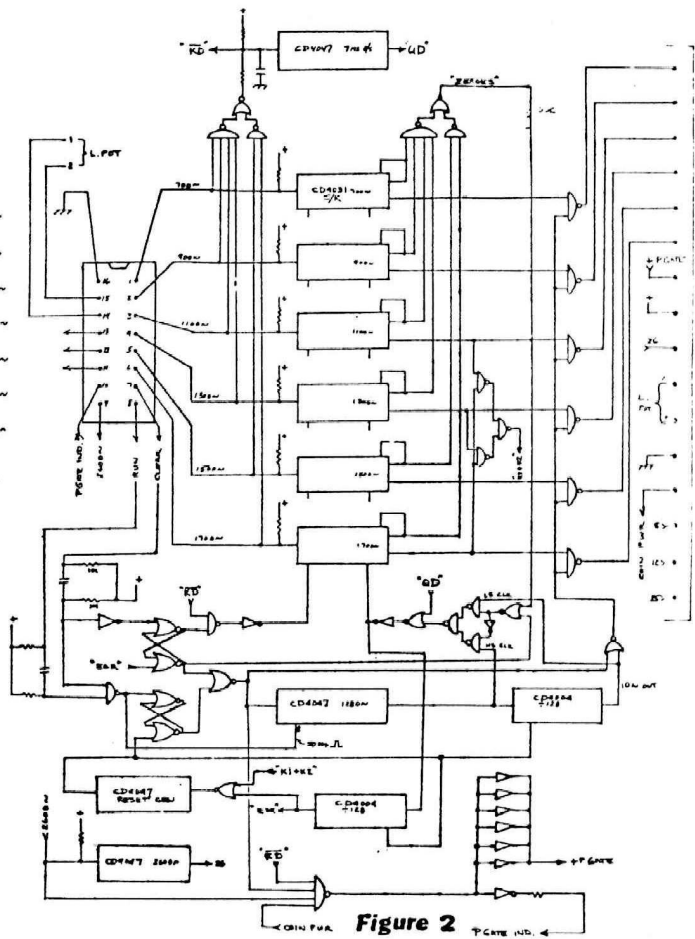

Figure 2

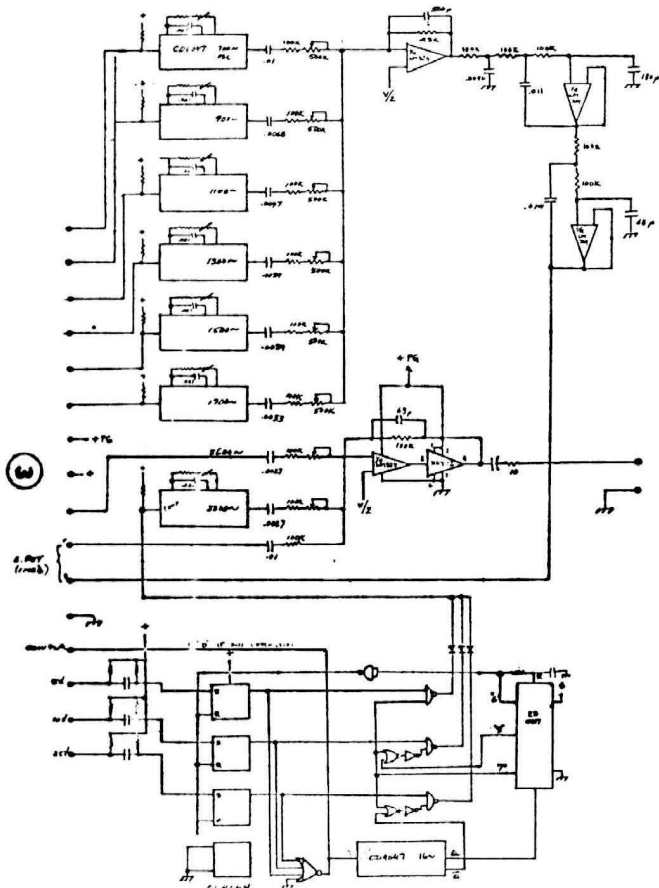

Figure 3

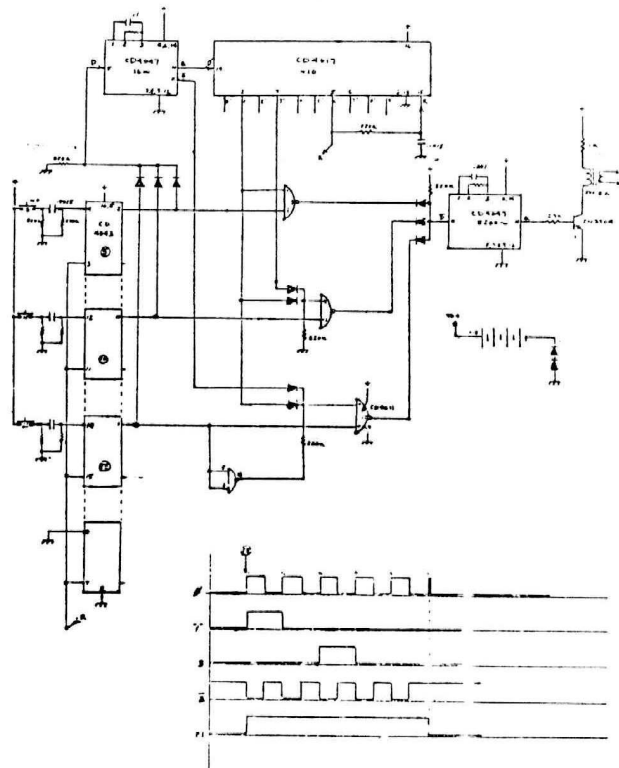

Figure 4

It's become increasingly obvious to all of us down at TAP that a lot of the phone phreaks out there are also computer hacks. That being the case I'd like to use this column, which will hopefully become a regular feature, to distribute information of interest to both phone phreaks and computer hacks. Some of the ideas and suggestions that have come up for this column are: applications of microprocessors to blue boxing, ways to break computer codes and penetration of computer security and defenses. I'd be interested in hearing any ideas or suggestions people have for this column. I'd especially like to hear from people who have used their personal computers to experiment with the phones. I'd also like to hear suggestions for converting Altairs, Apples, Cosmacs, Kims, and any other microcomputer for producing MF tones. Also, a letter was sent to TAP by someone who was converting a calculator into a blue box using a 6502 microprocessor. I'd like to hear what progress they've made. If anyone has ideas or designs for digital-to-analog converters for 8030, 6700, 6502 or 1302 based microcomputers I'd appreciate them or any hints or help you can give. Remember, this column, not to mention the rest of this rag; can only operate with suggestions from you, the readers.

Dear TAP,

It looks like I will be having quite a lot of work cut out for me in winning this latest bullshit hassle. I need as much support as I can get from everyone in the way of donations.

If I loose this case, it will mean some 200 or more people may get harrassed or arrested because this case is a test case.

People interested in helping out can mail contributions to: Phone Phreak Defense Phund, 164 West 21st Street, New York, N. Y. 10011.

Captain Crunch

Tongue-ried

NANCY, France (Reuters) - Motorist Louis Chachy, 34, who poked his tongue out at police manning a speed trap was fined 800 francs (\$166) for insulting behavior by a court here. Chachy denied the charge, saying he was only licking his lips because his mouth was dry.

Back Issues are 50¢ each.  
Subscriptions - 10 issues - US Bulk rate \$5.  
US First Class in plain sealed envelope \$7.  
Canada & Mexico First Class \$7.  
Foreign \$8.  
**IMPORTANT!** Include mailing label or Xerox copy when writing to TAP about your subscription.  
Electronics Courses - 50¢ each. A - DC Basics, B - AC Basics, C - Phone Basics, D - Amplifiers.  
TAP mugs - \$4.50.  
TAP T-shirts - \$4.50. Specify size and color: Small, Medium, Large, Extra Large. Black or red T-shirt with white TAP logo.  
TAP "Ma Bell is A Cheap Mother" T-shirts - \$4.50. Specify size and color: Medium, Large, Extra Large. Blue, tan, or yellow.  
Send **ONLY** check or money order (No Cash) to:  
TAP, Room 418, 152 West 42 Street, New York, N. Y. 10036  
This is a mail drop only.  
OFFICE: 1201 Broadway, Room 828, New York, N. Y. 10001  
HOURS: WEDNESDAY, 5 - 9 pm.

If any of you techno-electronic phone type people know anything about the new single chip MF encoder now available, please send the info to "The Magician" c/o TAP.

4

Readers have asked why I chose blue & yellow for the colors of issue #50. Since all our other issues are on white paper, I figured that if white, blue, & yellow were good enough for MA, they were good enough for TAP!

Published for informational purposes only by Youth Hot Line Reports, Inc.

Address all mail and checks to:

TAP, 152 W. 42 ST, ROOM 418, NY 10036

51

Bulk Rate  
U.S. POSTAGE  
PAID  
Permit No. 3  
Keasbey, N. J.



"I believe ethics should be a personal matter between a congressman and whoever he takes a bribe from."